

## Tool Specification

1. Part Number: YC-610R

2. Terminal: BPHD-001T-P0.5, BPA-001T-P0.5, BPAL-001T-P0.5, BPNI-001T-P0.5

### 3. Application

Crimp Position	AWG	Tensile	Strength N (kgf)	Strip Length mm
		BPHD-001T-P0.5 BPA-001T-P0.5 BPAL-001T-P0.5	BPNI-001T-P0.5	
A	UL1007 AWG 26	20(2.0) min.	19.6(2.0)min.	2.1
B	UL1007 AWG 24	30(3.1) min.	29.4(3.0)min.	2.1
B	UL1061 (AWG 22)	(40(4.1) min.)	(39.2(4.0)min.)	2.1

### Crimp Position

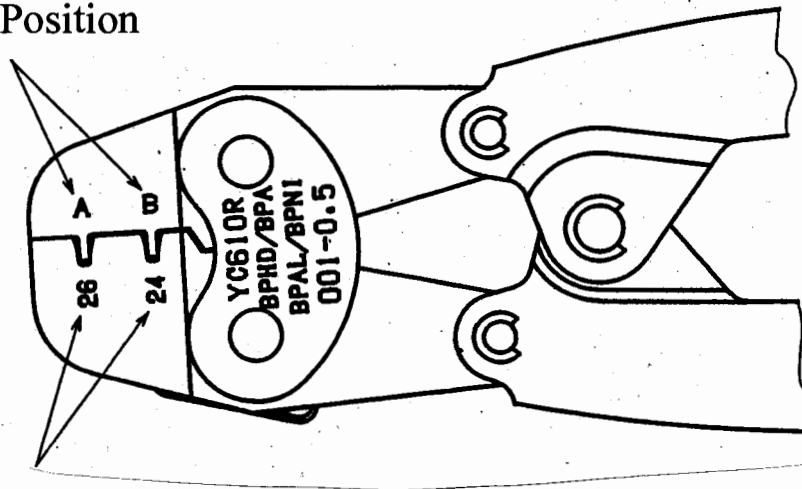

### AWG

- Check the crimp appearance and tensile strength prior to use.
- Select the appropriate crimp position based on the AWG that will be used.
- The wire in ( ) above could cause excessive crimping. Check the tensile strength and crimp appearance to confirm an acceptable crimp.
- The insulation barrel is set for type of wire listed and is not adjustable.