

THIS DRAWING IS UNPUBLISHED. RELEASED FOR PUBLICATION
 © COPYRIGHT BY TYCO ELECTRONICS CORPORATION. ALL RIGHTS RESERVED.

LOC	DIST	REVISIONS					
GP	00	P	LTR	DESCRIPTION	DATE	DWN	APVD
			A2	REV PER ECR-15-007399	13MAY2015	ML	SZ

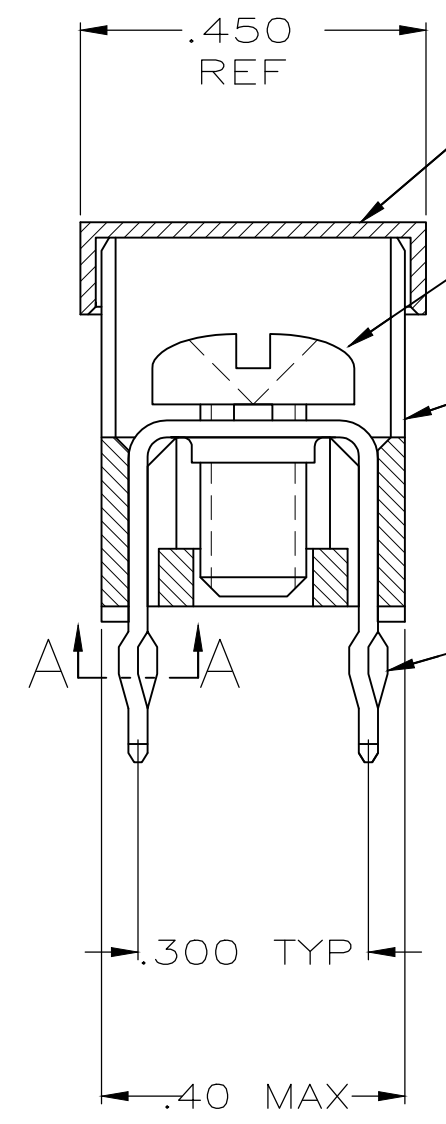

- COVER
 - SCREW, 993879-1
SUPPLIED UNASSEMBLED, SEE TABLE
 - HOUSING
 - TAP
- 1 TO PREVENT THREAD STRIPPING, SCREW TORQUE SHOULD NOT EXCEED 9 IN LBS.
 - 2 TAP HOLE IS 6-32UNC-2B, TWO MIN THREADS.
 - 3 PACKAGED BULK.
 - 4 HOUSING: THERMOPLASTIC
TAP: HIGH CONDUCTIVITY COPPER ALLOY
 - 5 TAP: .000050 REF MATTE TIN OVER .000050 MATTE NICKEL BASED PLATING.
 6. REFERENCE APPLICATION SPECIFICATION 114-11000 FOR DRILL HOLE SIZES AND FINISHES.

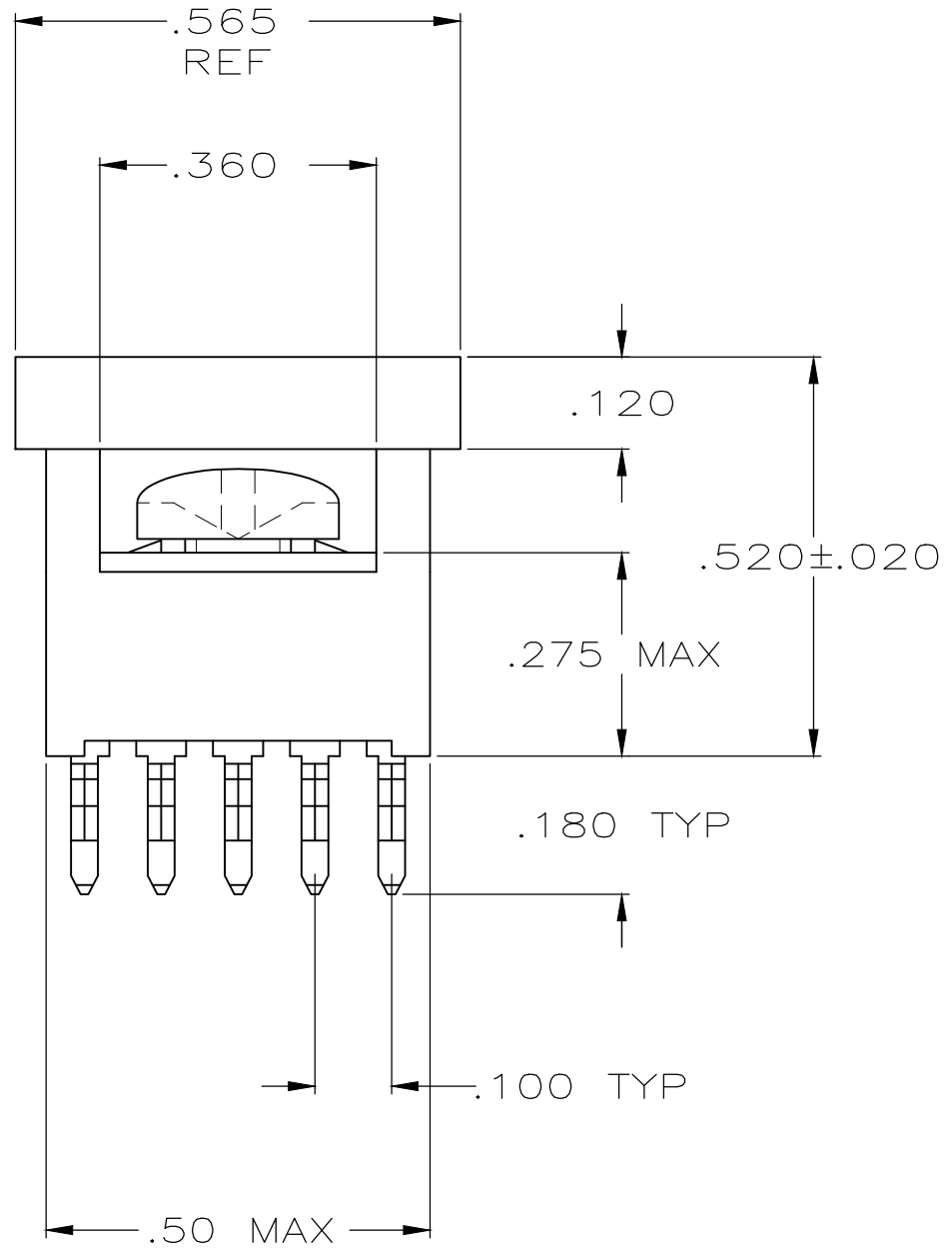

SECTION A-A
 SCALE 10:1
 10 PLACES

3	YES	YES	5055557-4
3	YES	NO	5055557-3
PACKAGING	HOUSING AND TAP ASSEMBLED	SCREW	PART NO.

THIS DRAWING IS A CONTROLLED DOCUMENT.		DWN J. ALCORTA - 05-04-05 DOCK5	Tyco Electronics Corporation Harrisburg, PA 17105-3608	
DIMENSIONS: INCHES		CHK A. FRANTUM 05-04-05		
TOLERANCES UNLESS OTHERWISE SPECIFIED:		APVD S. FLICKINGER 05-04-05	NAME POWER TAP CONNECTOR POWER DISTRIBUTION	
0 PLC ± -		PRODUCT SPEC 108-11030	SIZE A3	
1 PLC ± -		APPLICATION SPEC 114-11000	CAGE CODE 00779	DRAWING NO C-5055557
2 PLC ± -		WEIGHT -	RESTRICTED TO -	
3 PLC ± .010		CUSTOMER DRAWING		
4 PLC ± -		SCALE 4:1		
ANGLES ± -		SHEET 1 OF 1		
FINISH		REV A2		