

## Three-Wire Differential Sensor IC for Cam Application, Programmable Threshold

### FEATURES AND BENEFITS

- Allegro UC package with integrated EMC components provides robustness to most automotive EMC requirements
- Optimized robustness against magnetic offset variation
- Small signal lockout for immunity against vibration
- True zero-speed operation
- Air gap independent switch points
- Large operating air gaps achieved through use of gain adjust and offset adjust circuitry
- Customer-programmable switch points for mechanical tolerances compensation
- EEPROM programming for performance optimization and production traceability
- Differential sensing provides stray field immunity

### PACKAGE:



3-pin SIP (suffix UC)

*Not to scale*

### DESCRIPTION

The A16100 is a combined Hall-effect sensing integrated circuit and EMC protection circuit that provides a user-friendly, PCB-less solution for camshaft applications.

The A16100 incorporates a dual element Hall IC that switches in response to differential magnetic signals created by a ferromagnetic target. The IC contains a sophisticated compensating circuit designed to eliminate the detrimental effects of magnet and system offsets. Digital processing of the analog signal provides zero-speed performance independent of air gap and also dynamic adaptation of device performance to the typical operating conditions found in automotive applications (reduced vibration sensitivity). High-resolution peak detecting DACs are used to set the adaptive switching thresholds of the device. Hysteresis in the thresholds reduces the negative effects of any anomalies in the magnetic signal associated with the targets used in many automotive applications.

Customer-programmable thresholds allow fine adjustment of switch points for compensation of mechanical tolerances. Customer-programmable options through EEPROM allow for performance optimization to meet specific application requirements.

The A16100 is available in a lead (Pb) free 3-pin SIP package with a 100% matte-tin-plated leadframe.

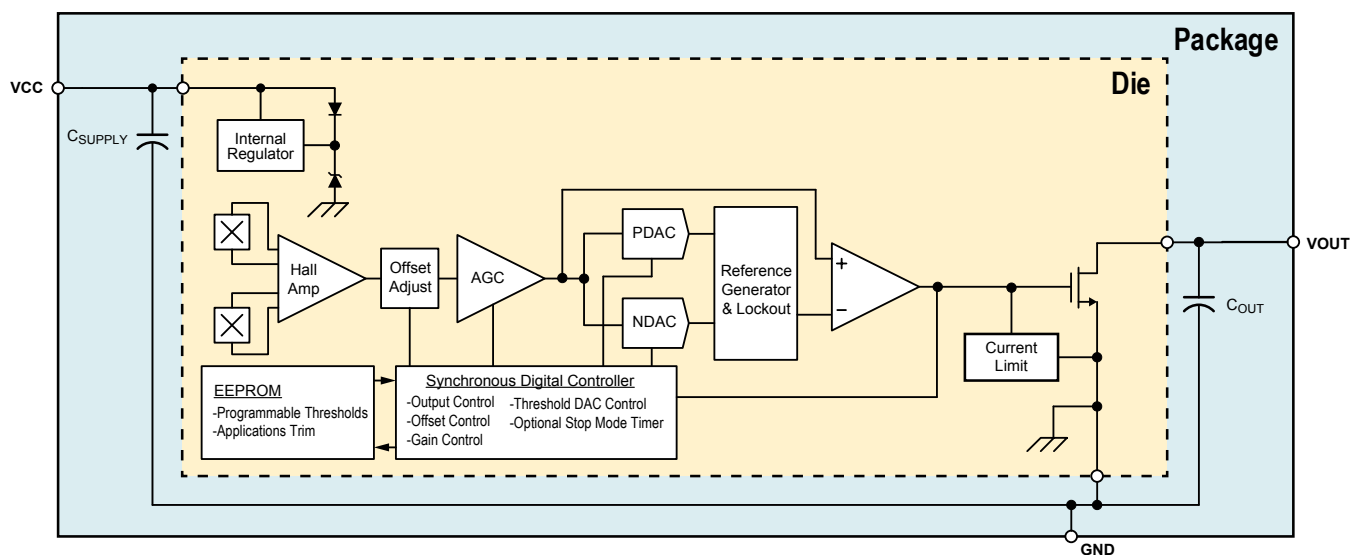

Figure 1: Functional Block Diagram

# A16100

# Three-Wire Differential Sensor IC for Cam Application, Programmable Threshold

## SELECTION GUIDE

Part Number	Package	Packing*
A16100PUCCTN	3-pin SIP	13-in. reel, 4000 pieces/reel



\*Contact Allegro™ for additional packing options.

## ABSOLUTE MAXIMUM RATINGS

Characteristic	Symbol	Notes	Rating	Unit
Supply Voltage	$V_{CC}$		27	V
Reverse Supply Voltage	$V_{RCC}$		-18	V
Output Voltage	$V_{OUT}$		27	V
Reverse Output Voltage	$V_{ROUT}$	$R_{PU} \geq 1000 \Omega$	-0.5	V
Output Current	$I_{OUT}$	Internal current limiting is intended to protect the device from output short circuits, but is not intended for continuous operation.	25	mA
Reverse Output Current	$I_{ROUT}$	$V_{OUT} > -0.5 \text{ V}$ , $T_A = 25^\circ\text{C}$	-50	mA
Operating Ambient Temperature	$T_A$	Range P	-40 to 160	$^\circ\text{C}$
Maximum Junction Temperature	$T_J(\text{max})$	Contact Allegro for extended junction temperature data	175	$^\circ\text{C}$
Storage Temperature	$T_{stg}$		-65 to 170	$^\circ\text{C}$

## INTERNAL DISCRETE COMPONENT RATINGS

Symbol	Characteristic	Rating	Unit
$C_{SUPPLY}$	Nominal Capacitance	220000	pF
$C_{OUT}$	Nominal Capacitance	4700	pF

### Pinout Diagram

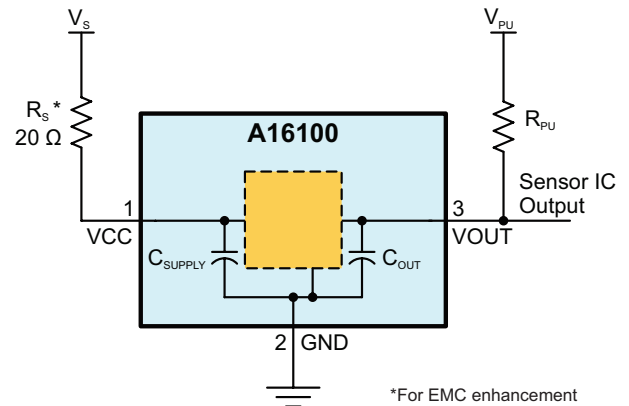
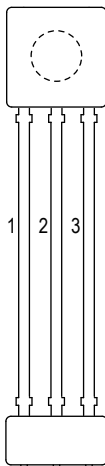

\*For EMC enhancement

Figure 2: Typical Application Circuit

### Terminal List

Number	Name	Function
1	VCC	Supply voltage
2	GND	Ground
3	VOUT	Open drain output

**OPERATING CHARACTERISTICS:** Valid at  $T_A = -40^\circ\text{C}$  to  $160^\circ\text{C}$  ( $T_J \leq T_{J(\text{MAX})}$ ) over operating air gap unless otherwise noted

Characteristics	Symbol	Test Conditions	Min.	Typ.	Max.	Unit
<b>ELECTRICAL CHARACTERISTICS</b>						
Supply Voltage	$V_{CC}$	Operating, $T_J < T_{J(\text{max})}$	4	5	24	V
Undervoltage Lockout	$V_{CCUV}$	$V_{CC}$ rising, 0 V $\rightarrow$ 5 V	–	3.9	–	V
		$V_{CC}$ falling 5 V $\rightarrow$ 0 V	–	3.6	–	V
Supply Zener Clamp Voltage	$V_{ZSUPPLY}$	$I_{CC} = I_{CC(\text{MAX})} + 3 \text{ mA}$	27	–	–	V
Reverse Supply Zener Voltage	$V_{RZSUPPLY}$	$I_{CC} = -3 \text{ mA}$ , $T_A = 25^\circ\text{C}$	–	–	-18	V
Supply Current	$I_{CC}$	$V_{CC} \leq 9 \text{ V}$	–	–	12	mA
		$V_{CC} > 9 \text{ V}$	–	–	13	mA
		$T_A = 160^\circ\text{C}$	–	–	11	mA
Reverse Supply Current	$I_{RCC}$	$V_{CC} = V_{RCC(\text{MAX})}$	–	–	-10	mA
<b>POWER-ON STATE CHARACTERISTICS</b>						
Power-On State	POS		–	high	–	–
Power-On Time	$t_{PO}$	speed < 200 rpm, $V_{CC} > V_{CC(\text{MIN})}$	–	–	1	ms
<b>OUTPUT STAGE</b>						
Output On Voltage	$V_{OUT(\text{SAT})}$	$I_{OUT} = 5 \text{ mA}$ , Output = On state ( $V_{OUT} = \text{Low}$ )	–	–	300	mV
		$I_{OUT} = 15 \text{ mA}$ , Output = On state ( $V_{OUT} = \text{Low}$ )	–	–	800	mV
Output Current Limit	$I_{OUT(\text{LIM})}$	Output = On State ( $V_{OUT} = \text{Low}$ )	30	–	80	mA
Output Leakage Current	$I_{OUT(\text{OFF})}$	$V_{OUT} = 24 \text{ V}$ , Output = Off state ( $V_{OUT} = \text{High}$ )	–	–	10	$\mu\text{A}$
Output Rise Time	$t_r$	Measured 10% to 90% of $V_{OUT}$ ; $R_{PU} = 1 \text{ k}\Omega$ , $V_{PU} = 5 \text{ V}$	–	10	–	$\mu\text{s}$
Output Fall Time	$t_f$	Measured 90% to 10% of $V_{OUT}$ ; $R_{PU} = 1 \text{ k}\Omega$ , $V_{PU} = 5 \text{ V}$	0.5	1.2	2.5	$\mu\text{s}$
Output Polarity		Programmable output polarity	–	–	–	–

**MAGNETIC CHARACTERISTICS:** Valid at  $T_A = -40^\circ\text{C}$  to  $160^\circ\text{C}$  ( $T_J \leq T_{J(\text{MAX})}$ ) over operating air gap unless otherwise noted

Characteristics	Symbol	Note	Min.	Typ.	Max.	Unit
<b>MAGNETIC CHARACTERISTICS</b>						
Allowable User Induced Differential Offset	$B_{\text{DIFFEXT}}$	User-induced differential offset	±200			G
Hall Spacing			2.2			mm
Operational Magnetic Range	$B_{\text{IN(FULL)}}$	Full in spec	60	–	1200	G
Bandwidth	$f_{3\text{dB}}$	Full bandwidth	16	20	–	kHz
Delay Time	$t_d$		–	17	–	$\mu\text{s}$

**FUNCTIONAL CHARACTERISTICS:** Valid at  $T_A = -40^\circ\text{C}$  to  $160^\circ\text{C}$  ( $T_J \leq T_{J(\text{MAX})}$ ) over operating air gap unless otherwise noted

Characteristics	Symbol	Note	Min.	Typ.	Max.	Unit
<b>FUNCTIONAL CHARACTERISTICS</b>						
Operational Air Gap Range	AG <sub>OP</sub>	For SmCo magnet	0.5	–	2.5 [1]	mm
Tooth to Tooth Jump	T2T		–	0.1	–	mm
			–	10	20	%
Runout	RO		–	0.1	–	mm
			–	10	20	%
Sudden Air Gap Change	AG <sub>SAG</sub>		–	0.45	–	mm
			–	45	–	%
Jitter	j	3 sigma @ 60 G <sub>pk-pk</sub> (+/-) on 45 mm diameter target	–	0.05	–	degrees
Die Placement Error	Err <sub>DIE</sub>		–	–	100	µm
Total Sensor Accuracy	Acc <sub>Sens</sub>	Total accuracy error including die position tolerance, not including air gap effect, speed effect, sensor misplacement. At room temperature.	–0.3	–	+0.3	degrees
Total Module Accuracy	Acc <sub>Mod</sub>	Including target runout, air gap effect, temperature	–1	–	+1	degrees
<b>VIBRATION IMMUNITY</b>						
Vibration Immunity	Err <sub>VIB</sub>	No flat line condition after vibration but functionality not guaranteed under vibration	T <sub>TARGET</sub>	–	–	degrees
<b>STOP MODE</b>						
Minimum Speed	f <sub>SPD</sub>	Zero speed capability	0	–	–	Hz
Stop Mode Timer Period (DAC Together EEPROM Option)	t <sub>SM</sub>	Timer interval to initiate Stop mode; no sensed magnetic edges	–	2	–	s
Missing/Additional Output Pulse		Missing/additional output edges during or after temperature drift inducing a magnetic drift up to 50 G	–	0 [2]	–	–
<b>SWITCH POINT CHARACTERISTICS</b>						
Update Method		Running mode	Bounded			–
Outward Update			Unlimited			%
Operating Point	B <sub>OP</sub> , B <sub>RP</sub>	Programmable	40	50	60	%
Threshold Step	B <sub>STEP</sub>	Step size %/LSB	–	2	–	%
Hysteresis	B <sub>HYS</sub>	Hidden hysteresis	–	16	–	%
<b>CALIBRATION</b>						
Initial Calibration	CAL <sub>I</sub>		–	3	13	teeth

[1] Maximum air gap based on Allegro 60X reference target. Maximum air gap can be defined with customer target mappings on request.

[2] In some specific high-temperature drift cases a single missing or additional output edges may be seen. PPM probabilities can be simulated with customer target mappings on request.

REFERENCE TARGET

Reference Target 60-0 (60 Tooth Target)

Characteristics	Symbol	Test Conditions	Typ.	Units	Symbol Key
Outside Diameter	$D_o$	Outside diameter of target	120	mm	
Face Width	F	Breadth of tooth, with respect to branded face	6	mm	
Circular Tooth Length	t	Length of tooth, with respect to branded face	3	deg.	
Circular Valley Width	$t_v$	Length of valley, with respect to branded face	3	deg.	
Tooth Whole Depth	$h_t$		3	mm	
Material		Low Carbon Steel	-	-	

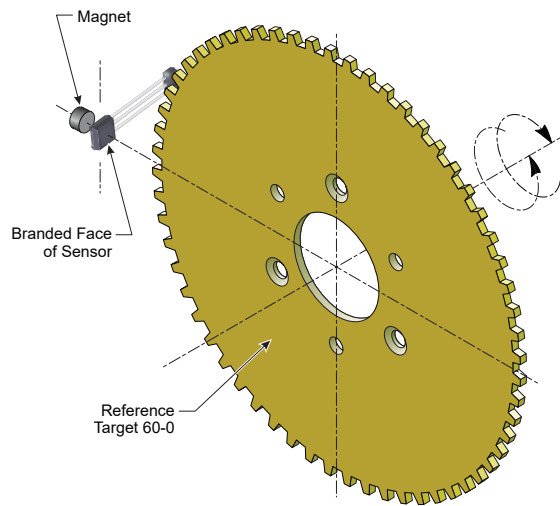

FUNCTIONAL DESCRIPTION

Operation

An operating device is capable of providing digital information that is representative of the mechanical features of a rotating gear. The waveform diagram in Figure 3 presents the automatic translation of the mechanical profile, through the magnetic profile that it induces, to the digital output signal of the A16100. No additional optimization is needed and minimal processing circuitry is required. This ease of use reduces design time and incremental assembly costs for most applications.

Determining Output Signal Polarity

In Figure 3, the top panel, labeled Mechanical Position, represents the mechanical features of the target gear and orientation to the device. The bottom panel, labeled Device Output Signal, displays the square waveform corresponding to the digital output signal that results from a rotating gear. That direction of rotation (of the gear side adjacent to the package face) is: perpendicular to the leads, across the face of the device, from the pin 1 side to the pin 3 side. This results in the IC output switching from low state to high state as the leading edge of a tooth (a rising mechanical edge, as detected by the IC) passes the package face. In this configuration, the device output switches to its high polarity when a tooth is the target feature nearest to the package. If the direction of rotation is reversed so that the gear rotates from the pin 3 side to the pin 1 side, then the output polarity inverts. That is, the output signal goes high when a falling edge is detected, and a valley is nearest to the package.

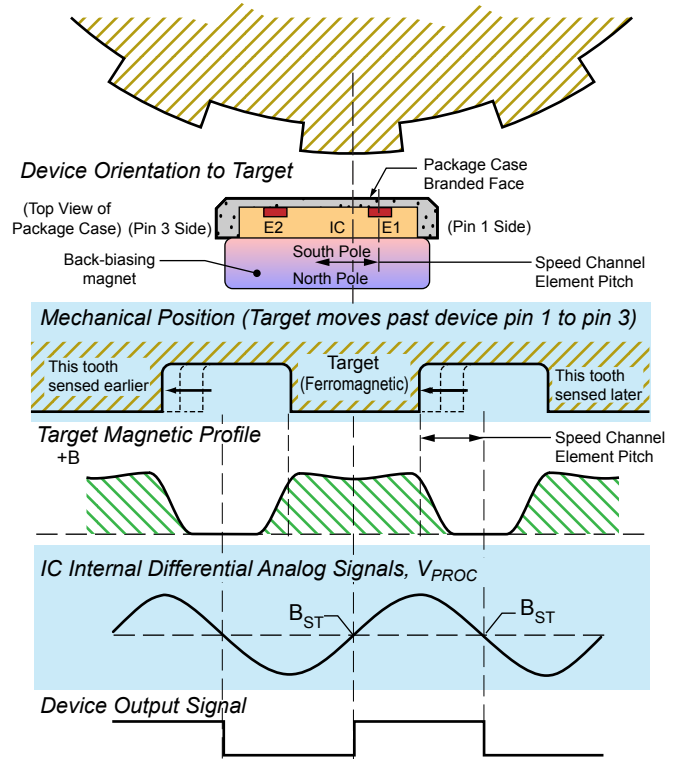

Figure 3: The magnetic profile reflects the geometry of the target, allowing the sensor IC to present an accurate digital output response. This example assumes thresholds set to 50%.

## Operating Modes

### CALIBRATION MODE

After the Power-On Time has elapsed, the Calibration period begins. While calibration is performed, the sensor IC begins to internally detect the magnetic profile of the target. The output becomes active after  $t_{OUT(init)}$ , at the first detection of a target switching feature generating a switch point.

The gain of the sensor IC is adjusted during the Calibration period, normalizing the internal signal amplitude for the air gap range of the device. This Automatic Gain Control (AGC) feature ensures that operational characteristics are isolated from the effects of installation air gap variation.

Automatic Offset Adjustment (AOA) is circuitry that compensates for the effects of chip, magnet, and installation offsets. (The capability of AOA is indicated by the Allowable User-Induced Magnetic Offset,  $B_{OFFSET}$ , in the Operating Characteristics table.) This circuitry works with the AGC during calibration to help center  $V_{PROC}$  in the dynamic range to allow for DAC acquisition of signal peaks.

Calibration mode also allows for the peak detecting DACs to properly acquire the magnetic signal, so that Running mode switch points can be accurately computed.

### RUNNING MODE

After calibration is complete, the device enters in Running mode, where the output accuracy is maximized.

Peak-tracking DAC algorithms allow tracking of signal drift resulting from temperature changes, as well as tracking of target variations, such as pole-to-pole variation and effective runout. Automatic Offset Adjustment remains active, allowing the IC to compensate for offsets induced by temperature variations over time.

### STOP MODE

In certain engine management applications, it is possible for large temperature changes to occur when the target is stationary. These temperature changes can affect the differential magnetic signals.

The Stop mode algorithm is engaged to compensate for such shifts in the processed signal that may be seen during stop and go conditions. Several observed edges of target rotation are required to leave Stop mode and return to Running mode.

## Device Technology

The A16100 true zero-speed device contains a self-calibrating Hall-effect IC that possesses two Hall elements, a temperature compensated amplifier, and offset cancellation circuitry. The IC also contains a voltage regulator that provides supply noise rejection over the operating voltage range. The Hall transducers and the electronics are integrated on the same silicon substrate using a proprietary BiCMOS process. Changes in temperature do not greatly affect this device due to the stable amplifier design and the offset rejection circuitry.

The single-chip differential Hall effect IC contains two Hall elements, spaced 2.2 mm apart, that measure the magnetic gradient created by a rotating ring magnet. The Hall elements measure the differential magnetic field and convert it to an analog voltage,  $V_{PROC}$ , that is then processed to provide a digital output signal.

## Programmable Switch Points

The Running mode switch points of the A16100 are established dynamically as a percentage of the amplitude of the internal signal,  $V_{PROC}$ . Two DACs track the peaks of  $V_{PROC}$  channel. The switching thresholds are established at fixed percentages of the values held in the DACs. The switching thresholds are customer programmable from 40 to 60% to allow accurate and consistent output switching and to compensate mechanical tolerances. Because the thresholds are established dynamically as a percentage of the peak-to-peak signal, the effect of a signal shift is minimized.

## Power Supply Protection

The device contains an on-chip regulator and can operate over a wide  $V_{CC}$  range. The device also includes integrated in-package EMC protection components providing robustness to most automotive EMC requirements without additional external passive components.

## Running Mode Lockout

The A16100 has a running mode lockout feature to prevent switching in response to small signals that are characteristic of vibration signals. The internal logic of the chip considers small-signal amplitudes below a certain level to be vibration. The output is held to the state prior to lockout until the amplitude of the signal returns to normal operational levels.

## Watchdog

The A16100 employs a watchdog circuit to prevent extended loss of output switching in case of moderate signal shift caused by sudden impulses or vibrations in the system. When the output stops switching, the watchdog will be fired, allowing the chip to self-reset and return to the initial calibration mode to regain output switching.

## Undervoltage Lockout

When the supply voltage falls below the undervoltage lockout voltage,  $V_{CC(min)}$ , the device enters Reset, where the output state returns to the Power-On State (POS) until sufficient  $V_{CC}$  is supplied. This lockout feature prevents false signals caused by undervoltage conditions from propagating to the output of the IC.

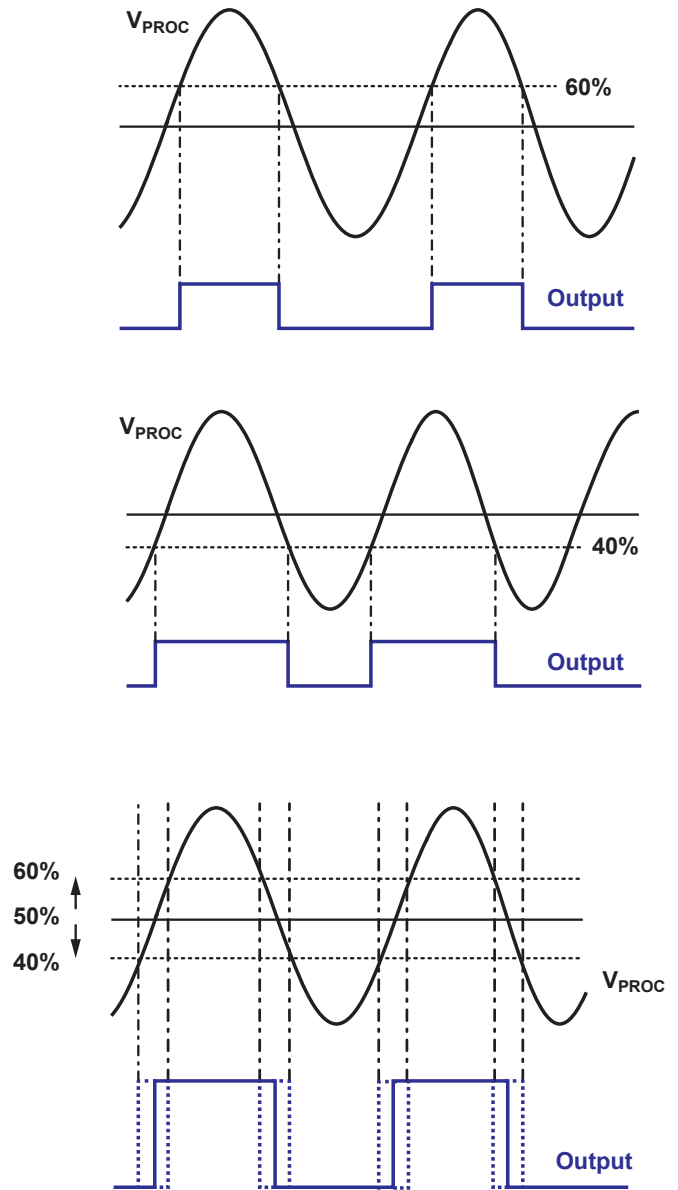

Figure 4: Programmable Switching Thresholds



## POWER DERATING

The device must be operated below the maximum junction temperature of the device,  $T_J(\max)$ . Under certain combinations of peak conditions, reliable operation may require derating supplied power or improving the heat dissipation properties of the application. This section presents a procedure for correlating factors affecting operating  $T_J$ . (Thermal data is also available on the Allegro MicroSystems website.)

The Package Thermal Resistance,  $R_{\theta JA}$ , is a figure of merit summarizing the ability of the application and the device to dissipate heat from the junction (die), through all paths to the ambient air. Its primary component is the Effective Thermal Conductivity,  $K$ , of the printed circuit board, including adjacent devices and traces. Radiation from the die through the device case,  $R_{\theta JC}$ , is a relatively small component of  $R_{\theta JA}$ . Ambient air temperature,  $T_A$ , and air motion are significant external factors, damped by overmolding.

The effect of varying power levels (Power Dissipation,  $P_D$ ), can be estimated. The following formulas represent the fundamental relationships used to estimate  $T_J$ , at  $P_D$ .

$$P_D = V_{IN} \times I_{IN} \quad (1)$$

$$\Delta T = P_D \times R_{\theta JA} \quad (2)$$

$$T_J = T_A + \Delta T \quad (3)$$

For example, given common conditions such as:  $T_A = 25^\circ\text{C}$ ,  $V_{CC} = 5\text{ V}$ ,  $I_{CC} = 8\text{ mA}$ , and  $R_{\theta JA} = 270^\circ\text{C/W}$ , then:

$$P_D = V_{CC} \times I_{CC} = 5\text{ V} \times 8\text{ mA} = 40\text{ mW}$$

$$\Delta T = P_D \times R_{\theta JA} = 40\text{ mW} \times 270^\circ\text{C/W} = 10.8^\circ\text{C}$$

$$T_J = T_A + \Delta T = 25^\circ\text{C} + 10.8^\circ\text{C} = 35.8^\circ\text{C}$$

A worst-case estimate,  $P_D(\max)$ , represents the maximum allowable power level ( $V_{CC}(\max)$ ,  $I_{CC}(\max)$ ), without exceeding  $T_J(\max)$ , at a selected  $R_{\theta JA}$  and  $T_A$ .

Example:

Reliability for  $V_{CC}$  at  $T_A = 160^\circ\text{C}$ , estimated values based on package UC, using single layer PCB.

Observe the worst-case ratings for the device, specifically:  $R_{\theta JA} = 270^\circ\text{C/W}$ ,  $T_J(\max) = 175^\circ\text{C}$ ,  $V_{CC(\text{absmax})} = 24\text{ V}$ , and  $I_{CC} = 11\text{ mA}$ .

Calculate the maximum allowable power level,  $P_D(\max)$ . First, invert equation 3:

$$\Delta T(\max) = T_J(\max) - T_A = 175^\circ\text{C} - 160^\circ\text{C} = 15^\circ\text{C}$$

This provides the allowable increase to  $T_J$  resulting from internal power dissipation. Then, invert equation 2:

$$P_D(\max) = \Delta T(\max) \div R_{\theta JA} = 15^\circ\text{C} \div 270^\circ\text{C/W} = 55.5\text{ mW}$$

Finally, invert equation 1 with respect to voltage:

$$V_{CC(\text{est})} = P_D(\max) \div I_{CC} = 55.5\text{ mW} \div 11\text{ mA} = 5.05\text{ V}$$

The result indicates that, at  $T_A$ , the application and device can dissipate adequate amounts of heat at voltages  $\leq V_{CC(\text{est})}$ .

Compare  $V_{CC(\text{est})}$  to  $V_{CC}(\max)$ . If  $V_{CC(\text{est})} \leq V_{CC}(\max)$ , then reliable operation between  $V_{CC(\text{est})}$  and  $V_{CC}(\max)$  requires enhanced  $R_{\theta JA}$ . If  $V_{CC(\text{est})} \geq V_{CC}(\max)$ , then operation between  $V_{CC(\text{est})}$  and  $V_{CC}(\max)$  is reliable under these conditions.

## THERMAL CHARACTERISTICS: May require derating at maximum conditions

Characteristic	Symbol	Test Conditions*	Value	Unit
Package Thermal Resistance	$R_{\theta JA}$	1-layer PCB with copper limited to solder pads	270	$^\circ\text{C/W}$

\*Additional thermal information available on the Allegro website.

## Package UC, 3-Pin SIP

### For Reference Only – Not for Tooling Use

(Reference DWG-0000409, Rev. 3)  
 Dimensions in millimeters – NOT TO SCALE  
 Dimensions exclusive of mold flash, gate burrs, and dambar protrusions  
 Exact case and lead configuration at supplier discretion within limits shown

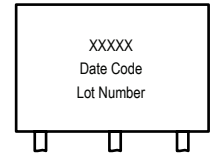
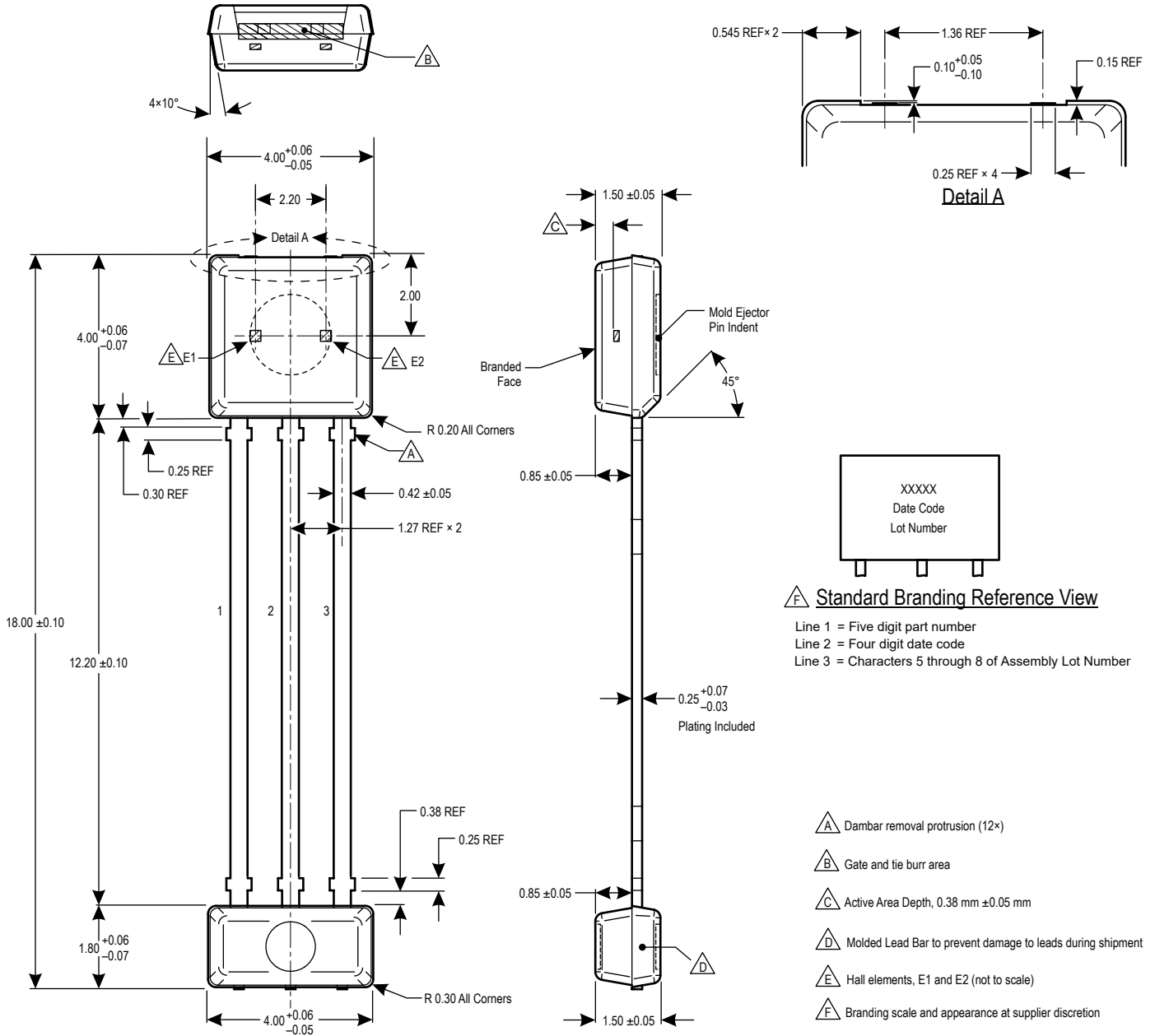

**F Standard Branding Reference View**  
 Line 1 = Five digit part number  
 Line 2 = Four digit date code  
 Line 3 = Characters 5 through 8 of Assembly Lot Number

- A** Dambar removal protrusion (12x)
- B** Gate and tie burr area
- C** Active Area Depth,  $0.38 \pm 0.05$  mm
- D** Molded Lead Bar to prevent damage to leads during shipment
- E** Hall elements, E1 and E2 (not to scale)
- F** Branding scale and appearance at supplier discretion

**Revision History**

Number	Date	Description
–	May 9, 2018	Initial release
1	May 23, 2018	Corrected part number in selection guide
2	May 30, 2019	Minor editorial updates

Copyright 2019, Allegro MicroSystems.

Allegro MicroSystems reserves the right to make, from time to time, such departures from the detail specifications as may be required to permit improvements in the performance, reliability, or manufacturability of its products. Before placing an order, the user is cautioned to verify that the information being relied upon is current.

Allegro's products are not to be used in any devices or systems, including but not limited to life support devices or systems, in which a failure of Allegro's product can reasonably be expected to cause bodily harm.

The information included herein is believed to be accurate and reliable. However, Allegro MicroSystems assumes no responsibility for its use; nor for any infringement of patents or other rights of third parties which may result from its use.

Copies of this document are considered uncontrolled documents.

For the latest version of this document, visit our website:

[www.allegromicro.com](http://www.allegromicro.com)