

THIS DRAWING IS UNPUBLISHED. RELEASED FOR PUBLICATION
 © COPYRIGHT - TE Connectivity ALL RIGHTS RESERVED.

REVISIONS				
P	LTR	DESCRIPTION	DATE	APVD
M		REV PER ECO 17-014855	10-11-17	CT PR

ASSEMBLED VIEW

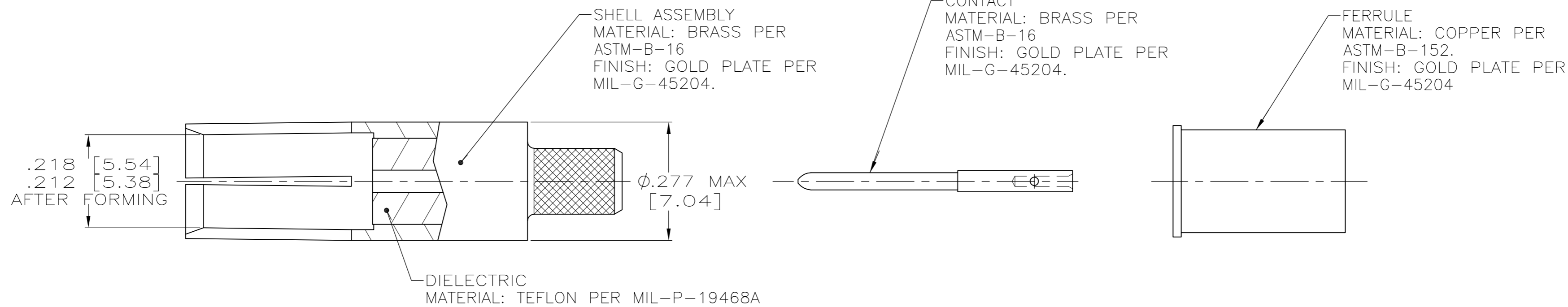
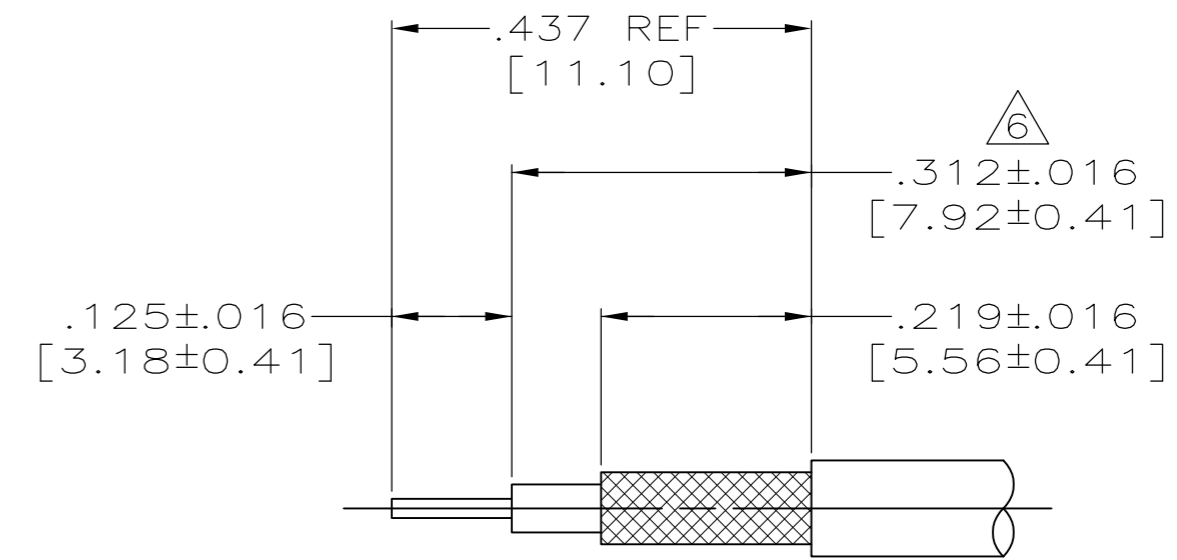
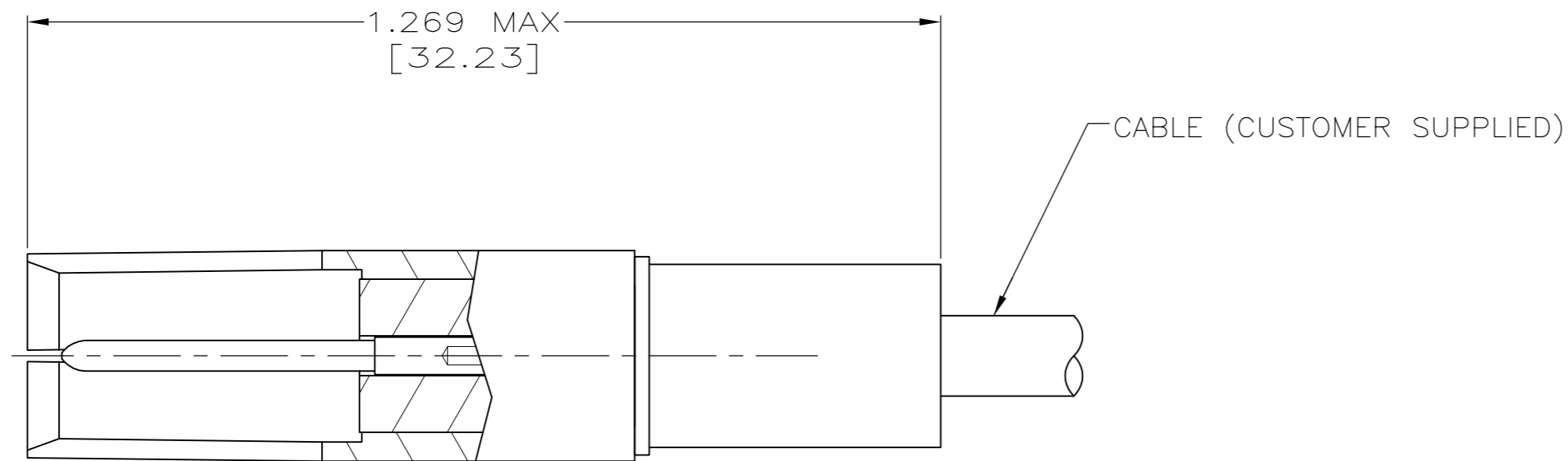

- FOR USE WITH RG-58 C/U & 141 A/U COAX CABLE.
- FERRULE CRIMPING TOOL: AMP TOOL #220066-1 OR 220066-2 CRIMP B.
- CONTACT CRIMPING TOOL:M22520/2-01 OR AMP TOOL NUMBER 601966-1, SETTING NUMBER 5. DANIELS POSITIONER PART NO. K345 OR AMP TOOL NO. 1-601966-6.
- SEE I.S.2348.
- DANIELS MANUFACTURING CORP
2266 FRANKLIN ROAD
BLOOMFIELD HILLS, MI 48013

△ OUTER JACKET OF CABLE MUST BE TRIMMED TO ALLOW PROPER INTER-PIN CONTACT LOCATION AFTER FERRULE CRIMP OPERATION.

- PARTS SHIPPED UNASSEMBLED AND CABLE IS SUPPLIED BY CUSTOMER.

225791-1

225791-1
PART NO.

THIS DRAWING IS A CONTROLLED DOCUMENT.		DWN C.C.THOMAS 2-1-95		
DIMENSIONS: INCHES		CHK J.DUNBAR 2-2-95		
TOLERANCES UNLESS OTHERWISE SPECIFIED:		APVD J.DUNBAR 2-2-95	NAME CONNECTOR,COAXIAL,RF SOCKET SIZE 5, ARINC	
0 PLC ± - 1 PLC ± - 2 PLC ± - 3 PLC ± - 4 PLC ± - ANGLES ± -		PRODUCT SPEC -	APPLICATION SPEC -	
MATERIAL SEE CALLOUTS		FINISH -	WEIGHT 0	RESTRICTED TO -
		CUSTOMER DRAWING	SCALE 5:1	SHEET 1 of 1
		SIZE A2	CAGE CODE 00779	DRAWING NO C=225791-1
				REV M