

RECOMMENDED PCB LAYOUT AND KEEP-OUT ZONE

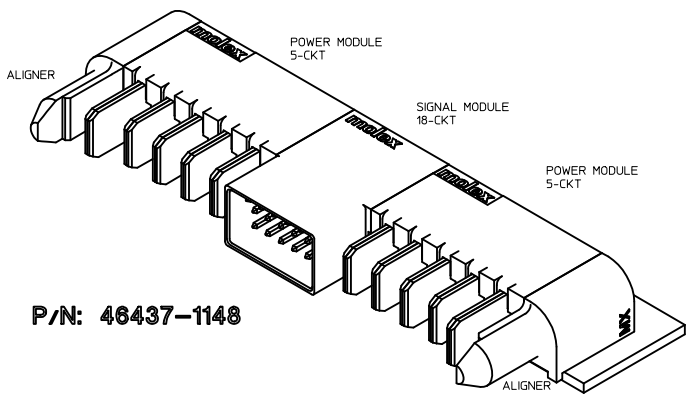
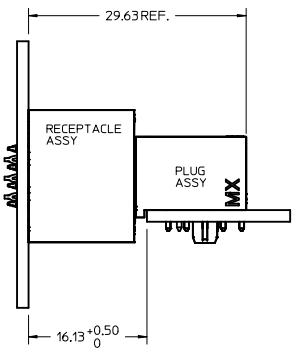
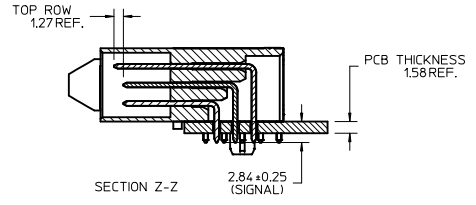
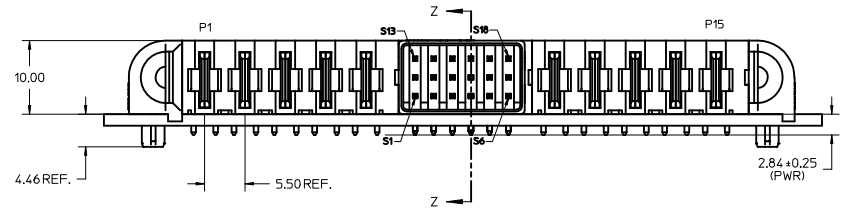

P/N: 46437-1148

NOTES:

- MATERIAL:
  - HOUSINGS: LCP UL94 V-0, COLOR: BLACK.
  - TERMINALS: COPPER ALLOY.
  - PLATING: 0.000127 NICKEL OVERALL WITH 0.00254 SELECTIVE MATTE TIN ON TAILS AND 0.000762 SELECTIVE GOLD ON CONTACT AREA.
- PACKAGING ASSEMBLIES TO BE TRAY PACKED, STD. QUANTITY: TBD.
- PC BOARD REQUIRES SOLDER THRU HOLES. REFER TO PS-46436-100 FOR DETAILS.
- PRODUCT SPEC: PS-46436-100.
- APPLICATION SPEC: AS-46436-100.
- SEE PRODUCT SPEC. FOR RoHS REQUIREMENTS.
- ASSEMBLY MATES WITH MOLEX RECEPTACLE ASSEMBLY, P/N 46562-1148.

|  |  |                                       |   |               |              |                        |
|--|--|---------------------------------------|---|---------------|--------------|------------------------|
| FINAL RELEASE<br>IEC NO: UCP2011-2459<br>DRWN: JSCHAEFER 2011/02/16<br>CHKD:<br>APPR: APATEL 2011/03/03<br>REV DESCRIPTION | QUALITY SYMBOLS                                      | GENERAL TOLERANCES (UNLESS SPECIFIED) | DIMENSION STYLE   | SCALE         | DESIGN UNITS | THIRD ANGLE PROJECTION |
|  |  | mm INCH                               | MM ONLY   | 3:1           | METRIC       |                        |
|  |  | 4 PLACES ± --- ± ---                  | DRAWN BY DATE   | TITLE         |              |                        |
|  |  | 3 PLACES ± --- ± ---                  | CHKD BY DATE  | RA PLUG ASSY  |              |                        |
|  | 2 PLACES ± 0.25 ± ---                                | APPROVED BY DATE                      | SP-18S-5P   |               |              |                        |
|  | 1 PLACE ± 0.25 ± ---                                 | APATEL 2011/03/03                     | TEN60 POWER FAMILY  |               |              |                        |
|  | ANGULAR ± 1/2°                                       |                                       | MOLEX INCORPORATED  |               |              |                        |
|  | DRAFT WHERE APPLICABLE MUST REMAIN WITHIN DIMENSIONS |                                       | MATERIAL NO.  | DOCUMENT NO.  | SHEET NO.    |                        |
|  |  |                                       | 46437-1148  | SD-46437-1148 | 1 OF 1       |                        |
|  |  |                                       | THIS DRAWING CONTAINS INFORMATION THAT IS PROPRIETARY TO MOLEX INCORPORATED AND SHOULD NOT BE USED WITHOUT WRITTEN PERMISSION |               |              |                        |

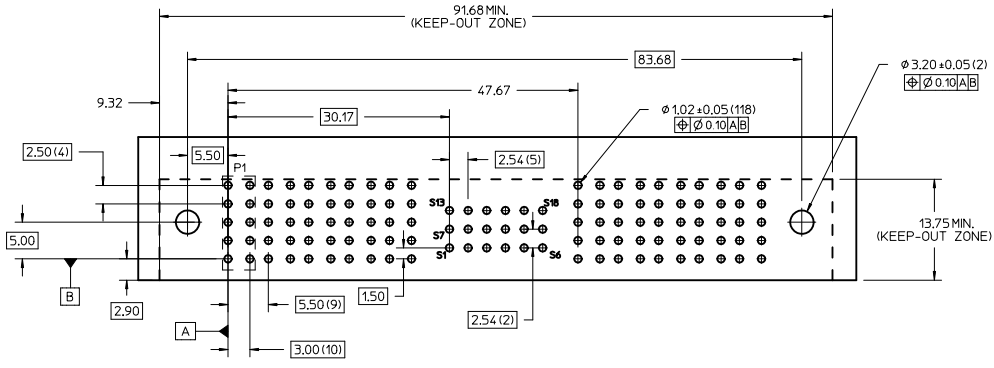
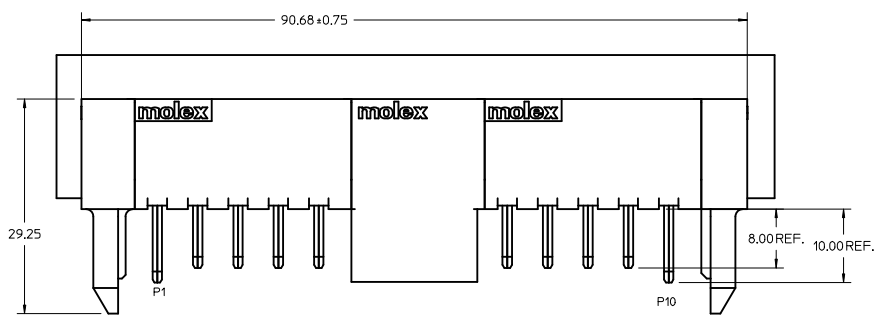

RECOMMENDED PCB LAYOUT AND KEEP-OUT ZONE

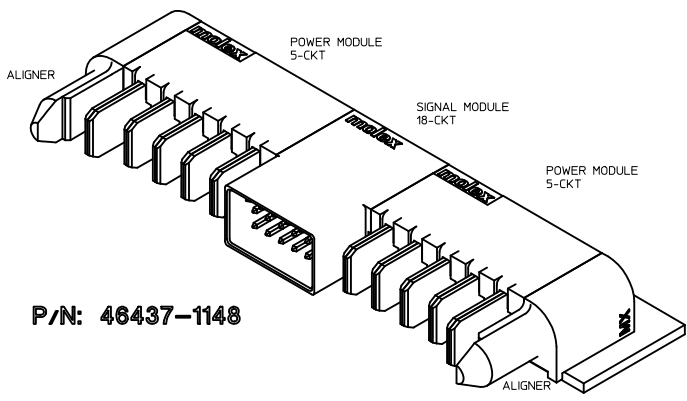
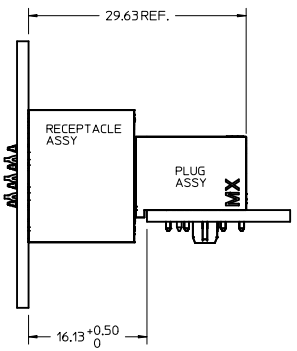
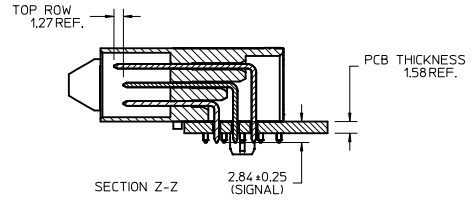
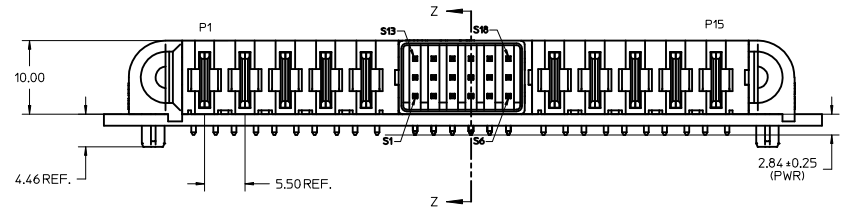

- NOTES:
- MATERIAL:
    - HOUSINGS: LCP UL94 V-0, COLOR: BLACK.
    - TERMINALS: COPPER ALLOY.
    - PLATING: 0.000127 NICKEL OVERALL WITH 0.00254 SELECTIVE MATTE TIN ON TAILS AND 0.000762 SELECTIVE GOLD ON CONTACT AREA.
  - PACKAGING ASSEMBLIES TO BE TRAY PACKED, STD. QUANTITY: TBD.
  - PC BOARD REQUIRES SOLDER THRU HOLES. REFER TO PS-46436-100 FOR DETAILS.
  - PRODUCT SPEC: PS-46436-100.
  - APPLICATION SPEC: AS-46436-100.
  - SEE PRODUCT SPEC. FOR RoHS REQUIREMENTS.
  - ASSEMBLY MATES WITH MOLEX RECEPTACLE ASSEMBLY, P/N 46562-1148.

|  |                       |  |                                       |                               |   |                        |
|--|-----------------------|--|---------------------------------------|-------------------------------|---|------------------------|
| FINAL RELEASE<br>IEC NO: UCP2011-2459<br>DRWN: JSCHAEFER 2011/02/16<br>CHKD:<br>APPR: APATEL 2011/03/03<br>REV DESCRIPTION | QUALITY SYMBOLS       | GENERAL TOLERANCES (UNLESS SPECIFIED)                | DIMENSION STYLE<br>MM ONLY            | SCALE<br>3:1                  | DESIGN UNITS<br>METRIC  | THIRD ANGLE PROJECTION |
|  |                       | mm INCH  | DRAWN BY DATE<br>BKOSTIC 2010/06/02   | TITLE<br>RA PLUG ASSY         |   |                        |
|  |                       | 4 PLACES ± --- ± ---                                 | CHECKED BY DATE<br>BKOSTIC 2010/06/02 | SP-18S-5P                     |   |                        |
|  |                       | 3 PLACES ± --- ± ---                                 | APPROVED BY DATE<br>APATEL 2011/03/03 | TEN60 POWER FAMILY            |   |                        |
|  | 2 PLACES ± 0.25 ± --- |  | MATERIAL NO.<br>46437-1148            | DOCUMENT NO.<br>SD-46437-1148 | MOLEX INCORPORATED  |                        |
|  | 1 PLACE ± 0.25 ± ---  |  | SHEET NO.<br>1 OF 1                   |                               | THIS DRAWING CONTAINS INFORMATION THAT IS PROPRIETARY TO MOLEX INCORPORATED AND SHOULD NOT BE USED WITHOUT WRITTEN PERMISSION |                        |
|  | ANGULAR ± 1/2°        | DRAFT WHERE APPLICABLE MUST REMAIN WITHIN DIMENSIONS |                                       |                               |   |                        |