

S20 Actual Size

## Miniature Linear Motion Series · S20

Actuonix Motion Devices unique line of Miniature Linear Actuators enables a new generation of motion-enabled product designs, with capabilities that have never before been combined in a device of this size. These linear stepper actuators are a superior alternative to designing your own push/pull mechanisms.

The S20 actuators are complete, self-contained linear motion devices. Several stroke length options allow these to fit a wide variety of applications.

### S20 Specifications

Stroke Option	15mm	30mm	50mm	100mm
Mass	62g	64g	70g	84g
Closed Length hole to hole	89.8mm	104.8mm	124.8mm	174.8mm
Maximum Side Load	≈ 0.10 * Maximum Force			
Step Size	0.01mm			
Backdrive Force	40N ( <i>no power applied</i> )		60N ( <i>power applied</i> )	
Temperature Rise	80°C Max			
Input Voltage	0-4.2 VDC			
Max Current (per phase)	0.60A			
Operating Temperature	-10°C to +40°C			
Audible Noise	< 40 dB @ 45cm low noise settings			
Ingress Protection	IP-54			
Mechanical Backlash	0.1mm			
Inductance (per phase)	2.1mH@1khz			
Resistance (per phase)	7ohm			
Maximum Duty Cycle	100%			

The brushless stepper design makes the S20 our highest precision and longest life actuator.

### Applications

- Robotics
- Optics
- Diagnostic Equipment
- Industrial Automation

All data on this sheet is provided for information purposes only and is subject to change. Purchase and use of Actuonix Actuators is subject to our terms and conditions as posted here:  
<http://www.Actuonix.com/terms.asp>

### Basis of Operation

The S20 is designed to push or pull a load axially along its full stroke length. The speed of travel is determined by the step frequency, and maximum force by the current applied. When power is removed the actuator will hold its position, unless the applied load exceeds the back drive force. Actuators should be tested in each specific application to determine their effective life under those loading conditions and environment.

### Ordering

Small quantity orders can be placed directly online at [www.Actuonix.com](http://www.Actuonix.com). Purchase orders, volume quotes, and custom order requests can be sent to [sales@actuonix.com](mailto:sales@actuonix.com). MOQ for custom strokes, cables or connectors is typically 500pcs. Each actuator ships with two mounting brackets and #8-32 mounting hardware. The cable length is approximately 300mm with actuator mating connector and bared leads. The thread in the end of the round aluminum shaft is M8x1.25.

## Model Selection

S20 options are identified according to the following model numbering scheme:

### S20-SS-MM-C

Feature	Options
<b>SS:</b> Stroke	<b>15, 30, 50, 100</b> (mm)
<b>MM:</b> Motor	<b>38</b> (mm)
<b>C:</b> Controller	<b>B</b> None - Motor Wires Only

## S20 Controller Options

### Option B – None - Motor Wires Only

#### WIRING:

A1 - BLUE – Motor Coil A +  
 A2 - RED – Motor Coil A -  
 B1 - GREEN – Motor Coil B +  
 B2 - BLACK – Motor Coil B -

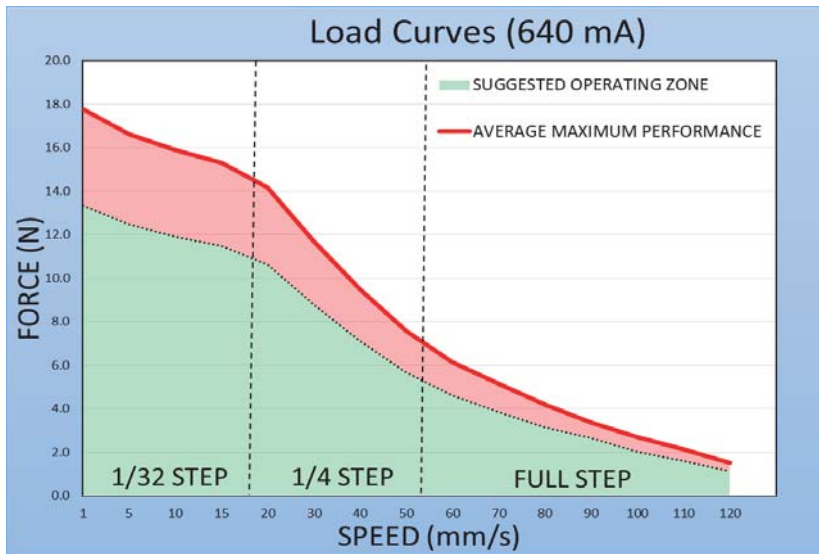
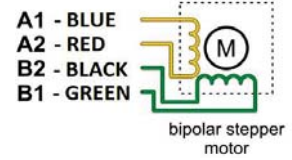

**WARNING:** As the applied force approaches the maximum force there is greater risk for missed steps to occur.

## Driver Selection and Settings

The S20 can be driven by most standard 4 wire stepper drivers. Actuonix offers the Tic T825 USB Multi-Interface Stepper Motor Controller. This driver is easily adjustable so that you can determine the best settings for your application. The controller supports six control interfaces: USB, TTL serial, I<sup>2</sup>C, analog voltage, quadrature encoder, and RC. Refer to the Pololu Tic T825 Datasheet for further driver specific details.

For reliable operation it is suggested that the applied force fall between 50%-75% of maximum force for a given speed.

For quiet and smooth operation at low speeds we recommend a micro step setting. At medium speeds the full step setting (1), will provide an improvement in maximum load, while still minimizing audible noise. At high speeds we recommend Full Step with limited acceleration and deceleration (Ramp the frequency of your step control signal). Without adequate ramping, the actuator will not move. Note: Ramped Micro step settings can also be used at higher speeds, however this will reduce the maximum force.

To save power on light load applications, you can reduce the constant current setting below the rated value. For higher loads you can increase current beyond the rated value, however your duty cycle may need to be reduced to keep the motor within the acceptable temperature range. Note: Exceeding datasheet rated values can reduce motor life, and is not covered by our warranty.

Microstepping can be used to increase resolution, however there will be some non-linearity between microsteps, and reduced holding force.

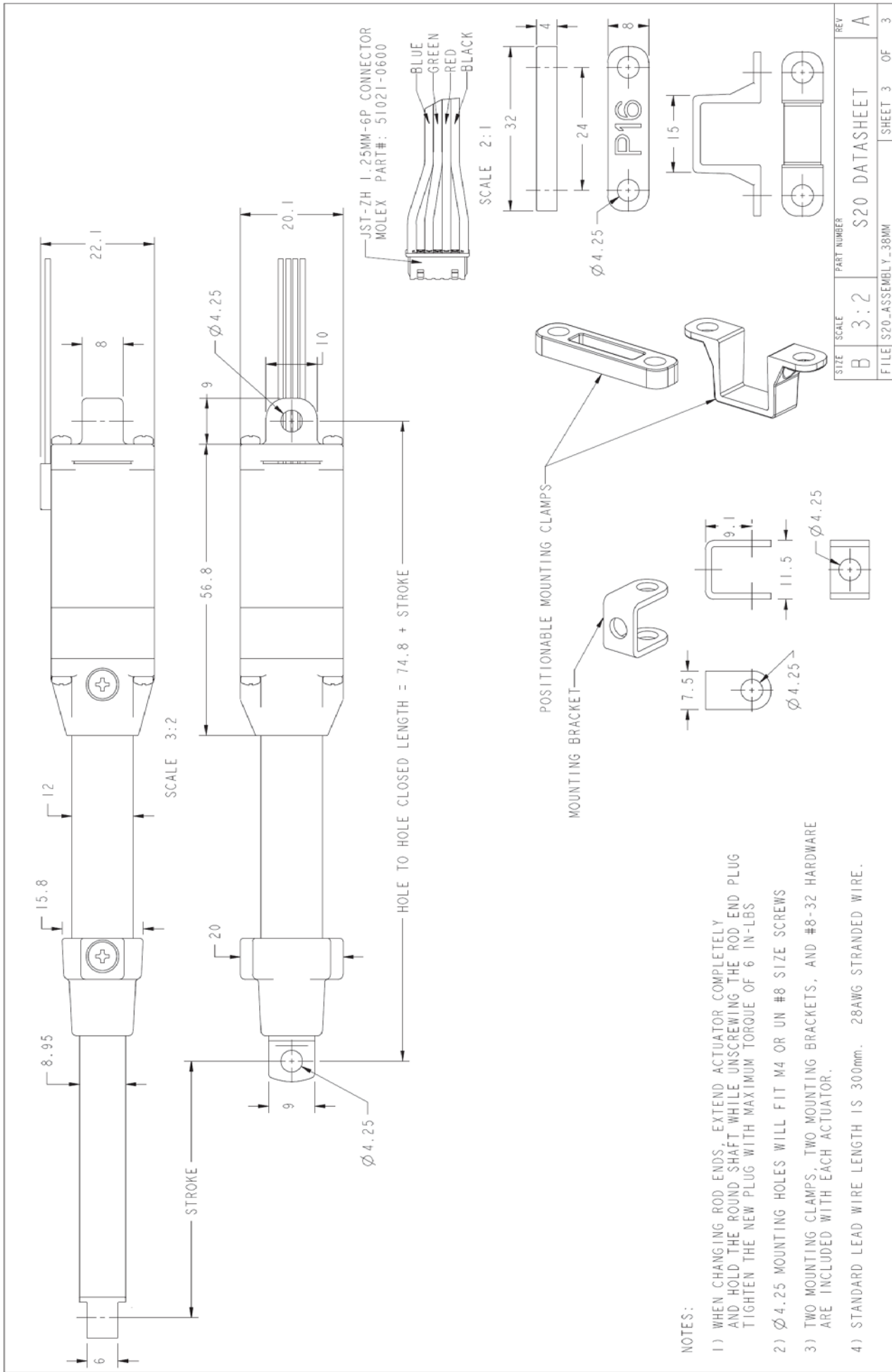

NOTES:

- 1) WHEN CHANGING ROD ENDS, EXTEND ACTUATOR COMPLETELY AND HOLD THE ROUND SHAFT WHILE UNSCREWING THE ROD END PLUG. TIGHTEN THE NEW PLUG WITH MAXIMUM TORQUE OF 6 IN-LBS
- 2) Ø 4.25 MOUNTING HOLES WILL FIT M4 OR UN #8 SIZE SCREWS
- 3) TWO MOUNTING CLAMPS, TWO MOUNTING BRACKETS, AND #8-32 HARDWARE ARE INCLUDED WITH EACH ACTUATOR.
- 4) STANDARD LEAD WIRE LENGTH IS 300mm. 28AWG STRANDED WIRE.



Actuonix Motion Devices Inc. 1 (206) 347-9684 Phone  
 Unit 201-1753 Sean Heights 1 (888) 225-9198 Toll Free  
 Saanichton, BC Canada 1 (206) 347-9684 Fax  
 V8M 0B3

sales@actuonix.com  
 www.actuonix.com

All data on this sheet is provided for information purposes only and is subject to change. Purchase and use of Actuonix Actuators is subject to our terms and conditions as posted here: <http://www.actuonix.com/terms.asp>