

DO NOT SCALE FROM THIS PRINT

Pb THIS PRODUCT MANUFACTURED WITH LEAD-FREE PROCESSING

DESIGNED & DIMENSIONED IN MILLIMETERS [INCHES]

MCX-J-C-X-ST-CA1

GENDER
-J: JACK

TYPE
-C: CABLE

TERMINATION
-CA1: CABLE (RG174 OR RG316)

ORIENTATION
-ST: STRAIGHT

PLATING SPECIFICATION
-H: 30µ" GOLD CENTER CONTACT, 3µ" GOLD OUTER CONTACT (SEE TABLE 1)

TABLE 1		
ITEM	COMPONENT	-H
1	FERRULE	MCX-FER-001-F
2	PIN	MCX-SKT-001-H
3	SUB ASSEMBLY	SUB-MCX-J-C-F-ST-CA1

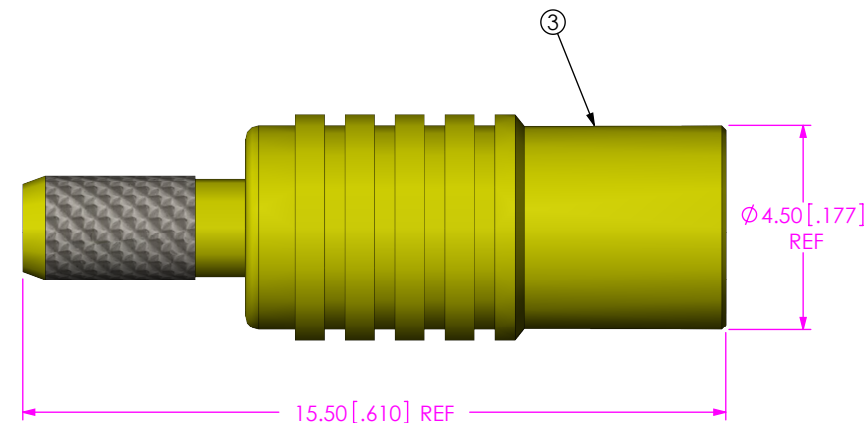
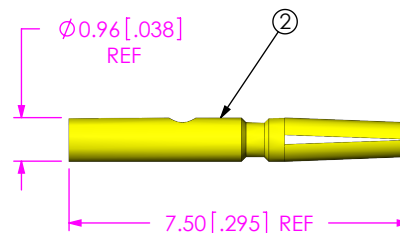
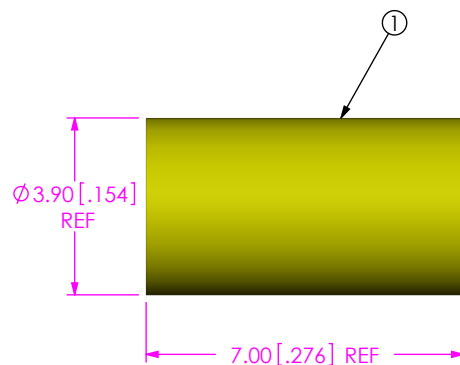

NOTES:

- ① REPRESENTS A CRITICAL DIMENSION.
- CENTER CONTACT PUSHOUT FORCE: 10 N [2.25 LB] MIN.
- NOTE DELETED.
- NOTE DELETED.
- PRODUCT TO BE PACKAGED PER PACKAGING STANDARD CO-RF-WI-3040-M.
- NOTE DELETED.
- NOTE DELETED.
- NOTE DELETED.

F:\DWG\MISC\MKTG\MCX-J-C-X-ST-CA1-MKT.SLDDRW

<p>UNLESS OTHERWISE SPECIFIED, DIMENSIONS ARE IN MILLIMETERS [INCHES]. TOLERANCES ARE: DECIMALS ANGLES .X: ±0.3 [.01] 5° .XX: ±0.13 [.005] .XXX: ±0.051 [.0020]</p>	<p>PROPRIETARY NOTE THIS DOCUMENT CONTAINS INFORMATION CONFIDENTIAL AND PROPRIETARY TO SAMTEC, INC. AND SHALL NOT BE REPRODUCED OR TRANSFERRED TO OTHER DOCUMENTS OR DISCLOSED TO OTHERS OR USED FOR ANY PURPOSE OTHER THAN THAT WHICH IT WAS OBTAINED WITHOUT THE EXPRESSED WRITTEN CONSENT OF SAMTEC, INC.</p>	 520 PARK EAST BLVD, NEW ALBANY, IN 47150 PHONE: 812-944-6733 FAX: 812-948-5047 e-Mail: info@SAMTEC.com code: 55322
<p>MATERIAL: DO NOT SCALE DRAWING SHEET SCALE: 6:1 SHELL, FERRULE: BRASS CONTACT: COPPER ALLOY DIELECTRIC: PTFE</p>	<p>DESCRIPTION: MCX STRAIGHT CABLE JACK, RG174 & RG316- 50 OHM DWG. NO. MCX-J-C-X-ST-CA1</p>	
<p>BY: R MUSSER 02/06/2008 SHEET 1 OF 2</p>		

REVISION K

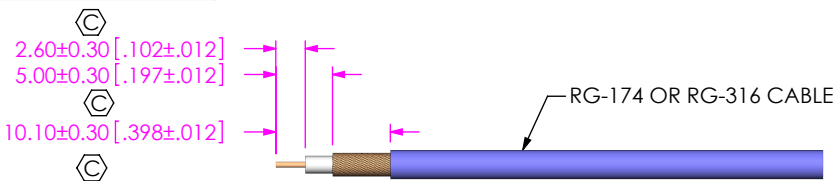

IN-PROCESS 1
STRIP AND TIN INNER CONDUCTOR

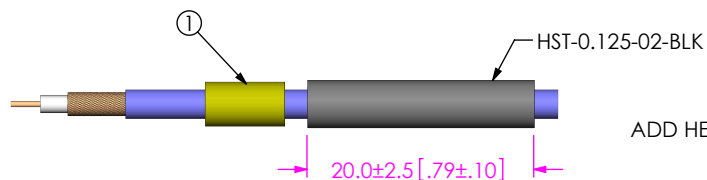

IN-PROCESS 2
ADD HEAT SHRINK TUBE AND FERRULE



IN-PROCESS 3
SOLDER SIGNAL SOCKET

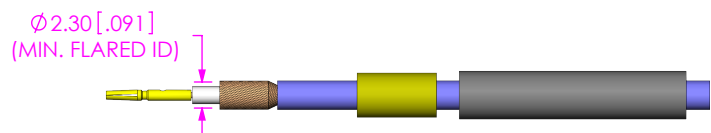

IN-PROCESS 4
FLARE SHIELD

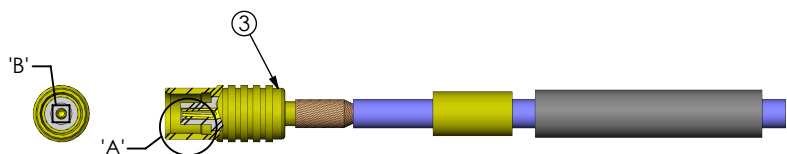

IN-PROCESS 5
ADD SUB ASSEMBLY

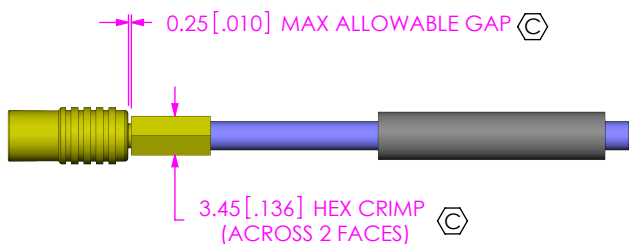

IN-PROCESS 6
CRIMP FERRULE
(USE RF CRIMP HAND TOOL # CAT-HT-126667-21)

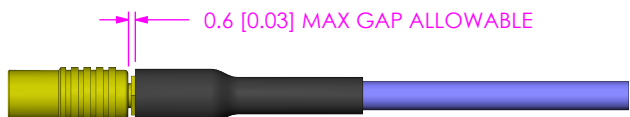

IN-PROCESS 7
APPLY HEAT SHRINK TUBING

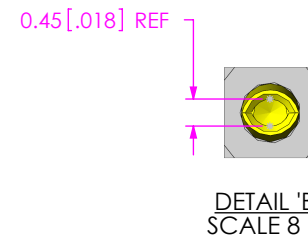
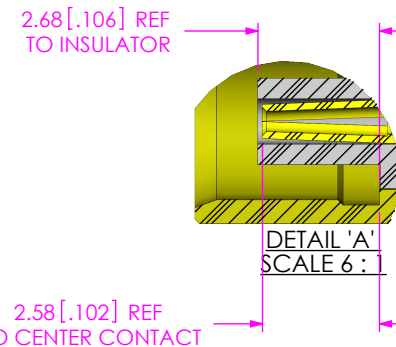

PROPRIETARY NOTE

THIS DOCUMENT CONTAINS INFORMATION CONFIDENTIAL AND PROPRIETARY TO SAMTEC, INC. AND SHALL NOT BE REPRODUCED OR TRANSFERRED TO OTHER DOCUMENTS OR DISCLOSED TO OTHERS OR USED FOR ANY PURPOSE OTHER THAN THAT WHICH IT WAS OBTAINED WITHOUT THE EXPRESSED WRITTEN CONSENT OF SAMTEC, INC.

DO NOT SCALE DRAWING

SHEET SCALE: 1:0.666667



520 PARK EAST BLVD, NEW ALBANY, IN 47150
PHONE: 812-944-6733 FAX: 812-948-5047
e-Mail: info@SAMTEC.com code: 55322

DESCRIPTION:
MCX STRAIGHT CABLE JACK, RG174 & RG316- 50 OHM
DWG. NO.

MCX-J-C-X-ST-CA1

BY: R MUSSER 02/06/2008 SHEET 2 OF 2