

**PLUG MATED TO R/A RECEPTACLE
MATED PROFILE**

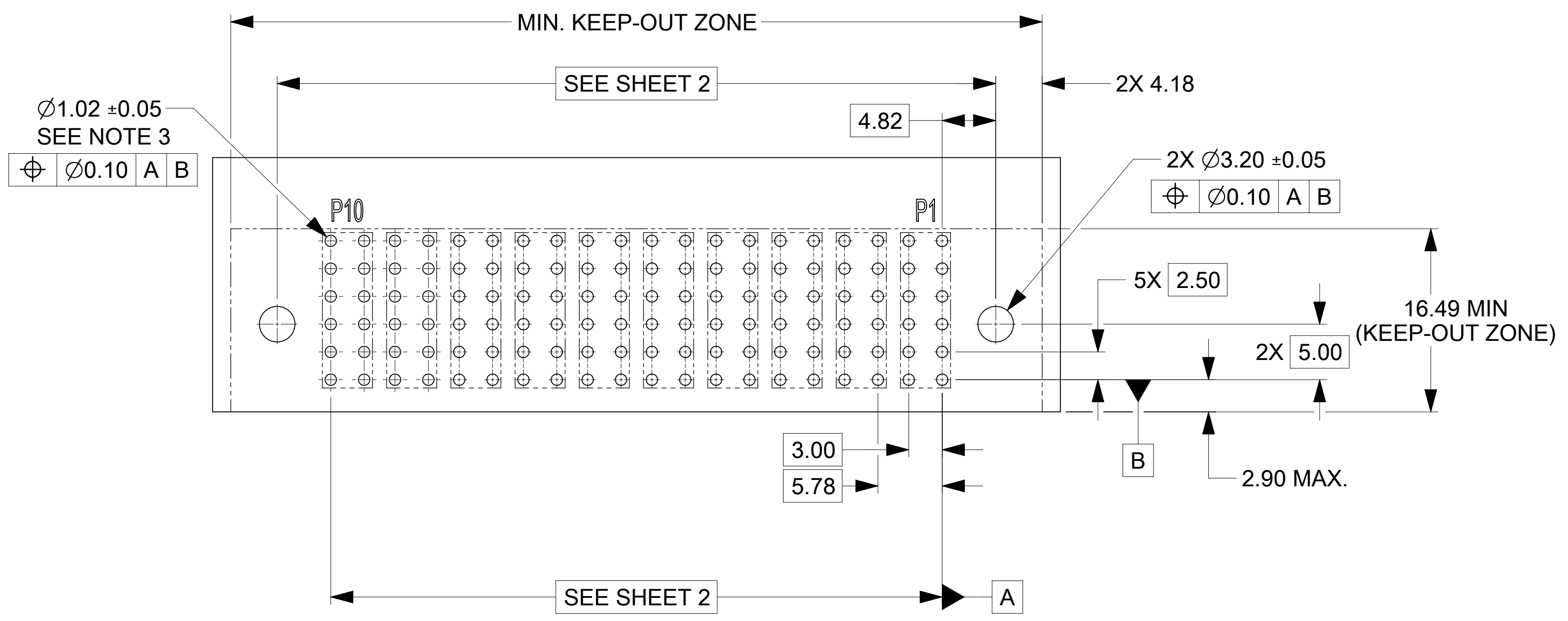

RECOMMENDED PCB LAYOUT AND KEEP-OUT ZONE

- NOTES:**
- MATERIAL:**
 - HOUSINGS: LCP UL94, V-0, COLOR : BLACK
 - TERMINALS: HIGH CONDUCTIVITY COPPER ALLOY
 - PLATING: 1.27 μm (50 μin) NICKEL OVERALL WITH 2.54 μm (100 μin) SELECTIVE TIN ON TAILS AND 0.762 μm (30 μin) SELECTIVE GOLD ON CONTACT AREA
 - PACKAGING:** ASSEMBLIES TO BE TRAY PACKED PER PACKAGING SPEC: 2141150010-PK.
 - PLATED THRU HOLE SIZE,** REFER TO PRODUCT SPEC. FOR DETAILS.
 - PRODUCT SPEC:** 2141130000-PS.
 - PRODUCT TO MEET RoHS REQUIREMENTS.**
 - VERTICAL ASSEMBLY MATES TO MOLEX PLUG 219562XXXX-SD, SEE DRAWING FOR DETAILS.**
 - TAIL DESIGN: COMPLIANT PIN.**
 - POWER TERMINALS ARE LUBRICATED.**
 - APPLICATION SPECIFICATION: 2141130000-AS (FOR COMPLIANT TAILS ONLY).**

| | | | | | | | | | |
|---|--------|---|--------------------|------------|-----------------|----------|--------------|--|--|
| THIS DRAWING CONTAINS INFORMATION THAT IS PROPRIETARY TO MOLEX ELECTRONIC TECHNOLOGIES, LLC AND SHOULD NOT BE USED WITHOUT WRITTEN PERMISSION | | | | | | | | | |
| DIMENSION UNITS | SCALE | CURRENT REV DESC: | | | | | | | |
| mm | 3:1 | <p>molex</p> <p>GUARDIAN HD REC POWER ONLY PF</p> <p>PRODUCT CUSTOMER DRAWING</p> <p>DOCUMENT NUMBER: 2195649000-SD DOC TYPE: PSD DOC PART: 000 REVISION: A3</p> | | | | | | | |
| GENERAL TOLERANCES (UNLESS SPECIFIED) | | | | | | | | | |
| ANGULAR TOL | ± ° | | | | | | | | |
| 4 PLACES | ± | | | | | | | | |
| 3 PLACES | ± | | | | | | | | |
| 2 PLACES | ± 0.25 | EC NO: 745288 | DRWN: LZABJANOVSKI | 2023/03/24 | | | | | |
| 1 PLACE | ± 0.3 | CHK'D: JAYK1 | APPR: JAYK1 | 2023/04/10 | | | | | |
| 0 PLACES | ± | INITIAL REVISION: | DRWN: LZABJANOVSKI | 2022/03/31 | | | | | |
| DRAFT WHERE APPLICABLE MUST REMAIN WITHIN DIMENSIONS | | THIRD ANGLE PROJECTION | DRAWING | SERIES | MATERIAL NUMBER | CUSTOMER | SHEET NUMBER | | |
| | | | D-SIZE | 219564 | SEE CHART | | 1 OF 2 | | |

| PART NUMBER | CONFIGURATION | QUANTITY PER CARTON (DU) |
|-------------|---------------|--------------------------|
| 219564-0001 | G+1P+G | 195 |

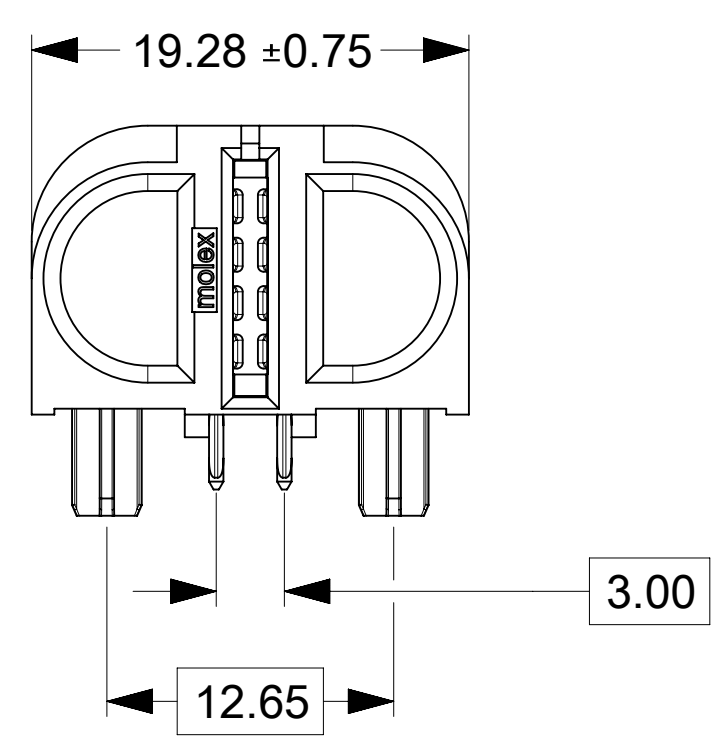

| PART NUMBER | CONFIGURATION | QUANTITY PER CARTON (DU) |
|-------------|---------------|--------------------------|
| 219564-0002 | G+2P+G | 150 |

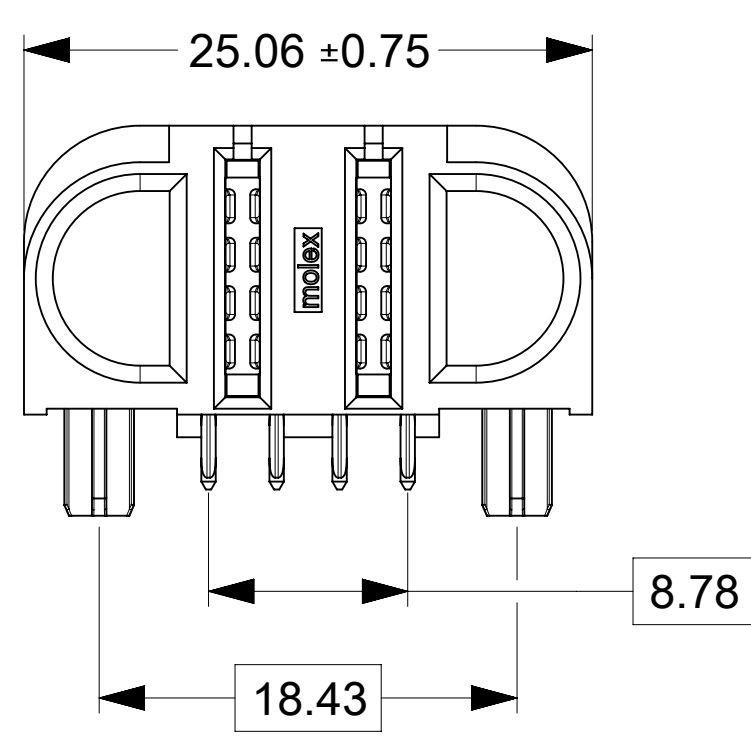

| PART NUMBER | CONFIGURATION | QUANTITY PER CARTON (DU) |
|-------------|---------------|--------------------------|
| 219564-0003 | G+3P+G | 120 |

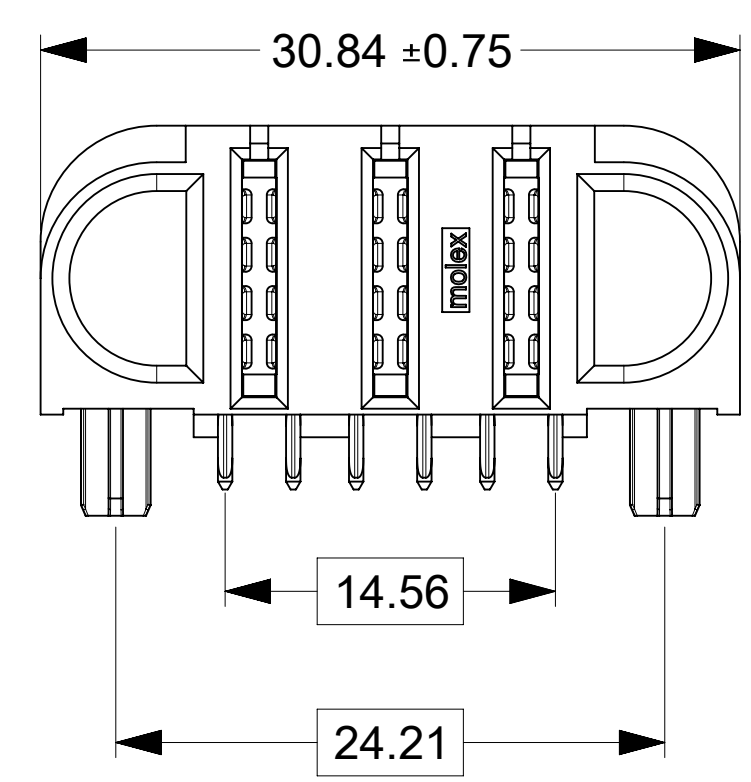

| PART NUMBER | CONFIGURATION | QUANTITY PER CARTON (DU) |
|-------------|---------------|--------------------------|
| 219564-0004 | G+4P+G | 105 |

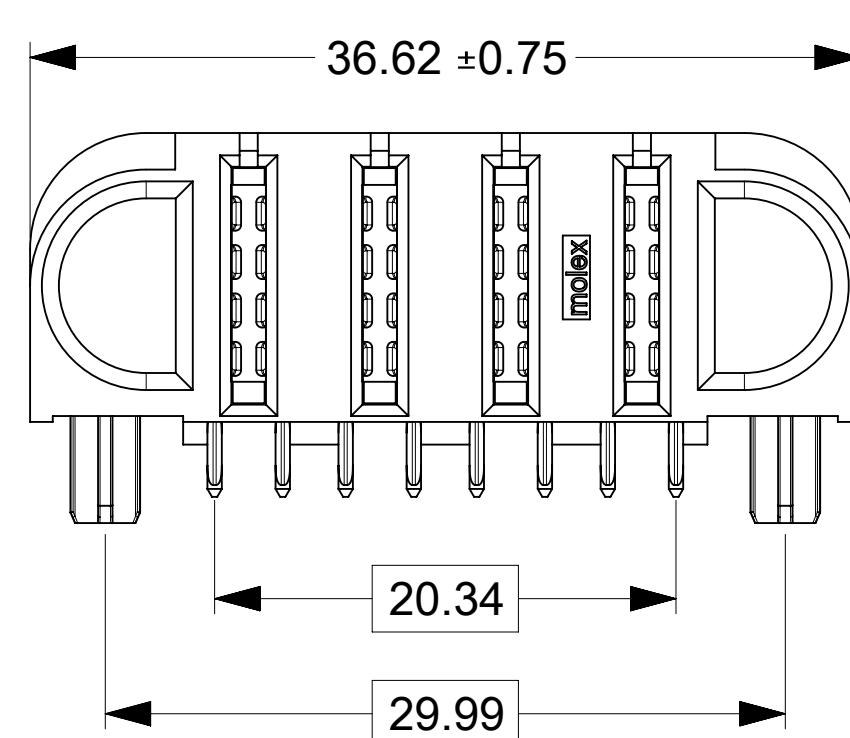

| PART NUMBER | CONFIGURATION | QUANTITY PER CARTON (DU) |
|-------------|---------------|--------------------------|
| 219564-0005 | G+5P+G | 90 |

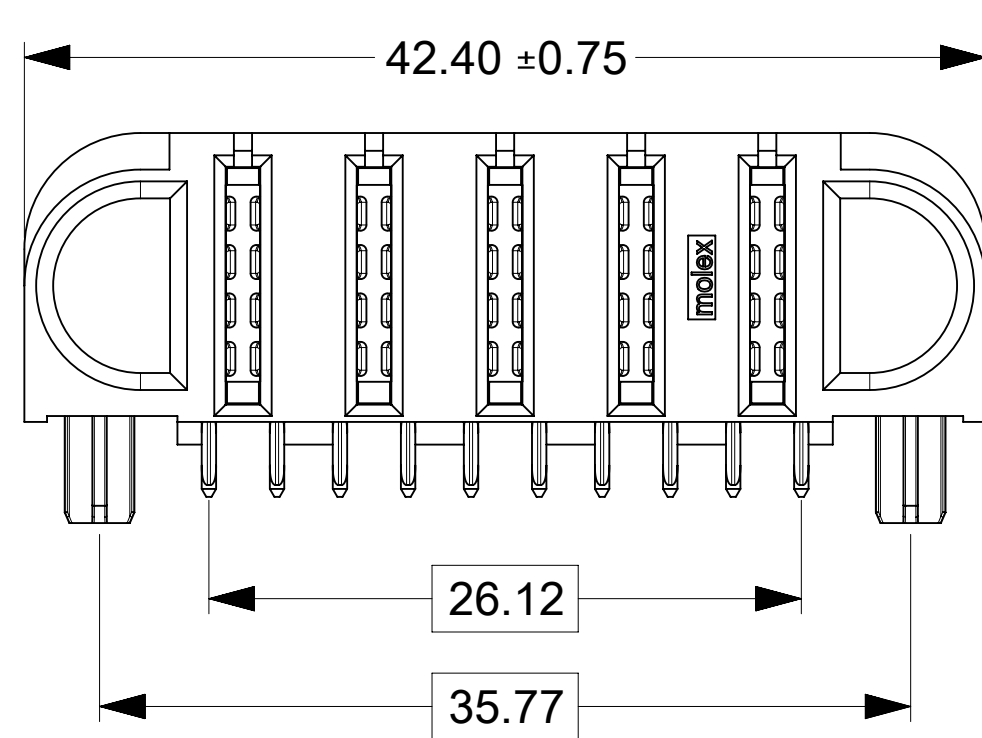

| PART NUMBER | CONFIGURATION | QUANTITY PER CARTON (DU) |
|-------------|---------------|--------------------------|
| 219564-0006 | G+6P+G | 75 |

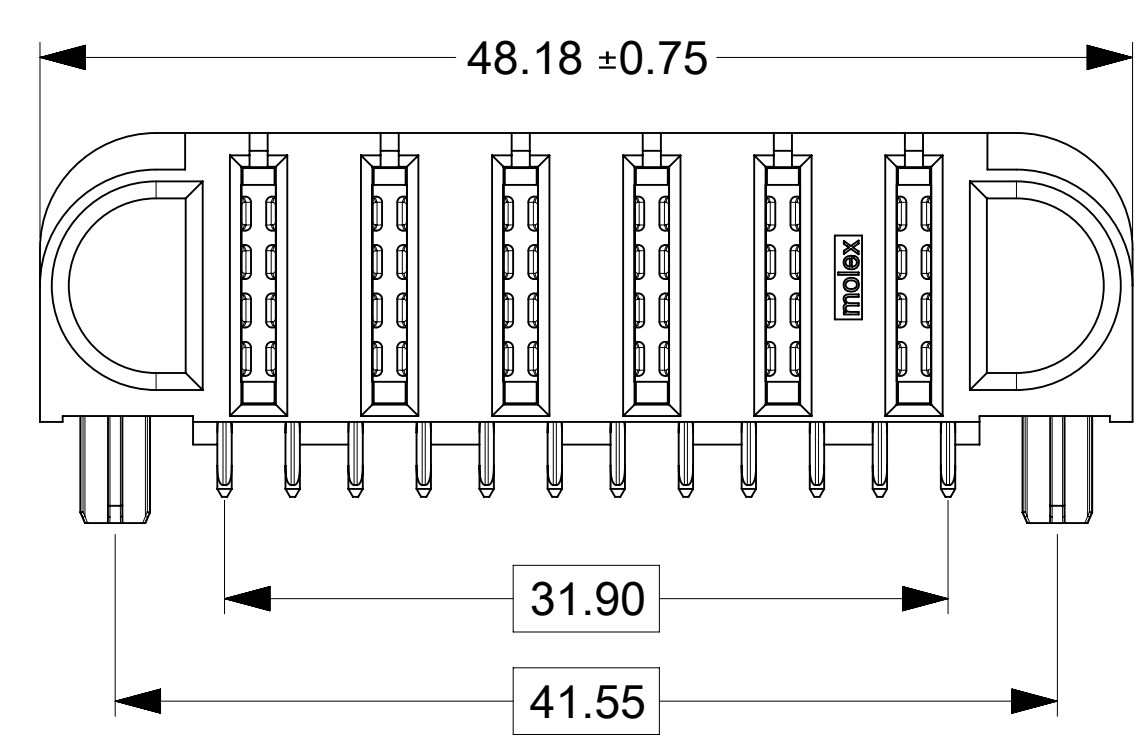

| PART NUMBER | CONFIGURATION | QUANTITY PER CARTON (DU) |
|-------------|---------------|--------------------------|
| 219564-0007 | G+7P+G | 60 |

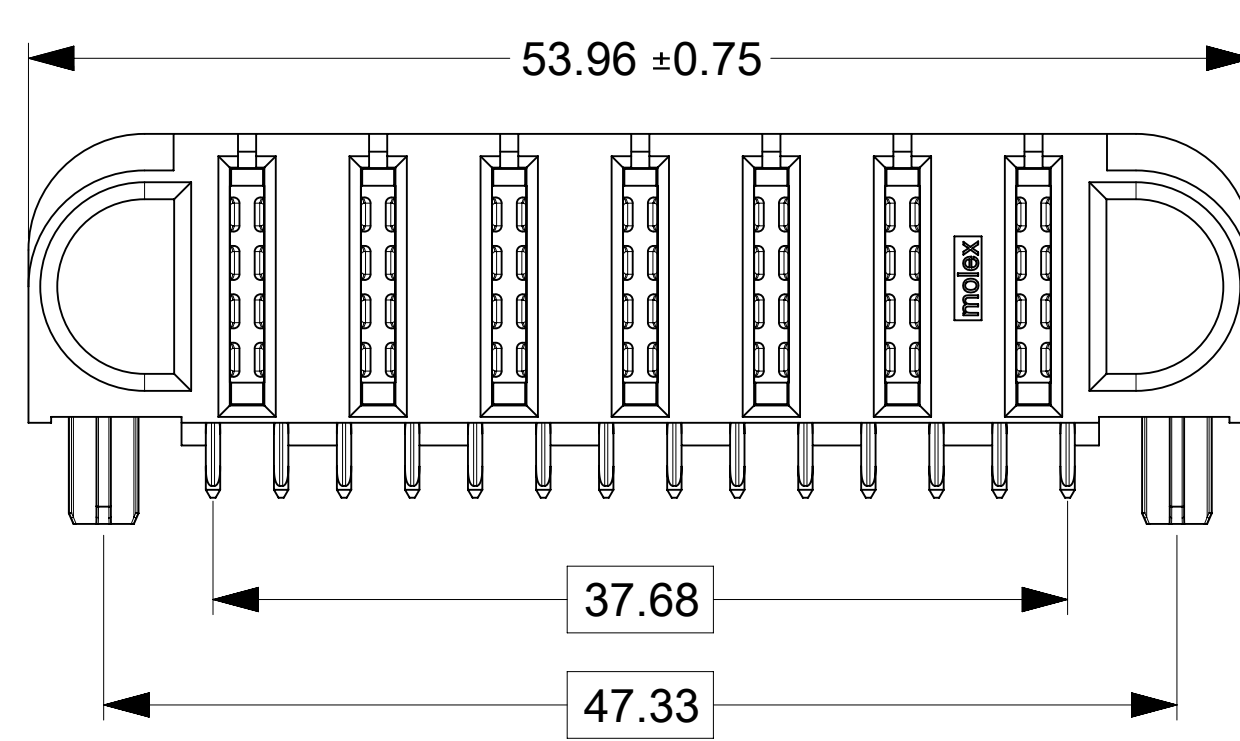

| PART NUMBER | CONFIGURATION | QUANTITY PER CARTON (DU) |
|-------------|---------------|--------------------------|
| 219564-0008 | G+8P+G | 60 |

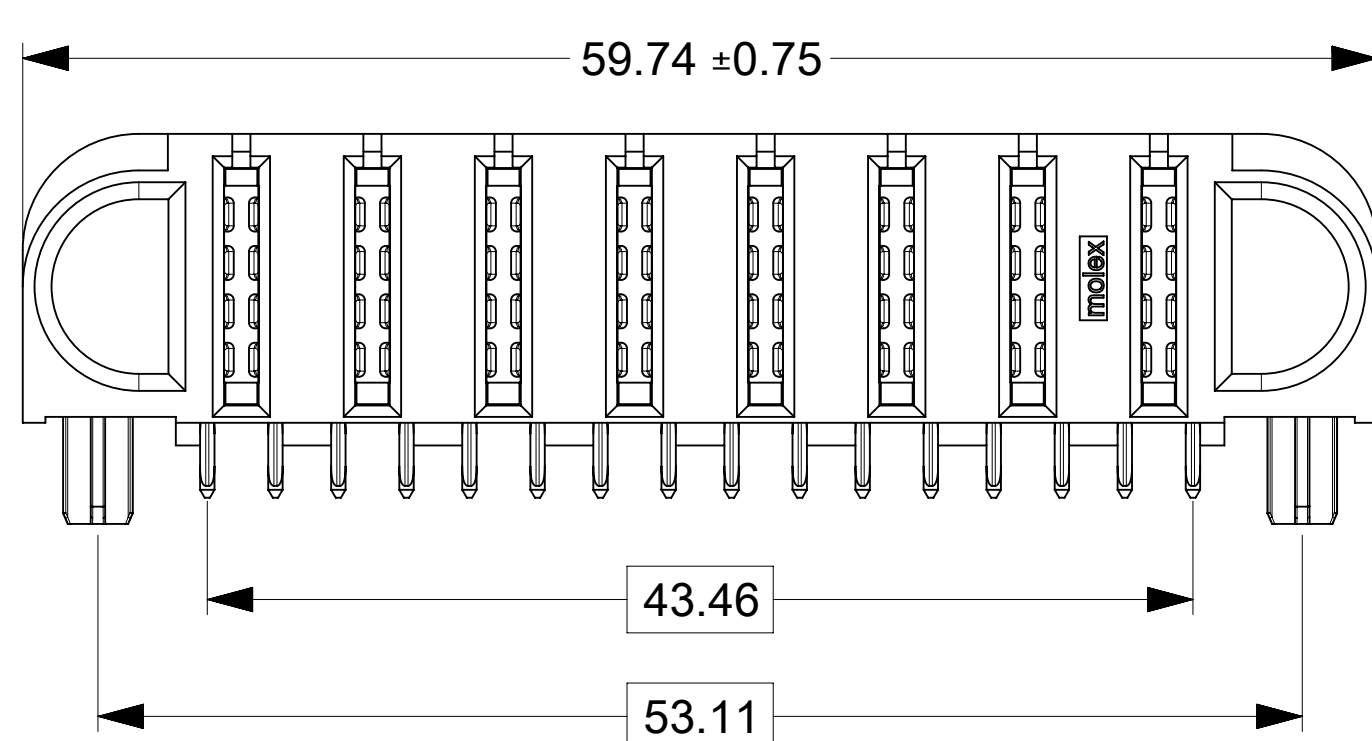

| PART NUMBER | CONFIGURATION | QUANTITY PER CARTON (DU) |
|-------------|---------------|--------------------------|
| 219564-0009 | G+9P+G | 45 |

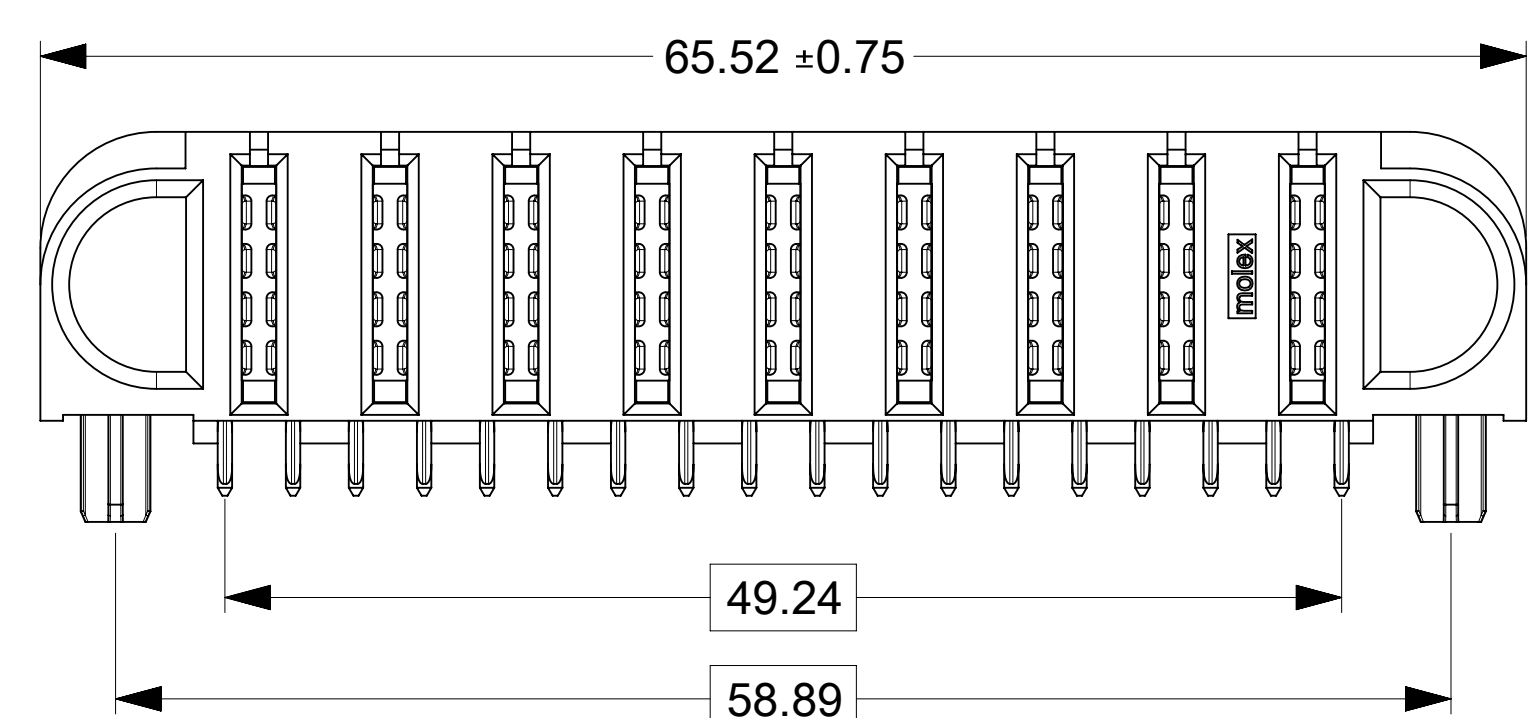

| PART NUMBER | CONFIGURATION | QUANTITY PER CARTON (DU) |
|-------------|---------------|--------------------------|
| 219564-0010 | G+10P+G | 45 |

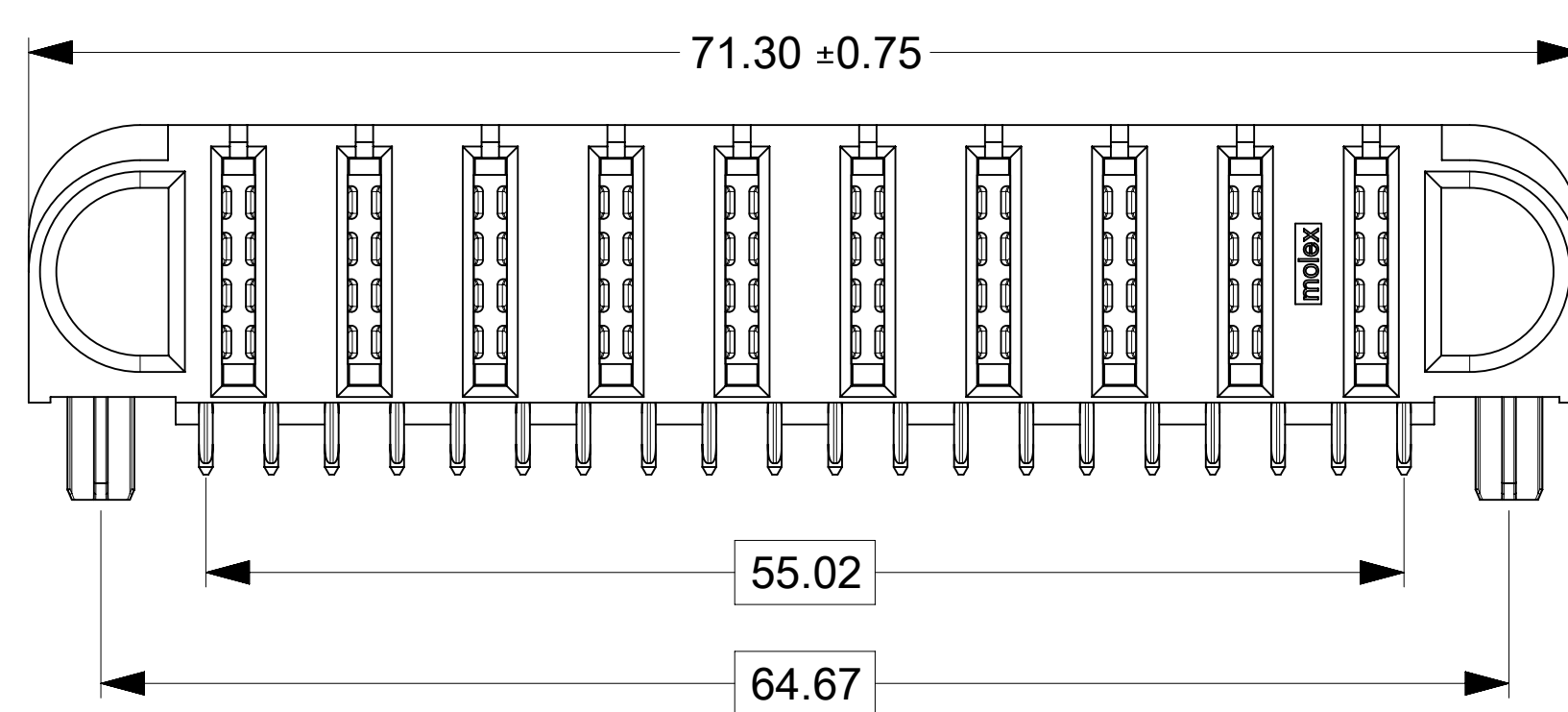

THIS DRAWING CONTAINS INFORMATION THAT IS PROPRIETARY TO MOLEX ELECTRONIC TECHNOLOGIES, LLC AND SHOULD NOT BE USED WITHOUT WRITTEN PERMISSION

| | | |
|---------------------------------------|------------------------|-------------------|
| DIMENSION UNITS | SCALE | CURRENT REV DESC: |
| mm | 3:1 | |
| GENERAL TOLERANCES (UNLESS SPECIFIED) | | |
| ANGULAR TOL | ± | ° |
| 4 PLACES | ± | |
| 3 PLACES | ± | |
| 2 PLACES | ± | 0.25 |
| 1 PLACE | ± | 0.3 |
| 0 PLACES | ± | |
| DRAFT WHERE APPLICABLE | THIRD ANGLE PROJECTION | DRAWING |
| MUST REMAIN WITHIN DIMENSIONS | | D-SIZE |

| | | |
|--------------------|--------------------|------------|
| EC NO: 745288 | DRWN: LZABJANOVSKI | 2023/03/24 |
| CHK'D: JAYK1 | 2023/04/10 | |
| APPR: JAYK1 | 2023/04/10 | |
| INITIAL REVISION: | | |
| DRWN: LZABJANOVSKI | 2022/03/31 | |
| APPR: BPISZCZOR | 2022/08/04 | |

| | | | | | |
|-----------------|--|----------|----------|--------------|----------|
| DOCUMENT NUMBER | | | DOC TYPE | DOC PART | REVISION |
| 2195649000-SD | | | PSD | 000 | A3 |
| MATERIAL NUMBER | | CUSTOMER | | SHEET NUMBER | |
| SEE CHART | | | | 2 OF 2 | |

| | | | | |
|-----------------|----|--------------|------------|----------|
| DOCUMENT STATUS | P1 | RELEASE DATE | 2023/04/11 | 17:06:07 |
|-----------------|----|--------------|------------|----------|