

© 1966 BY AMP INCORPORATED. ALL RIGHTS RESERVED. AMP PRODUCTS COVERED BY PATENTS AND/OR PATENTS PENDING.

ZONE	LTR	DESCRIPTION	DATE	APPROVED
	A	REVISED	Y-755	9-12-66 M.S. D.H.
	A1	REVISED	2622	8-6-70 M.S. D.H.
	B	REVISED	3131	8-13-71 M.S. R.F.
	C	REVISED FINISH	7225 m/s	2-26-81 R.O.
	D	REV PER 0600-6466-97	II	10-98 [Signature]

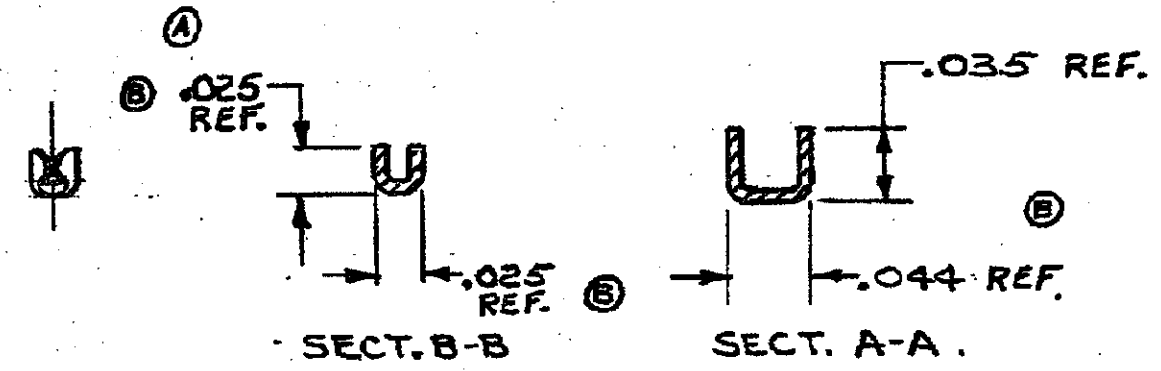
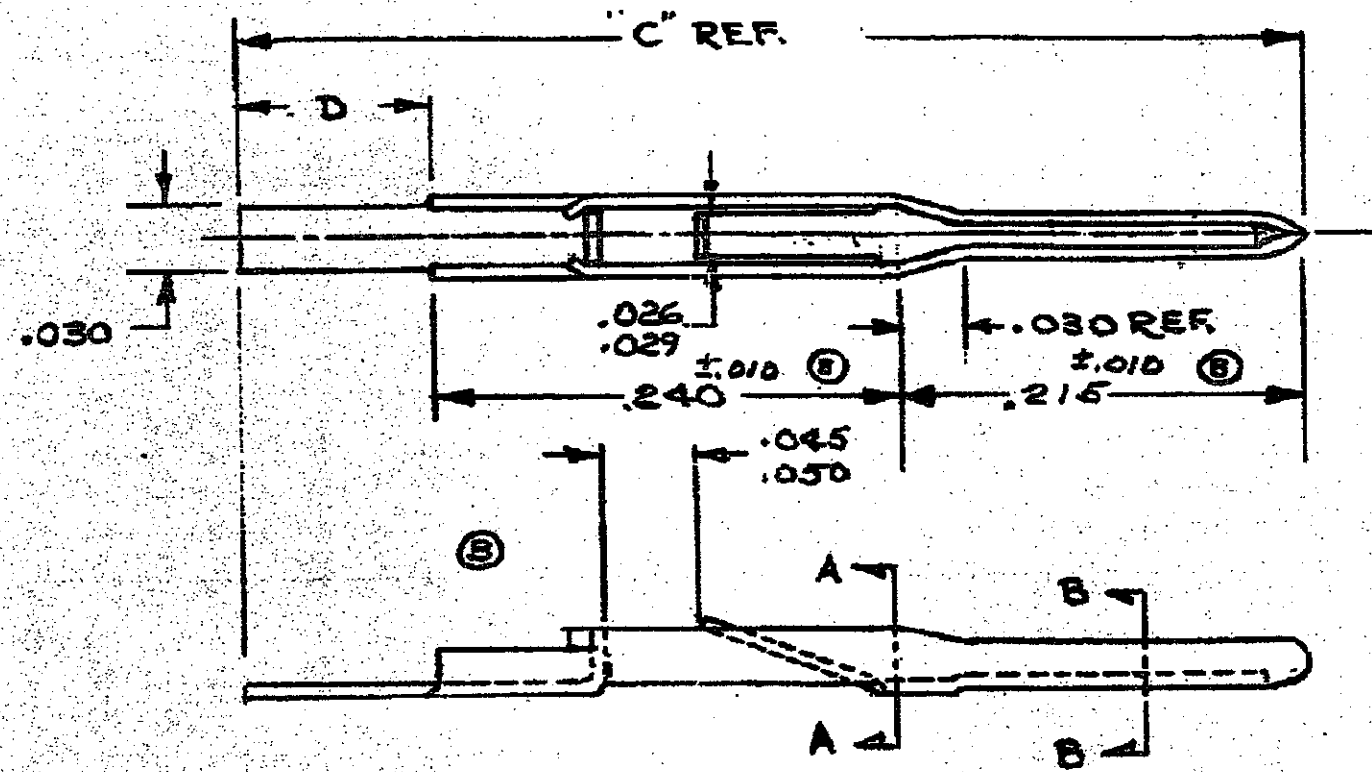

- ① .00003 GOLD OVER .00005 NICKEL IN CONTACT AREA, TIN-LEAD OVER NICKEL IN TAIL AREA.
- ② .00005 GOLD OVER .00005 NICKEL IN CONTACT AREA, TIN-LEAD OVER NICKEL IN TAIL AREA.

①	202947-3	.140	.595	BRASS	△
085	202947-2	.140	.595	BRASS	△
	PART NO.	"D"	"C"	MATERIAL	FINISH

UNLESS OTHERWISE SPECIFIED DIM. ARE IN INCHES. TOLERANCES ON DECIMALS ± .005 ANGLES ±		CONTRACT NO. 3-25-66		AMP INCORPORATED HARRISBURG, PENNSYLVANIA	
MATERIAL SEE TABLE		DR. D.S. Heide 4/4/66		NAME CONTACT PIN	
HEAT TREAT FINISH SEE TABLE		APPR. [Signature] 4/4/66		SERIAL CODE IDENT NO. B 00779	
LOG DEF. FO		DATE 7.6.1966		NUMBER 202947	
		SCALE 10-1		WY CALC ACTUAL SHEET	

CUSTOMER DRAWING