

ELECTRICAL SPECIFICATIONS

Antenna Model	VFH69383B23JW-518J					
Number of Ports	6					
Port Configuration	2x- 3G/4G/ISM/CBRS			3x- Wi-Fi		
Operating Frequency (MHz)	698-806	824-894	880-960	1690-3800	2400-2500	4900-6000
Peak Gain* – Avg (dBi)	0.4	0.8	1.2	4.0	2.6	6.6
Peak Gain* – Max (dBi)	1.6	1.4	1.5	7.2	3.1	7.5
VSWR** – Avg	<1.6:1	<1.5:1	<1.5:1	<1.3:1	<1.3:1	<1.2:1
VSWR** – Max	<2.0:1			<2.0:1		
Isolation LTE1 to LTE2 (dB)	-17	-17	-17	-22	-30	-42
Isolation LTE1 to WIFI 1 (dB)	-36	-36	-38	-21	-21	-42
Isolation LTE1 to WIFI 2 (dB)	-40	-44	-45	-22	-22	-42
Isolation LTE1 to WIFI 3 (dB)	-19	-21	-24	-30	-36	-47
Isolation LTE2 to WIFI 1 (dB)	-37	-42	-43	-21	-21	-42
Isolation LTE2 to WIFI 2 (dB)	-35	-35	-37	-21	-21	-41
Isolation LTE2 to WIFI 3 (dB)	-16	-18	-19	-26	-36	-47
Isolation WIFI 1 to WIFI 2 (dB)	-58	-59	-58	-37	-38	-46
Isolation WIFI 1 to WIFI 3 (dB)	-41	-44	-47	-38	-38	-46
Isolation WIFI 2 to WIFI 3 (dB)	-40	-42	-42	-35	-36	-45
Isolation GNSS to LTE 1 (dB)	-41	-50	-51	-41	-52	-52
Isolation GNSS to LTE 2 (dB)	-42	-42	-41	-49	-53	-54
Isolation GNSS to WIFI 1 (dB)	-69	-71	-66	-52	-54	-49
Isolation GNSS to WIFI 2 (dB)	-67	-69	-69	-51	-52	-54
Isolation GNSS to WIFI 3 (dB)	-40	-45	-44	-48	-56	-61
Azimuth Plane 3 dB Beamwidth	360°, Omnidirectional					
Nominal Impedance (Ohms)	50					
Polarization	Linear Vertical					
Max Power - Ambient 25°C (W)	10					



MECHANICAL SPECIFICATIONS

Dimensions – LxWxH – mm (in.)	179 x 63 x 48 (7.04 x 2.48 x 1.69)
Weight – kg (lbs.)	0.72 (1.6)
Cable Type	LMR 100, Black
Mounting	P-Mount
Radome Material	PC, UL94-V0
Baseplate Material	Aluminum

ENVIRONMENTAL SPECIFICATIONS

Operating Environment	Outdoor Vehicle
Operating Temperature – °C (°F)	-30 to +70°C (-22 to +158°F)
Storage Temperature – °C (°F)	-40 to +85°C (-40 to +185°F)
Ingress Protection Rating	IP67
Material Substance Compliance	RoHS

GNSS ANTENNA SPECIFICATIONS

Frequency of Operation (MHz)	1559 - 1606		
	BEIDOU	GPS	GLONASS
Band	1559.052 - 1563.144	1574.42 - 1576.42	1598.0625 - 1605.89
Frequency Band (MHz)			
Absolute Gain (dBi)	2	2	2
LNA Gain, Typ. @ room temp. (dBi)	26	27	26
Noise Figure @ room temp., Max (dB)	3.0	2.5	2.8
Max VSWR @ room temp.	2:1	2:1	2:1
Polarization	RHCP		
Nominal Impedance (Ohms)	50		
DC Voltage (Vdc)	3.3		
Operating Supply Voltage (Vdc)	2.5 - 7.0		
Current Consumption, Max @ room temp mA)	20		
Out-of-band Signal Rejection Min @ room temp (dBc)	60 (@1-1525 MHz)	60 (@1675-2000 MHz)	50 (@2000-3000 MHz)
Input Max Power (dBm)	-30		
Cable Type	RG14		

SAFETY

The VFH69383B23JW and all associated equipment should be installed in accordance with all applicable local and national electrical code guidelines to ensure safe operation.

APPLICATION

The VFH69383B23JW antenna provides an excellent solution for Public Safety, Transportation and After Market Fleet applications with an integration of wide range of frequencies within one aerodynamic housing. This 6-port antenna is configured for 2x MIMO operation over 3G/4G/ISM/CBRS frequencies, 3x MIMO operation over both Low/High Band WiFi and 1x port that provides an active antenna for enabling GNSS global navigational services.

LOCATION

The antenna should be mounted on the desired location before connecting the cable. This is to ensure that the cable is not twisted or damage during the mounting of the antenna.

MOUNTING

- The mounting area should be clean of any debris, clear from obstructions and as flat as possible.
- Punch or drill a 21-millimeter hole in the roof of the vehicle noting that a 300-millimeter clearance radius around the antenna is recommended.
- The recommended orientation is facing the front of the vehicle with cables facing the rear: see illustration below.
- Feed the cables from the bottom of the antenna through the topside of the 21 mm hole. Peel the adhesive covering on the bottom side of the antenna's gasket. Place the threads of the antenna through the hole so that the gasket of the antenna is flat on the vehicle surface. Slide the lock-nut and washer around the cables and finger-tighten to the stud of the antenna. Tighten the nut with a wrench using 30 Nm of torque.
- Use a short service loop (slack) with tie-downs to secure the antenna cables such that any force or movement will not be transmitted to the antenna connectors or the apparatus. Minimum bending radius for the cable exiting the bottom of the antenna is 10 mm.

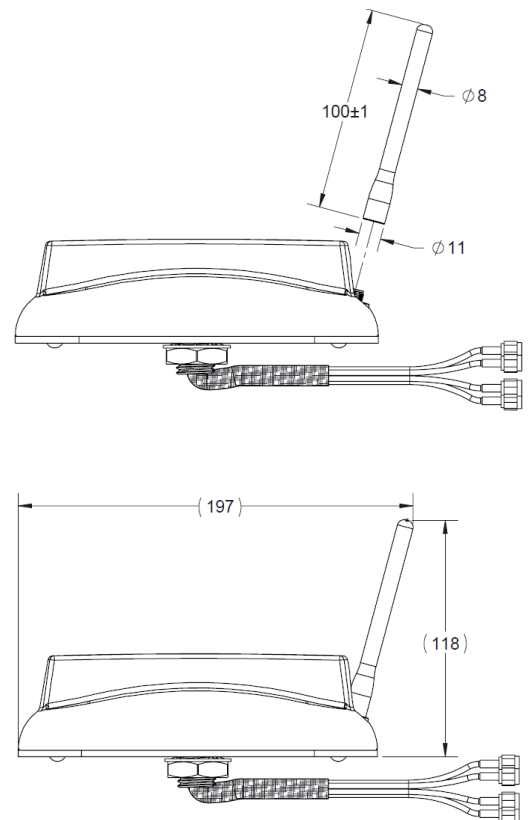
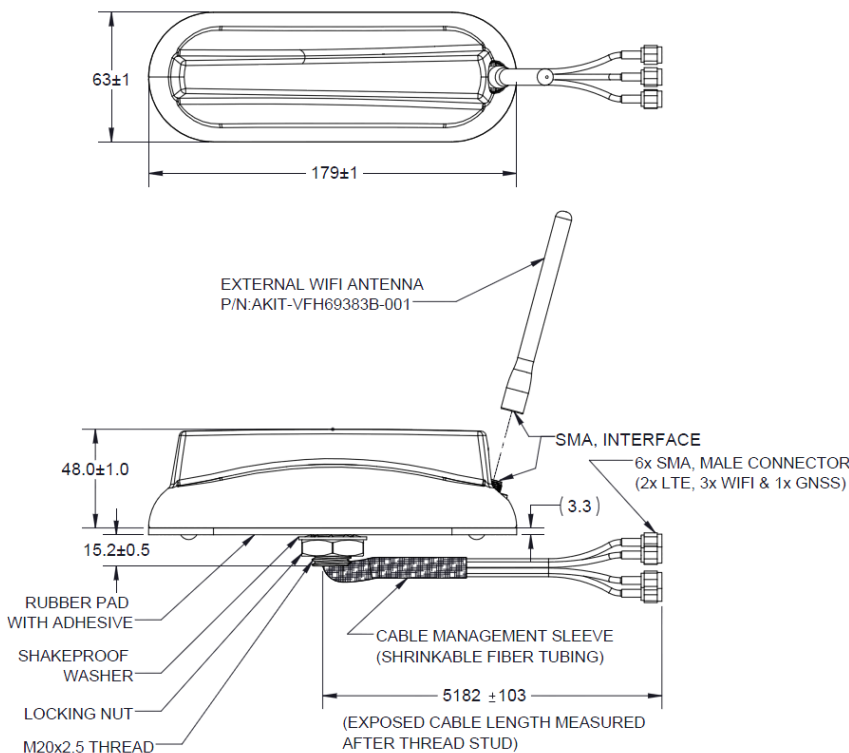

RoHS

Laird warrants to the original end user customer of its products that its products are free from defects in material and workmanship. Subject to conditions and limitations Laird will, at its option, either repair or replace any part of its products that prove defective because of improper workmanship or materials. This limited warranty is in force for the useful lifetime of the original end product into which the Laird product is installed. Useful lifetime of the original end product may vary but is not to exceed five (5) years from the original date of the end product purchase.

Any information furnished by Laird Inc. and its agents is believed to be accurate and reliable. All specifications are subject to change without notice. Responsibility for the use and application of Laird materials rests with the end user, since Laird and its agents cannot be aware of all potential uses. Laird makes no warranties as to the fitness, merchantability or suitability of any Laird materials or products for any specific or general uses. Laird shall not be liable for incidental or consequential damages of any kind. All Laird products are sold pursuant to the Laird Terms and Conditions of sale in effect from time to time, a copy of which will be furnished upon request.

© Copyright 2019 Laird Inc. All Rights Reserved. Laird, Laird Technologies, the Laird Logo, and other marks are trademarks or registered trademarks of Laird Inc. or an affiliate company thereof. Other product or service names may be the property of third parties. Nothing herein provides a license under any Laird or any third-party intellectual property rights.

sales@lairdconnect.com
support@lairdconnect.com
www.lairdconnect.com

