

REVISION HISTORY				
ECO	REV	DESCRIPTION	APPROVED	DATE
-	3	PRODUCTION	MITCHELL LEE	05/01/2012

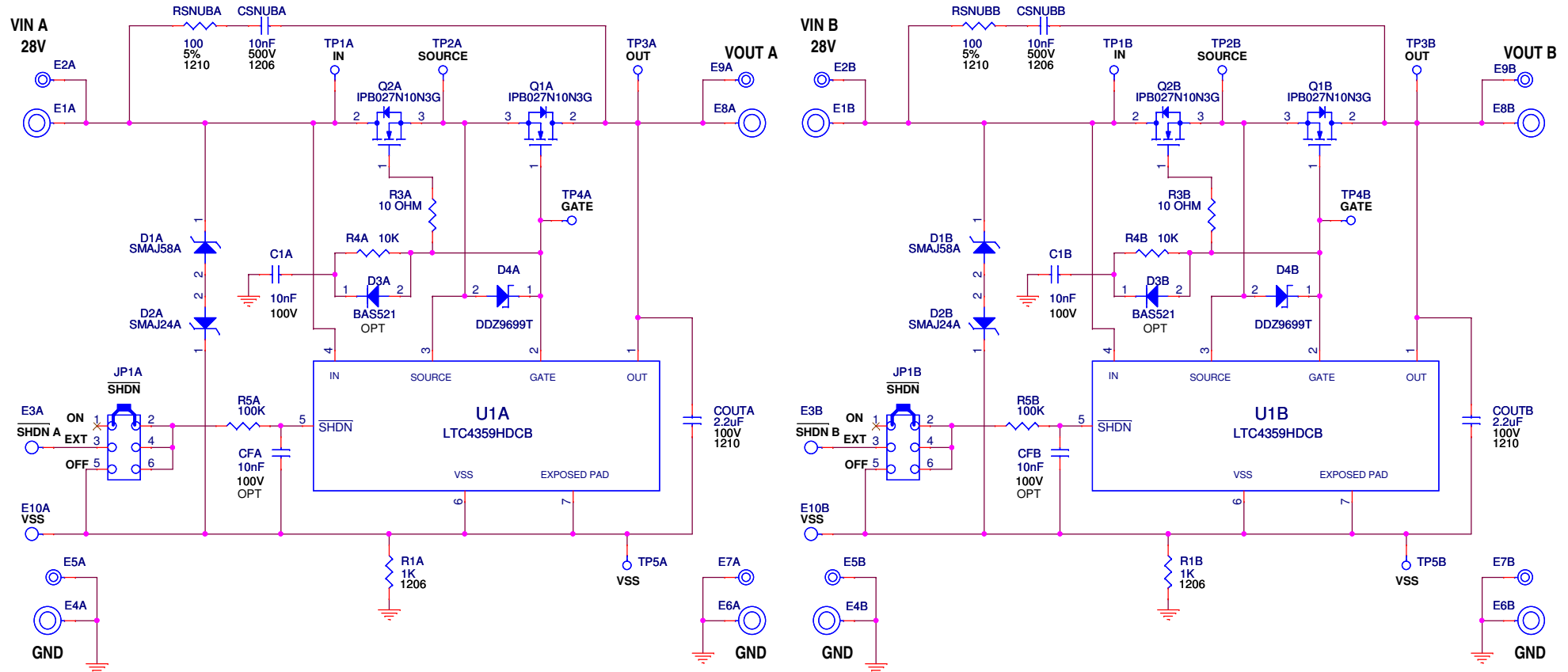

NOTE: LTC4359HDCB TOP MARK LFKF.
ALL RESISTORS AND CAPACITORS ARE 0805 PACKAGE U.O.N.

INPUT VOLTAGE LIMITS	
OPERATING	4.5V to 60V
DC SURVIVAL	-40V to 75V
500ms SURGE	-65V to 100V
VIN - VOUT	-100V

OUTPUT CURRENT CAPABILITY	
VIN	MAXIMUM CONTINUOUS LOAD
4.5V to 8V	10A
≥ 8V	20A

<p>CUSTOMER NOTICE</p> <p>LINEAR TECHNOLOGY HAS MADE A BEST EFFORT TO DESIGN A CIRCUIT THAT MEETS CUSTOMER-SUPPLIED SPECIFICATIONS; HOWEVER, IT REMAINS THE CUSTOMER'S RESPONSIBILITY TO VERIFY PROPER AND RELIABLE OPERATION IN THE ACTUAL APPLICATION. COMPONENT SUBSTITUTION AND PRINTED CIRCUIT BOARD LAYOUT MAY SIGNIFICANTLY AFFECT CIRCUIT PERFORMANCE OR RELIABILITY. CONTACT LINEAR TECHNOLOGY APPLICATIONS ENGINEERING FOR ASSISTANCE.</p>		<p>APPROVALS</p>		<p>1630 McCarthy Blvd. Milpitas, CA 95035 Phone: (408)432-1900 www.linear.com Fax: (408)434-0507 LTC Confidential-For Customer Use Only</p>
		PCB DES.	M.HAWKINS	
<p>THIS CIRCUIT IS PROPRIETARY TO LINEAR TECHNOLOGY AND SUPPLIED FOR USE WITH LINEAR TECHNOLOGY PARTS.</p>		<p>SCALE = NONE</p>		<p>TITLE: SCHEMATIC</p> <p>28V/20A IDEAL DIODE AND SWITCH WITH REVERSE INPUT PROTECTION</p> <p>SIZE N/A IC NO. LTC4359HDCB</p> <p>DEMO CIRCUIT 1676A</p> <p>DATE: 05/01/2012</p>
				<p>REV. 3</p> <p>SHEET 1 OF 1</p>