

DESCRIPTION: FEMALE - SOLDER CUP / MACHINED - PREMIUM

WILL ACCEPT 26-20 AWG WIRE

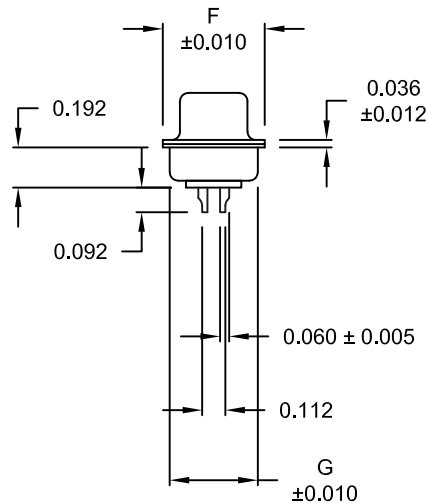
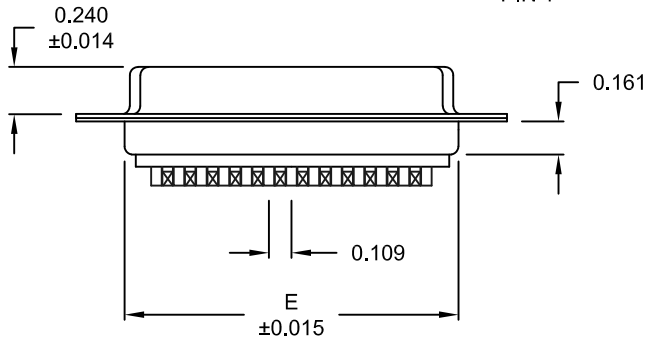
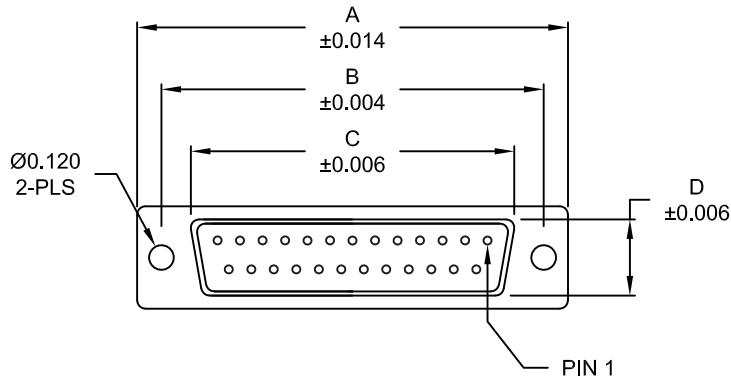

**MATERIAL:**

SHELL: STEEL, TIN PLATED  
 INSULATOR: UL 94V-O RATED, PA6T  
 PROCESS TEMP.: 260°C  
 CONTACT: BRASS

**ELECTRICAL:**

CURRENT RATING: 5 AMPS  
 CONTACT RESISTANCE: 15 mOhms Max.  
 INSULATION RESISTANCE: 1,000 MOhms Min.  
 VOLTAGE: 500VAC FOR 1 MINUTE  
 TEMPERATURE: -50° C TO 100° C

RoHS COMPLIANT

**DIMENSIONS**

No. OF PINS	A	B	C	D	E	F	G
9	1.213	0.984	0.642	0.315	0.760	0.496	0.429
	30.80	24.99	16.30	8.00	19.30	12.60	10.90
15	1.541	1.312	0.969	0.315	1.083	0.496	0.429
	39.15	33.32	24.60	8.00	27.51	12.60	10.90
25	2.088	1.852	1.512	0.315	1.630	0.496	0.429
	53.04	47.04	38.40	8.00	41.40	12.60	10.90
37	2.729	2.500	2.157	0.315	2.276	0.496	0.429
	69.32	63.50	54.80	8.00	57.81	12.60	10.90
50	2.635	2.406	2.059	0.425	2.182	0.598	0.535
	66.93	61.11	52.30	10.80	55.42	15.20	13.60

172-YYY-202RYY1

SERIES \_\_\_\_\_  
 POSITIONS \_\_\_\_\_  
 009 \_\_\_\_\_  
 015 \_\_\_\_\_  
 025 \_\_\_\_\_  
 037 \_\_\_\_\_  
 050 \_\_\_\_\_  
 GENDER \_\_\_\_\_  
 2 = FEMALE  
 TERMINATION \_\_\_\_\_  
 0 = SOLDER CUP  
 SHELL PLATING \_\_\_\_\_  
 2 = TIN  
 RoHS COMPLIANT \_\_\_\_\_  
 HARDWARE OPTIONS \_\_\_\_\_  
 00 = NO HARDWARE  
 01 = .065" CLINCH NUT (BOARD SIDE)  
 02 = .250" CLINCH NUT (BOARD SIDE)  
 03 = .250" CLINCH NUT (MOUNTING SIDE)  
 05 = .237" 4-40 BOARD LOCK  
 91 = .237" 4-40 SPACER/ BOARD LOCK  
 PLATING OPTIONS \_\_\_\_\_  
 1 = GOLD FLASH  
 2 = 30MICRO-INCH GOLD

DO NOT SCALE FROM DRAWING

	THESE DRAWINGS AND SPECIFICATIONS ARE THE PROPERTY OF NorComp AND SHALL NOT BE REPRODUCED, COPIED OR USED AS THE BASIS FOR THE MANUFACTURE OF SALE OF APPARATUS WITHOUT WRITTEN PERMISSION.		DRAWN: PAM JENKINS	DATE: 08-24-98
	<h1>NorComp</h1>		SCALE: NTS	SHEET 1 OF 2
			DWG NO. 172-YYY-202RYY1	

DESCRIPTION: CLINCH NUT HARDWARE

TOLERANCE:  
ALL DIMENSIONS ARE  $\pm 0.010$

ALL CLINCH-NUTS ARE 4-40 INTERNAL THREADS

01X ..... 0.065" (BOARD SIDE) - CN1

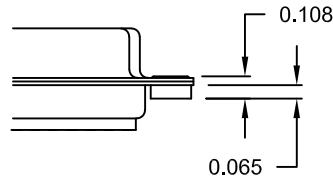

05X ..... 0.237" (BOARD SIDE) - CN10

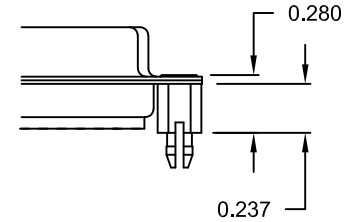

02X ..... 0.250" (BOARD SIDE) - CN2

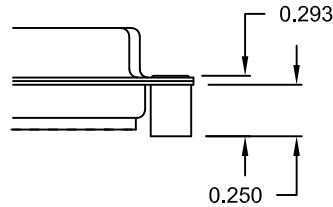

91X ..... 0.237" (BOARD SIDE) - 0.197" MATING SIDE - CN10/SFSO4404

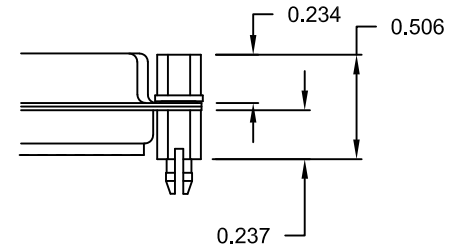

03X ..... 0.250" (MATING SIDE) - CN8

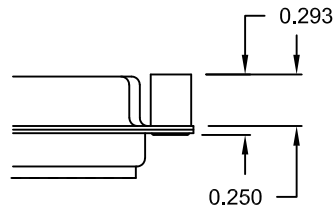

NOTE: 4-40 FEMALE SCREW LOCK IS REMOVABLE

DO NOT SCALE FROM DRAWING

RoHS COMPLIANT

	THESE DRAWINGS AND SPECIFICATIONS ARE THE PROPERTY OF NorComp AND SHALL NOT BE REPRODUCED, COPIED OR USED AS THE BASIS FOR THE MANUFACTURE OF SALE OF APPARATUS WITHOUT WRITTEN PERMISSION.		DRAWN: PAM JENKINS	DATE: 08-24-98
	NorComp		SCALE: NTS	SHEET OF 2 2
			DWG NO. 172-YYY-202RYY1	