



MAX5388 Evaluation System

General Description

The MAX5388 evaluation kit (EV kit) is an assembled and tested PCB that features the MAX5388N 100k Ω dual digital potentiometers. The MAX5388 IC consists of one digital potentiometer in a variable-resistor configuration and one digital potentiometer in a voltage-divider configuration and communicates through an SPI™-compatible serial interface.

The MAX5388EVMINIQU+ evaluation system (EV system) includes the EV kit and the MINIQU+ interface board. The MINIQU+ interface board can be used to enable PC communication through the 3-wire serial interface. Windows® 2000-, Windows XP®, and Windows Vista®-compatible software provides a professional user interface for exercising the MAX5388's features. The program is menu driven and offers a graphical user interface (GUI) complete with buttons, track bars, and edit boxes. The EV kit software can be used to evaluate the MAX5386, MAX5388L, MAX5388M, MAX5391, and MAX5393. The EV kit can also be interfaced directly to a user-supplied 3-wire system.

The MAX5388 IC can be powered from a 2.6V, 3.3V, or 5V source generated from the MINIQU+ interface board and EV kit circuitry, or from a user-supplied external 2.6V to 5.25V DC power supply. Order the MAX5388EVMINIQU+ for a complete PC-based evaluation of the MAX5388.

The EV kit also contains PCB footprints for the MAX5386, MAX5391, and MAX5393. To evaluate these parts, order samples and fit the parts in places U1, U2, and U3, respectively.

SPI is a trademark of Motorola, Inc.

Windows, Windows XP, and Windows Vista are registered trademarks of Microsoft Corp.

Features

- ◆ 2.6V to 5.25V Single-Supply Operation
- ◆ PC USB to 3-Wire Interface or Stand-Alone 3-Wire Serial-Interface Operation
- ◆ Easy-to-Use Menu-Driven Software
- ◆ Includes Windows 2000-, Windows XP-, and Windows Vista-Compatible Software
- ◆ Fully Assembled and Tested

Ordering Information

PART	TYPE
MAX5388EVMINIQU+	EV System

+Denotes lead(Pb)-free and RoHS compliant.

Component Lists

MAX5388 EV System (MAX5388EVMINIQU+)

PART	QTY	DESCRIPTION
MAX5388EVKIT+	1	EV kit
MINIQU+	1	Maxim command module

MAX5388 EV Kit (MAX5388EVKIT+)

DESIGNATION	QTY	DESCRIPTION
C1, C2, C3, C7, C10, C11, C14, C15, C19, C20, C23, C24, C25	13	1 μ F \pm 10%, 16V X5R ceramic capacitors (0603) Murata GRM188R71C105K or TDK C1608X5R1C105K
C4, C8, C12, C16	4	0.1 μ F \pm 10%, 50V X7R ceramic capacitors (0603) Murata GRM188R71H104K or TDK C1608X7R1H104K
C5, C6, C9, C13	0	Not installed, ceramic capacitors (0603)
C26	1	10 μ F \pm 10%, 6.3V X5R ceramic capacitor (0805) Murata GRM21BR60J106K or TDK C2012X5R0J106K
J1	1	2 x 4-pin header
J2	1	2 x 8-pin header
J3	1	8-pin female receptacle



MAX5388 Evaluation System

Component Lists (continued)

MAX5388 EV Kit (MAX5388EVKIT+) (continued)

DESIGNATION	QTY	DESCRIPTION
JU1, JU3–JU6, JU8–JU18	16	2-pin headers
JU2, JU7, JU19	3	3-pin headers
JU20	1	4-pin header
R1	1	40.2kΩ ±1% resistor (0603)
R2	1	100kΩ ±1% resistor (0603)
U1	0	Not installed, digital potentiometer (16 TQFN-EP*)
U2	0	Not installed, digital potentiometer (16 TQFN-EP*)
U3	0	Not installed, digital potentiometer (14 TSSOP)
U4	1	256-tap dual digital potentiometer (10 μMAX®) Maxim MAX5388NAUB+

DESIGNATION	QTY	DESCRIPTION
U5	1	Adjustable output LDO regulator (5 SC70) Maxim MAX8512EXK+ (Top Mark: ADW)
U6	1	2.6V LDO regulator (5 SC70) Maxim MAX8511EXK26+ (Top Mark: AAW)
U7	1	Single 1.8V to 5V level translator (6 SC70)
U8	1	Dual 1.8V to 5V level translator (8 SSOP)
—	20	Shunts (JU1–JU20)
—	1	PCB: MAX5386/5388/5391/5393 EVALUATION KIT+

*EP = Exposed pad.

Component Suppliers

SUPPLIER	PHONE	WEBSITE
Murata Electronics North America, Inc.	770-436-1300	www.murata-northamerica.com
TDK Corp.	847-803-6100	www.component.tdk.com

Note: Indicate that you are using the MAX5386, MAX5388, MAX5391, or MAX5393 when contacting these component suppliers.

MAX5388 EV Kit Files

FILE	DESCRIPTION
INSTALL.EXE	Installs the EV kit files on the computer
MAX5388.EXE	Application program
FTD2XX.INF	USB driver file
UNINST.INI	Uninstalls the EV kit software
USB_Driver_Help.PDF	USB driver installation help file

μMAX is a registered trademark of Maxim Integrated Products, Inc.

MAX5388 Evaluation System

Evaluates: MAX5386/MAX5388/MAX5391/MAX5393

Quick Start

Required Equipment

- MAX5388 EV system
 - MAX5388 EV kit
 - MINIUSB+ command module (USB cable included)
- User-supplied Windows 2000, Windows XP, or Windows Vista PC with a spare USB port
- One or two multimeters

Note: In the following sections, software-related items are identified by bolding. Text in **bold** refers to items directly from the EV kit software. Text in **bold and underlined** refers to items from the Windows operating system.

Procedure

The MAX5388 EV kit is fully assembled and tested. Follow the steps below to verify board operation:

- 1) Visit www.maxim-ic.com/evkitsoftware to download the latest version of the EV kit software, 5388Rxx.ZIP. Save the EV kit software to a temporary folder and uncompress the ZIP file.
- 2) Install the EV kit software on the computer by running the INSTALL.EXE program inside the temporary folder. The program files are copied and icons are created in the Windows **Start | Programs** menu.
- 3) Verify that shunts are correctly installed on the jumpers listed in Table 1 for proper operation of the EV kit.
- 4) Connect the multimeters to measure resistance across the MAX5388's (U4) WA and LA PCB pads and voltage across the WB and LB PCB pads.
- 5) Connect the MINIUSB+ interface board to the EV kit J2 and J3 connectors.
- 6) Connect the included USB cable from the PC to the MINIUSB+ interface board. A **Building Driver Database** window pops up in addition to a **New Hardware Found** message when installing the USB driver for the first time. If a window similar to the one described above is not seen after 30s, remove the USB cable from the board and reconnect it. Administrator privileges are required to install the USB device driver on Windows 2000, Windows XP, and Windows Vista.
- 7) Follow the directions of the **Add New Hardware Wizard** to install the USB device driver. Choose the **Search for the best driver for your device** option. Specify the location of the device driver to be **C:\Program Files\MAX5388** (default installation directory) using the **Browse** button. During device driver installation, Windows may show a warning message indicating that the device driver Maxim uses does not contain a digital signature. This is not an error condition and it is safe to proceed with installation. Refer to the USB_Driver_Help.PDF document included with the software if you have problems during this step.
- 8) Start the EV kit software by opening its icon in the **Start | Programs** menu.
- 9) Observe as the program automatically detects the USB connection and starts the main program.
- 10) Using the **Device Connected** combo box, select MAX5388 from the list and then press the **Default** button. The EV kit software main window appears, as shown in Figure 1.
- 11) The EV kit is now ready for additional testing.

Table 1. Jumper Configuration

JUMPER	SHUNT POSITION	EV KIT FUNCTION
JU16	Not installed	MAX5388 LA disconnected from GND
	Installed*	MAX5388 LA connected to GND
JU17	Not installed	MAX5388 HB disconnected from the U4 VDD voltage source
	Installed*	MAX5388 HB connected to the U4 VDD voltage source
JU18	Not installed	MAX5388 LB disconnected from GND
	Installed*	MAX5388 LB connected to GND
JU20	1-2	VPOWER = 5V
	1-3*	VPOWER = 3.3V
	1-4	VPOWER = 2.6V

*Default position.

MAX5388 Evaluation System

Detailed Description of Software

Graphical User Interface (GUI) Panel

The MAX5388 EV kit software GUI shown in Figure 1 is a Windows program that provides a convenient means to control the MAX5388 dual potentiometer. Use the mouse or press the Tab key to navigate through the GUI controls. The correct SPI write operations are generated to update the MAX5388 internal memory registers when any of these controls are executed.

The software divides the EV kit functions into group boxes. The **Interface** group box indicates the EV kit **Status** and the last write operation **Command Sent** and **Data Sent** indicators. This data confirms proper device operation. The **Device Connected** combo box selects the Maxim part being evaluated and enables the **Update Pot A and B** checkbox function when choosing the MAX5391 or MAX5393 option from the

list. The **Default** button programs both potentiometers to their midscale positions. The lower **Potentiometer A** and **Potentiometer B** group boxes provide controls to change the respective wiper positions. The main window's bottom-left status bar provides the USB interface circuit communication status.

The EV kit software can also be used to evaluate the MAX5386, MAX5388L, MAX5388M, MAX5391, and MAX5393.

Software Startup

Upon startup, the EV kit software automatically searches for the USB interface board's circuit connection. In the **Interface** group box, the **Device Connected** combo box allows the user to select the proper part being evaluated. Upon selection of the device being evaluated, the **Update Pot A and B** checkbox is enabled/disabled. The EV kit enters the normal operating mode when the USB

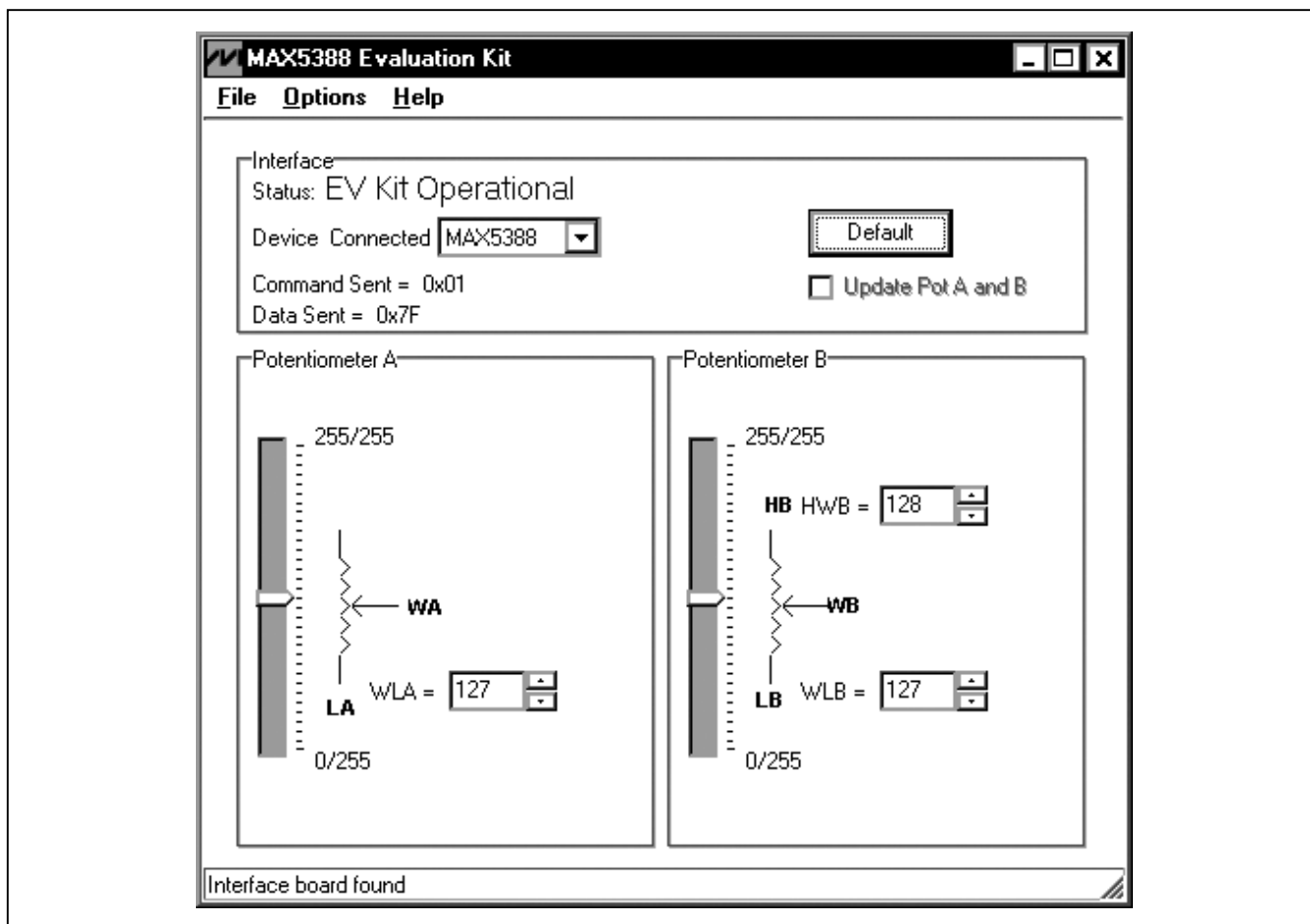

Figure 1. MAX5388 Evaluation Kit Software Main Window

MAX5388 Evaluation System

connection is detected and the part has been selected. Since the MAX5388 does not have read capability, all the edit boxes are set to question marks (??) and the **Potentiometer_** track bar is set to midscale. If the USB connection is not detected, the software prompts the user to retry, exit the program, or enter the demo mode.

Demo Mode

The EV kit software enters the demo mode—when the USB connection is not detected—by selecting **Cancel** on the **MAX5388 Evaluation Kit Interface Circuit** popup window (Figure 2). The software can also enter demo mode at any time from the main window by selecting the **Options | Demo Mode** menu item. When in demo mode, all software communication to the EV kit circuit is disabled; however, most of the software GUI is functional. Demo mode allows the user to evaluate the software without hardware connectivity. To exit demo mode, deselect the **Options | Demo Mode** menu item.

Potentiometer A and B Wiper Positions

The wiper position track bars (WA, WB) in the **Potentiometer A** and **Potentiometer B** group boxes are used to change the wiper position between the H_ and L_ end points. Use the computer mouse or arrow keys to move the wiper position between the 256 position points. The wiper position can also be changed by entering the desired integer value in the edit boxes, or by pressing the up or down arrows in the respective edit box. A change in the **W_** wiper position track bars, or **HW_/WL_** edit boxes, writes to the volatile memory

and the wiper position is updated with the data sent. The wiper position is shown in the **HW_** and **WL_** edit boxes. The **HW_** edit box shows the wiper position with respect to the potentiometer H_ end point and the **WL_** edit box shows the wiper position with respect to the potentiometer L_ end point.

Factory Default

Pressing the **Default** button resets the potentiometer A and B wiper positions to the factory-default midscale position.

Status Indicator

The **Status** indicator in the **Interface** group box displays **EV Kit Operational** when the EV kit enters the normal operating mode after the USB connection is detected. If the USB connection is not detected, or when the software enters the demo mode, the **Status** indicator displays **Demo Mode**. Demo mode is used to exercise the software without hardware connectivity.

Command Sent Indicator

The **Command Sent** indicator in the **Interface** group box displays the last command sent from the master (software) to the MAX5388. There are two commands available in the MAX5388 IC. Table 2 describes the two MAX5388 commands.

Data Sent Indicator

The **Data Sent** indicator in the **Interface** group box displays the last data sent from the master (software) to the MAX5388. The **Data Sent** indicator displays the last data

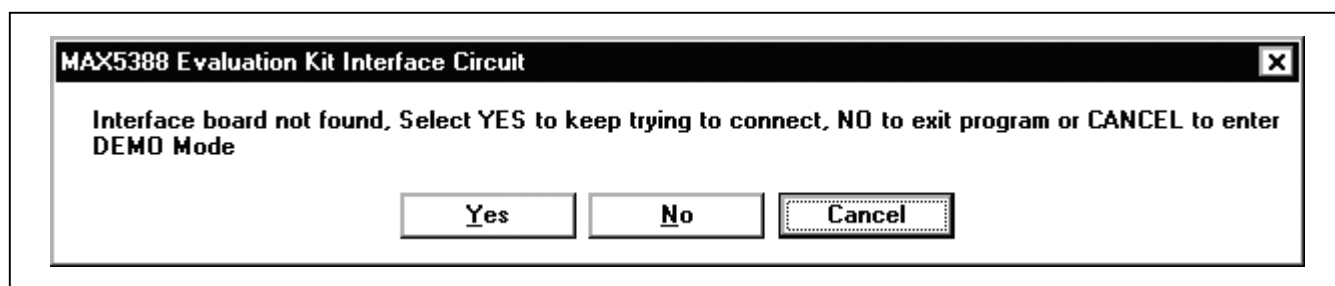

Figure 2. MAX5388 Evaluation Kit Interface Circuit Popup Window (Interface Board Not Found)

Table 2. MAX5388 SPI Command

MAX5388 REGISTER	COMMAND		DESCRIPTION
	BINARY	HEX	
VREGA	00000000	0x00	SPI data is written to potentiometer A. Wiper WA position updates with SPI data.
VREGB	00000001	0x01	SPI data is written to potentiometer B. Wiper WB position updates with SPI data.

Evaluates: MAX5386/MAX5388/MAX5391/MAX5393

MAX5388 Evaluation System

sent for the write to potentiometer A (0x00) or potentiometer B (0x01) commands.

The MAX5388 IC uses an 8-bit (MSBs, D7–D0) data byte to set the wiper position. Refer to the MAX5386/MAX5388 IC data sheet for additional information.

Keyboard Navigation

Press the Tab key to select each GUI control. The selected control is indicated by a dotted outline. Using Shift + Tab moves the selection to the previously selected control. Buttons respond to the keyboard's space bar and some controls respond to the keyboard's up and down arrow keys. Activate the program's menu bar by pressing the F10 key and then press the letter of the desired menu item. Most menu items have one letter underlined, indicating their shortcut key.

When a number is entered into the edit boxes, it can be sent to the device by pressing the Enter key. It is also sent when Tab or Shift + Tab is pressed.

Simple SPI Commands

There are two methods for communicating with the EV kit, through the normal user-interface panel (Figure 1) or through the advanced user interface available by selecting the **3-Wire Interface** (Figure 3) utility from the main program's **Options | Advanced User Interface** menu bar. A window is displayed that allows SPI send/receive data operations.

On the **3-wire interface** tab, the **Connection** group box defines the hardware connections of the interface. For the EV kit, **K10** is selected from the **Clock (SCK)(SCLK)** drop-down list, **K12** from the **Data from master to slave (MOSI)(DIN)** drop-down list is disabled, **K11** from the **Data from slave to master (MISO)(DOUT)** drop-down list, **K9** from the **Chip-select (CS) for data framing** drop-down list, and **Use standard connections for high-speed SPI** checkbox is checked (see Figure 3).

The **Configuration** group box allows the user to configure the logic level and data rate. For the EV kit, check

the **Send & Receive MSB first** checkbox and verify that the **CPOL=1(clock idle high)** and **CPHA=1(sample 2nd edge)** checkboxes are unchecked (see Figure 3).

The **Send and Receive Data** group box allows the user to send data to the MAX5388. The **Data bytes to be written** edit box indicates data to be sent from the master (microcontroller) to the device (MAX5388). Eight-bit hexadecimal numbers should be comma delimited. Press the **Send Now** button to transmit the data from the master to the device. Data appearing in the **Data bytes received** edit box is data read from the device. The **Data bytes received** edit box in the EV kit software always shows a default value of **0xFF** since the MAX5388 does not send data back to the master.

Note: The SPI dialog boxes accept numeric data in hexadecimal format. Hexadecimal numbers must be prefixed by \$ or 0x. Figure 3 shows a simple SPI write-byte operation using the included 3-wire interface diagnostics tool. In this example, the software is sending command 0x01 (write to potentiometer B) and data 0x7F. The data sequence sets the MAX5388 wiper position to 127.

General Troubleshooting

Problem: Software reports it cannot find the interface circuit.

- Is the USB cable connected to the MINIQUSB+ board?
- Has Windows plug-and-play detected the board? Bring up **Control Panel->System->Device Manager**, and look at what device nodes are indicated for USB. If there is an **Unknown device node** attached to the USB, uninstall it—this forces plug-and-play to try again.
- If using an off-board SPI interface, is the power ground connected to the EV kit ground (GND) at one of the header J1 pin connections (J1-2, J1-4, J1-6, or J1-8)?

MAX5388 Evaluation System

Evaluates: MAX5386/MAX5388/MAX5391/MAX5393

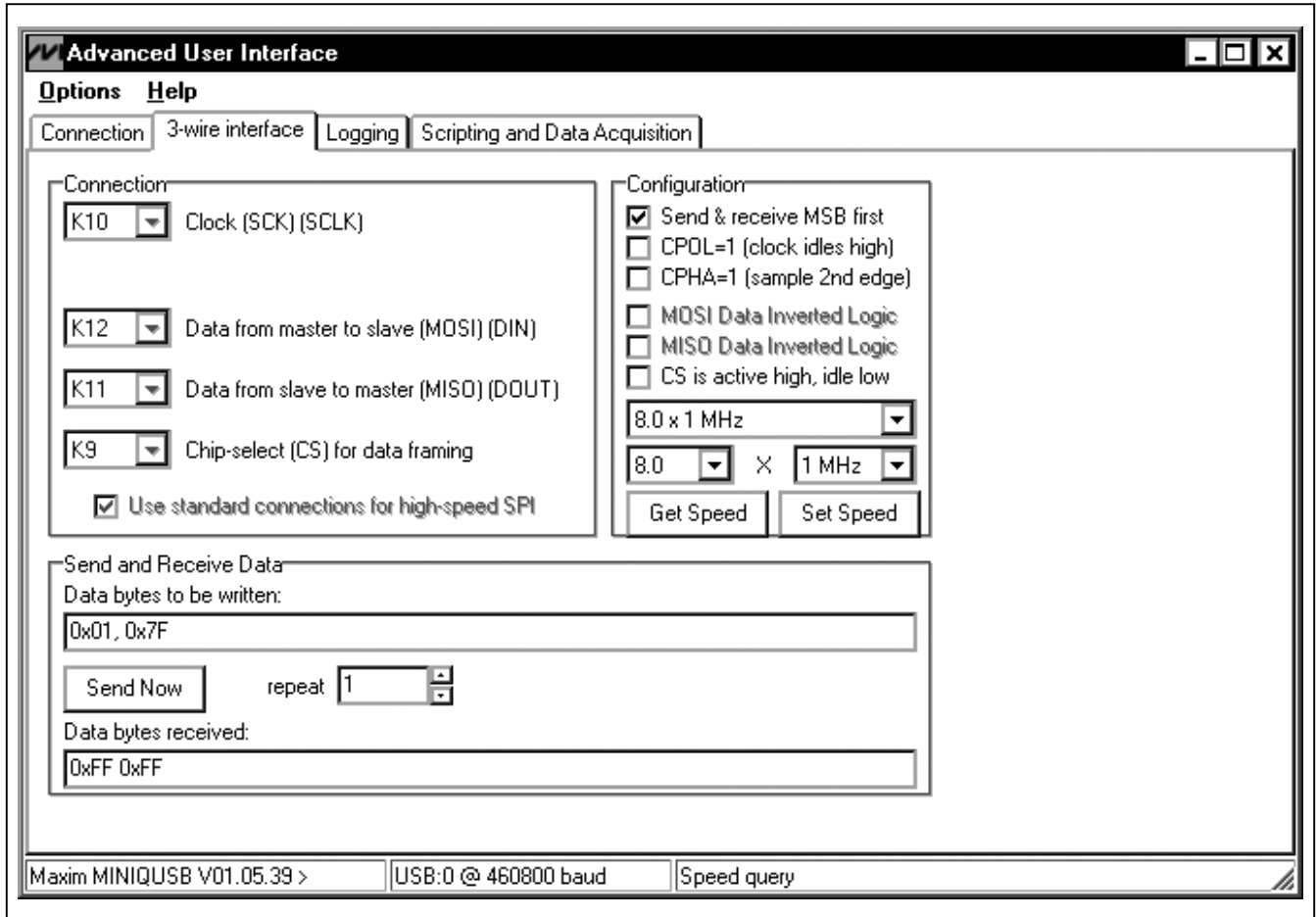

Figure 3. Simple Low-Level 3-Wire Interface

MAX5388 Evaluation System

Detailed Description of Hardware

The MAX5388 EV kit is an assembled and tested PCB that features the MAX5388N 100kΩ dual digital potentiometers. Both potentiometer A and B have an end-to-end resistance of 100kΩ and each wiper can be programmed independently among 256 tap positions. The MAX5388 IC consists of one digital potentiometer in a variable-resistor configuration and one digital potentiometer in a voltage-divider configuration. The EV kit uses a MAX5388N IC in a 10 μMAX package on a proven two-layer PCB design.

The EV kit provides connector J1 to interface with the MAX5388 CS, DIN, SCLK, and GND signals directly to a user-supplied 3-wire system. Connector J1 also provides a connection for the EV kit's 2.6V to 5.5V VPOWER power-supply input.

The EV kit is typically used with a MINIUSB+ interface board for communicating with a PC through the 3-wire serial interface. Logic-level translators U7 and U8 provide proper SPI interface translation when using 2.6V to 5.5V to power the MAX5388 VDD input.

MAX5388 VDD Input Source

The VPOWER rail is typically supplied as 3.3V or 5V by the MINIUSB+ interface board circuitry, or 2.6V using LDO regulator U6. The VPOWER rail sets the MAX5388 VDD input to 5V, 3.3V, or 2.6V. See Table 3 for proper jumper configurations for setting the MAX5388 VDD input.

Table 3. VPOWER Rail (JU20)

SHUNT POSITION	VPOWER RAIL	MAX5388 VDD INPUT
1-2	5V (MINIUSB+ circuitry)	5V
1-3*	3.3V (MINIUSB+ circuitry)	3.3V
1-4	2.6V (LDO U6)	2.6V
Not installed	External source applied at EV kit VDD and GND PCB pads	External source applied at EV kit VDD and GND PCB pads

*Default position.

Note: The MAX5388 VDD input has a minimum 2.6V requirement.

Table 4. Header J1 Pin Assignments

PIN	SIGNAL
J1-1	VPOWER
J1-2, J1-4, J1-6, J1-8	GND
J1-3	CS
J1-5	DIN
J1-7	SCLK

SPI Clock and Data-/Chip-Select Inputs

The MAX5388 features a clock and data-/chip-select input pins for SPI-compatible communication to control the MAX5388 wiper position. The clock, data-, and chip-select pins can be driven by the MINIUSB+ interface circuit or the PCB header (J1), along with a user-supplied external SPI-compatible controller. An external SPI-compatible controller can be connected to CS (J1-3), DIN (J1-5), SCLK (J1-7), and GND (J1-2) on header J1 to communicate with the MAX5388 IC. When using an external SPI-compatible controller, verify that the MINIUSB+ interface board has been disconnected from the EV kit's J2 and J3 headers. See Table 4 for header J1 pin assignment.

Potentiometer, Variable Resistor with Ground Reference (Potentiometer A)

The MAX5388 IC potentiometer A is internally configured as a variable resistor. The EV kit allows potentiometer A to be configured with ground reference by shorting LA to ground. Table 5 lists jumper options for configuring potentiometer A.

Verify that any power source connected to the WA or LA pads are voltage and current limited to the maximum conditions stated in the MAX5386/MAX5388 IC data sheet.

Potentiometer, Voltage-Divider or Variable Resistor, with Ground Reference (Potentiometer B)

The EV kit provides an option to configure the MAX5388 potentiometer B as a potentiometer or voltage-divider,

Table 5. JU16 Jumper Function (Potentiometer A)

SHUNT POSITION	LA PAD	MAX5388 FUNCTION
Not installed	Not connected	Potentiometer without GND reference
Installed*	Connected to GND	Potentiometer with GND reference

MAX5388 Evaluation System

open ended or with ground reference, respectively. Use jumpers JU17 and JU18 for potentiometer B configurations. Table 6 lists jumper options for configuring potentiometer B.

Potentiometer B can also be configured as a variable resistor by shorting the HB and WB pads using a wire. When operating as a variable resistor, any power source connected to the HB, WB, or LB pads must be voltage and current limited to the maximum conditions stated in the MAX5386/MAX5388 IC data sheet.

Note: To test the device in resistor mode, the ohmmeter must be GND referenced to the MAX5388. This can be accomplished by connecting the L_ pin to GND or the H_ pin to VDD. Resistance can then be measured between W_ and L_ or W_ and H_ PCB pads.

Evaluating the MAX5386, MAX5391, and MAX5393 ICs

The EV kit is populated with additional PCB footprints (U1, U2, and U3) and various jumpers to evaluate the MAX5386, MAX5391, and MAX5393, respectively.

Jumper JU1 and LDO U5 are available to use as a 1.7V power source when evaluating the MAX5391 and MAX5393 EV kits. Refer to the MAX5386M, MAX5391L, MAX5391N, or MAX5393 evaluation system data sheets for additional information when evaluating the MAX5386, MAX5391, or MAX5393 digital potentiometers.

Table 6. JU17 and JU18 Jumper Functions (Potentiometer B)

SHUNT POSITION		HB PAD	LB PAD	MAX5388 FUNCTION
JU17	JU18			
Not installed	Not installed	Not connected	Not connected	Potentiometer open ended
	Installed		Connected to GND	Potentiometer with GND reference
Installed*	Not installed	Connected to VDD	Not connected	Voltage-divider open ended
	Installed*		Connected to GND	Voltage-divider with GND reference

*Default position.

Table 7. Jumper Configuration (JU1–JU20)

JUMPER	SHUNT POSITION	EV KIT FUNCTION
JU1	Not installed*	1.7V LDO output disabled
	Installed	1.7V LDO output enabled
JU2	1-2*	MAX5386 VDD voltage not powered
	2-3	MAX5386 VDD voltage dependent on jumper JU20 configuration
JU3	Not installed	MAX5386 HA disconnected from the U1 VDD voltage source
	Installed*	MAX5386 HA connected to the U1 VDD voltage source
JU4	Not installed	MAX5386 LA disconnected from GND
	Installed*	MAX5386 LA connected to GND
JU5	Not installed	MAX5386 HB disconnected from the U1 VDD voltage source
	Installed*	MAX5386 HB connected to the U1 VDD voltage source
JU6	Not installed	MAX5386 LB disconnected from GND
	Installed*	MAX5386 LB connected to GND
JU7	1-2*	MAX5391 VDD voltage not powered
	2-3	MAX5391 VDD voltage dependent on jumper JU20 configuration
JU8	Not installed	MAX5391 HA disconnected from the U2 VDD voltage source
	Installed*	MAX5391 HA connected to the U2 VDD voltage source
JU9	Not installed	MAX5391 LA disconnected from GND
	Installed*	MAX5391 LA connected to GND

Evaluates: MAX5386/MAX5388/MAX5391/MAX5393

MAX5388 Evaluation System

Table 7. Jumper Configuration (JU1–JU20) (continued)

JUMPER	SHUNT POSITION	EV KIT FUNCTION
JU10	Not installed	MAX5391 HB disconnected from the U2 VDD voltage source
	Installed*	MAX5391 HB connected to the U2 VDD voltage source
JU11	Not installed	MAX5391 LB disconnected from GND
	Installed*	MAX5391 LB connected to GND
JU12	Not installed	MAX5393 HA disconnected from the U3 VDD voltage source
	Installed*	MAX5393 HA connected to the U3 VDD voltage source
JU13	Not installed	MAX5393 LA disconnected from GND
	Installed*	MAX5393 LA connected to GND
JU14	Not installed	MAX5393 HB disconnected from the U3 VDD voltage source
	Installed*	MAX5393 HB connected to the U3 VDD voltage source
JU15	Not installed	MAX5393 LB disconnected from GND
	Installed*	MAX5393 LB connected to GND
JU16	Not installed	MAX5388 LA disconnected from GND
	Installed*	MAX5388 LA connected to GND
JU17	Not installed	MAX5388 HB disconnected from the U4 VDD voltage source
	Installed*	MAX5388 HB connected to the U4 VDD voltage source
JU18	Not installed	MAX5388 LB disconnected from GND
	Installed*	MAX5388 LB connected to GND
JU19	1-2*	MAX5393 VDD not powered
	2-3	MAX5393 VDD voltage dependent on jumper JU20 configuration
JU20	1-2	VPOWER = 5V
	1-3*	VPOWER = 3.3V
	1-4	VPOWER = 2.6V

*Default position.

MAX5388 Evaluation System

Evaluates: MAX5386/MAX5388/MAX5391/MAX5393

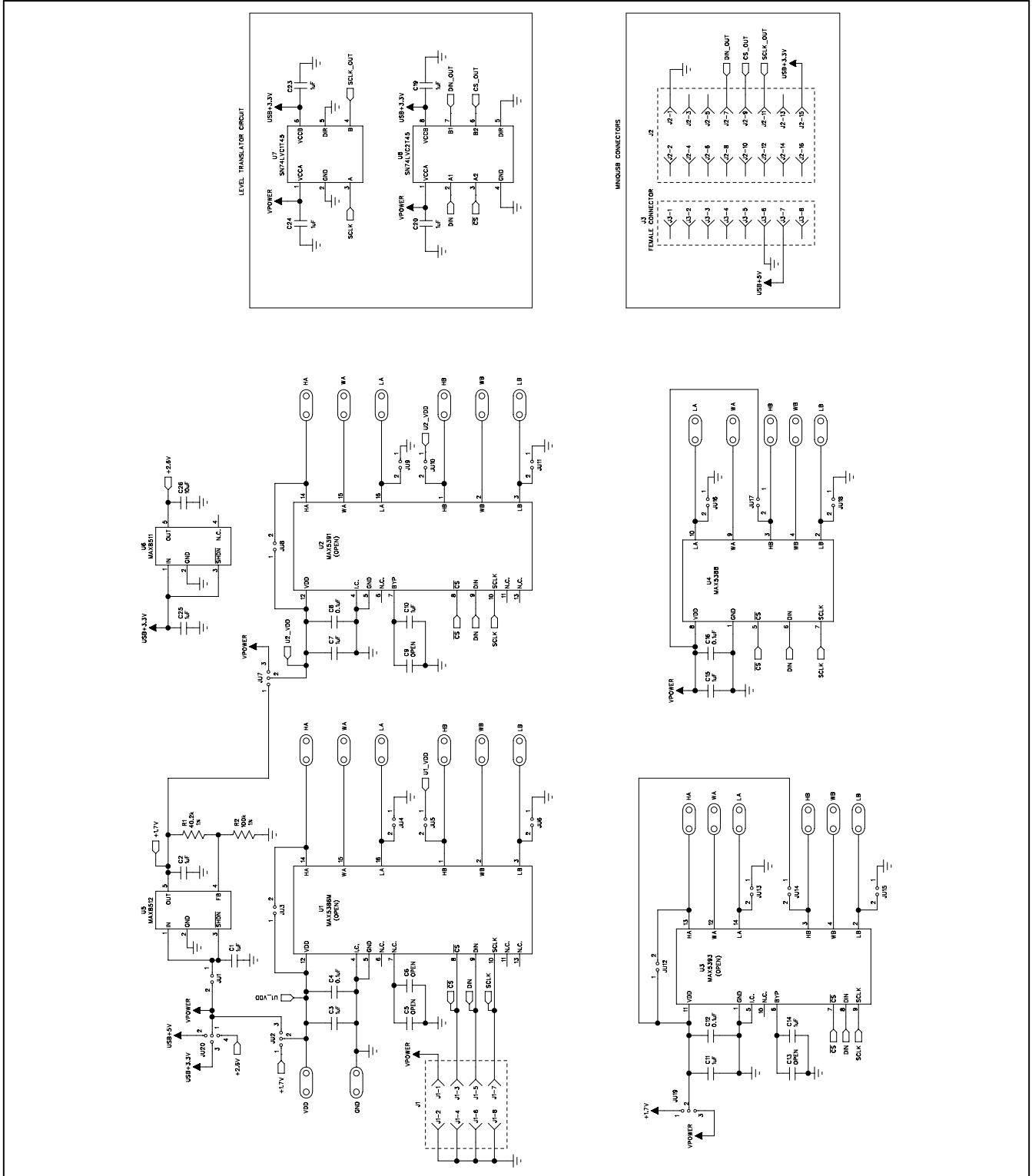

Figure 4. MAX5388 EV Kit Schematic

MAX5388 Evaluation System

Evaluates: MAX5386/MAX5388/MAX5391/MAX5393

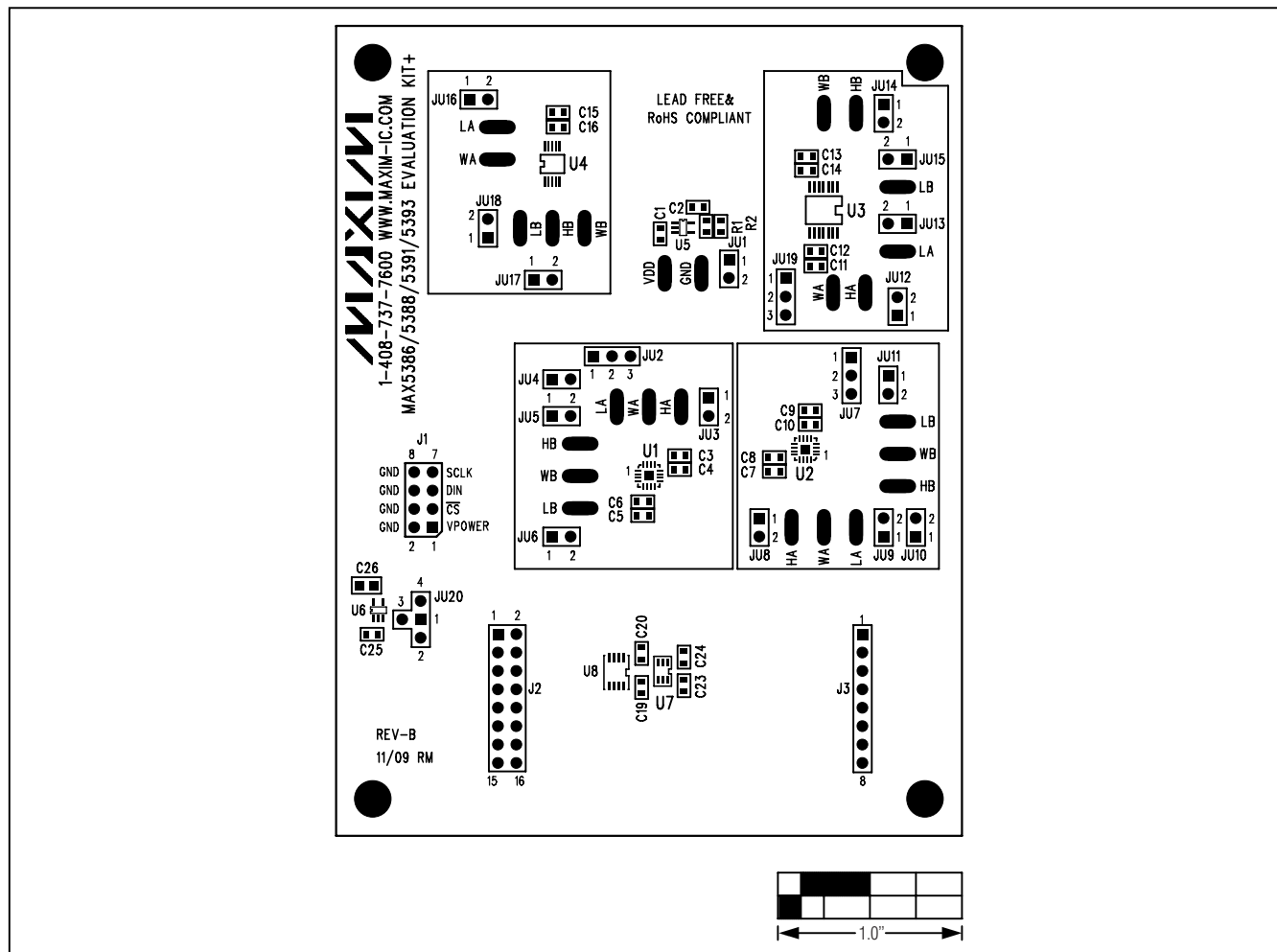

Figure 5. MAX5388 EV Kit Component Placement Guide—Component Side

MAX5388 Evaluation System

Evaluates: MAX5386/MAX5388/MAX5391/MAX5393

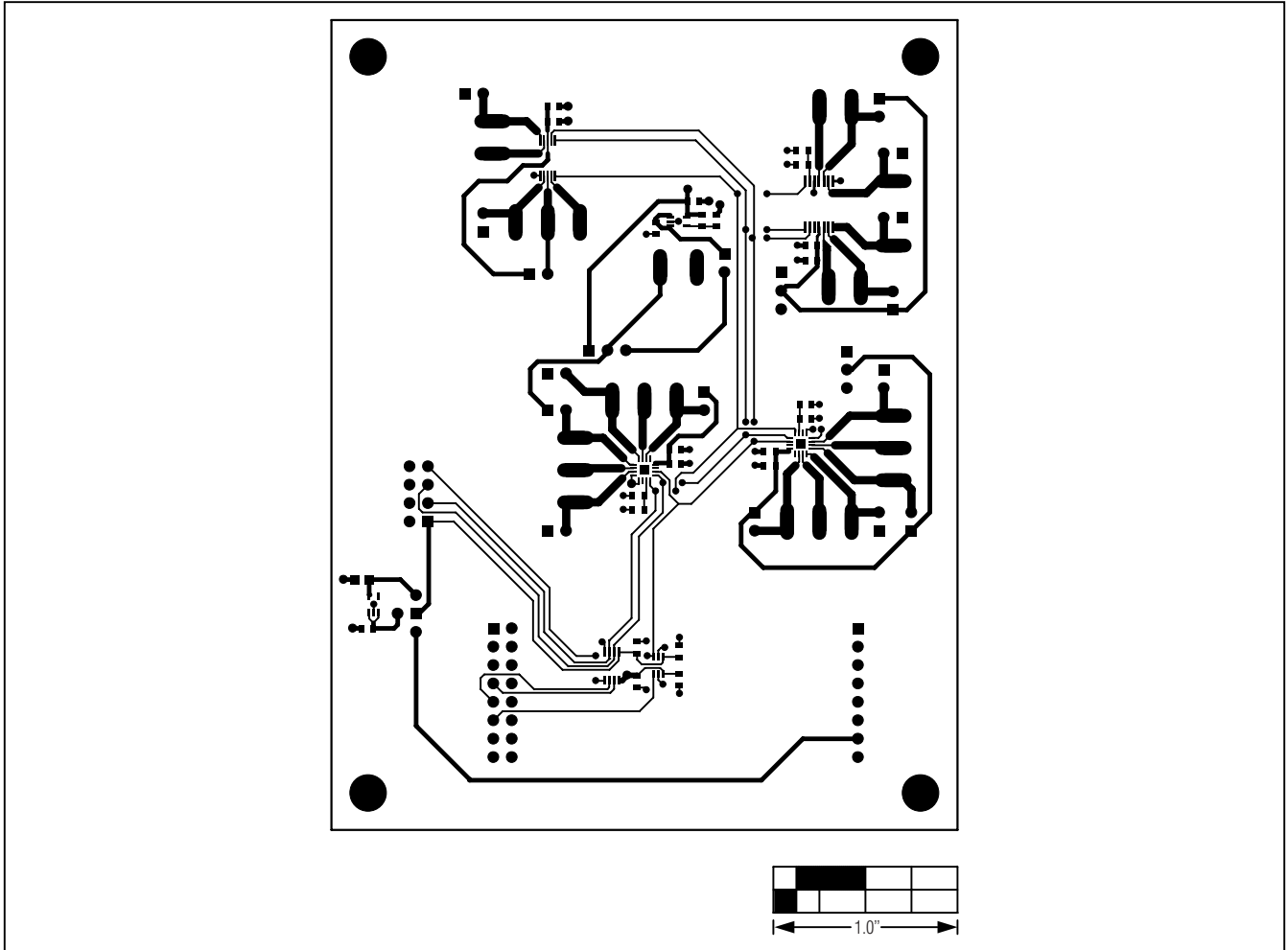

Figure 6. MAX5388 EV Kit PCB Layout—Component Side

MAX5388 Evaluation System

Evaluates: MAX5386/MAX5388/MAX5391/MAX5393

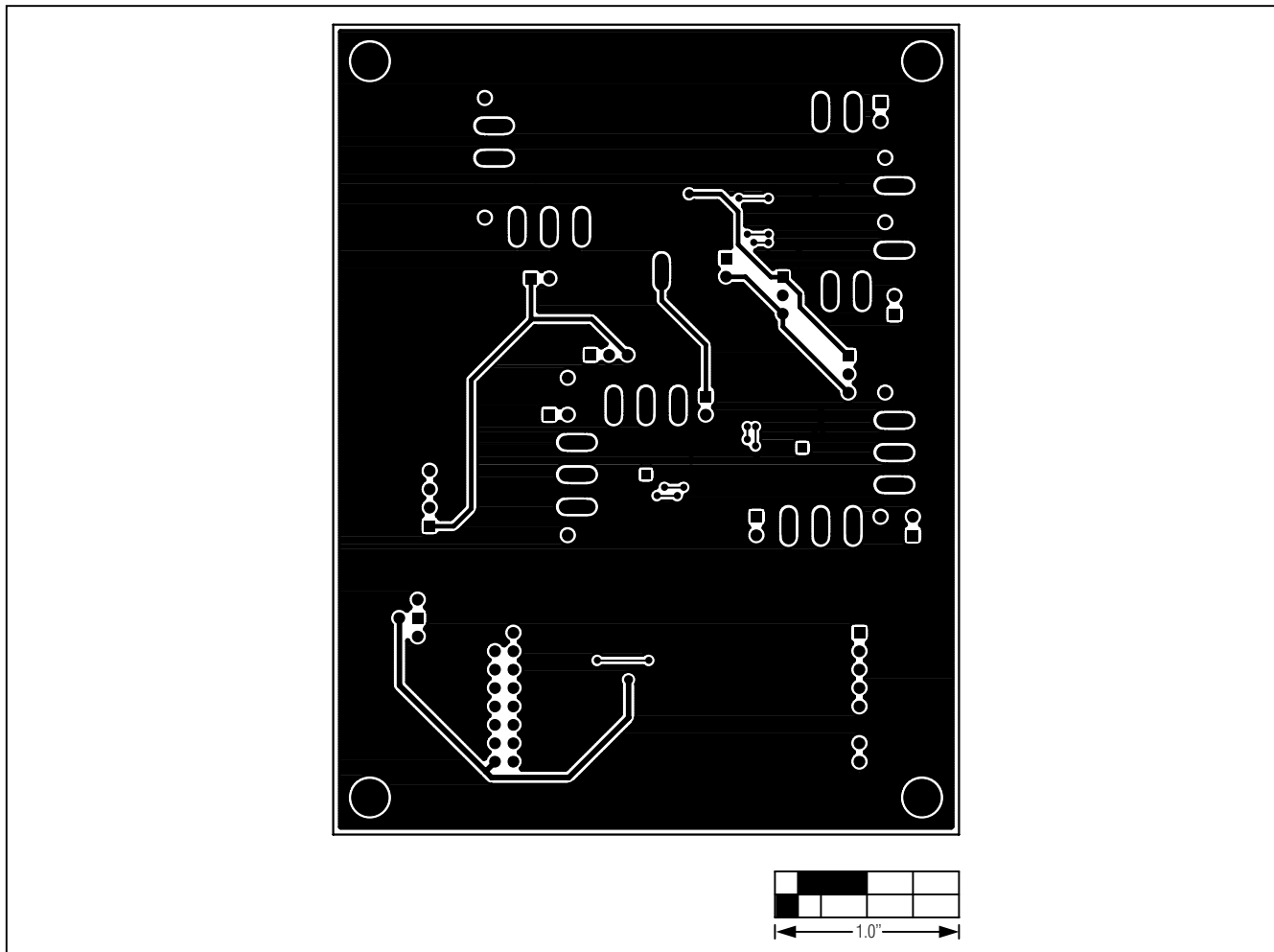

Figure 7. MAX5388 EV Kit PCB Layout—Solder Side

Maxim cannot assume responsibility for use of any circuitry other than circuitry entirely embodied in a Maxim product. No circuit patent licenses are implied. Maxim reserves the right to change the circuitry and specifications without notice at any time.

14 **Maxim Integrated Products, 120 San Gabriel Drive, Sunnyvale, CA 94086 408-737-7600**

© 2010 Maxim Integrated Products

Maxim is a registered trademark of Maxim Integrated Products, Inc.