

THIS DRAWING IS UNPUBLISHED. RELEASED FOR PUBLICATION 20
 © COPYRIGHT 20 BY - ALL RIGHTS RESERVED.

| REVISIONS | | | | | |
|-----------|-----|----------------------------------|-----------|-----|------|
| P | LTR | DESCRIPTION | DATE | DWN | APVD |
| A1 | | INCREASE WIPE LENGTH LIMIT | 30NOV2022 | AL | SH |
| A2 | | REDUCE INSERTION DEPTH | 01DEC2022 | AL | SH |
| A3 | | ADD NEW PN FOR LARGE WIPE LENGTH | 07DEC2022 | AL | SH |

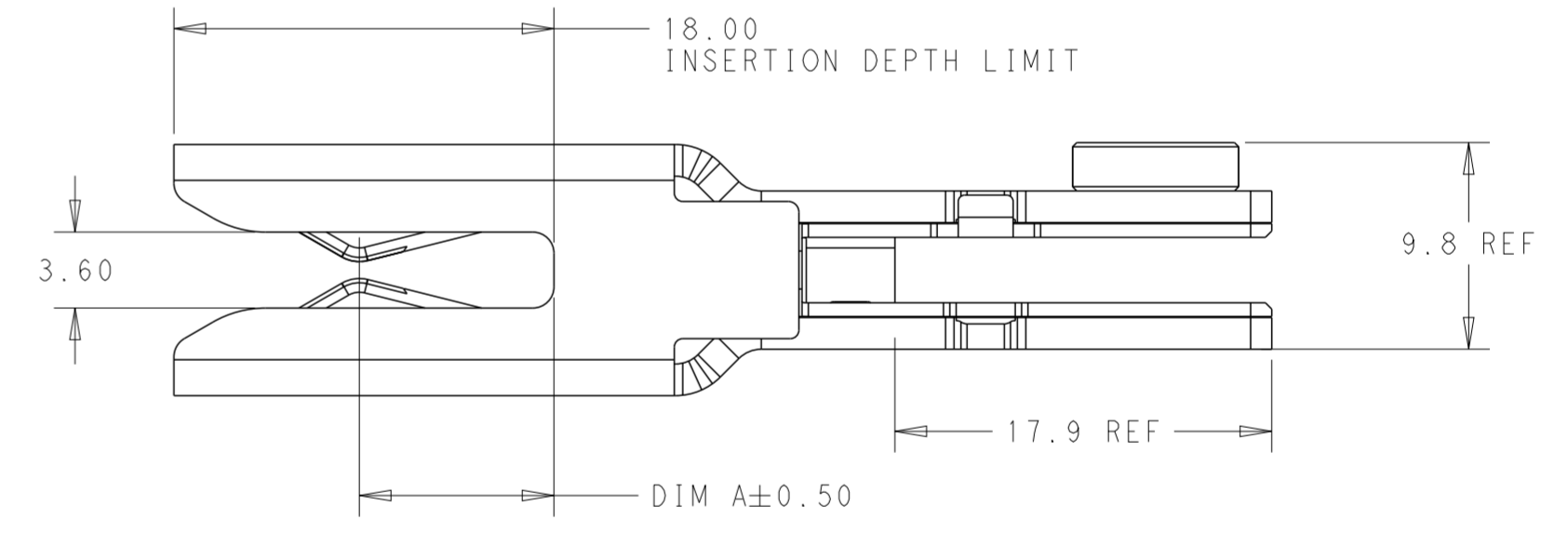
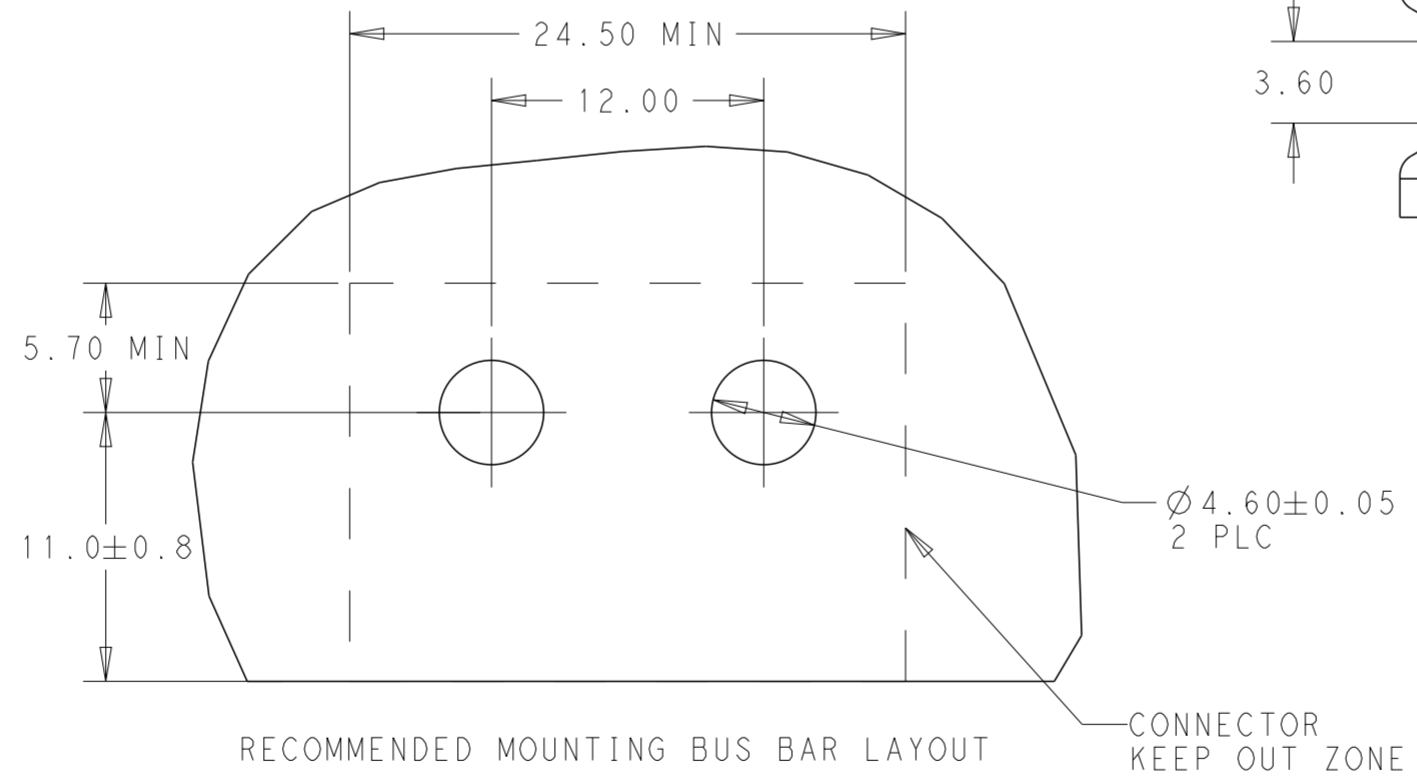
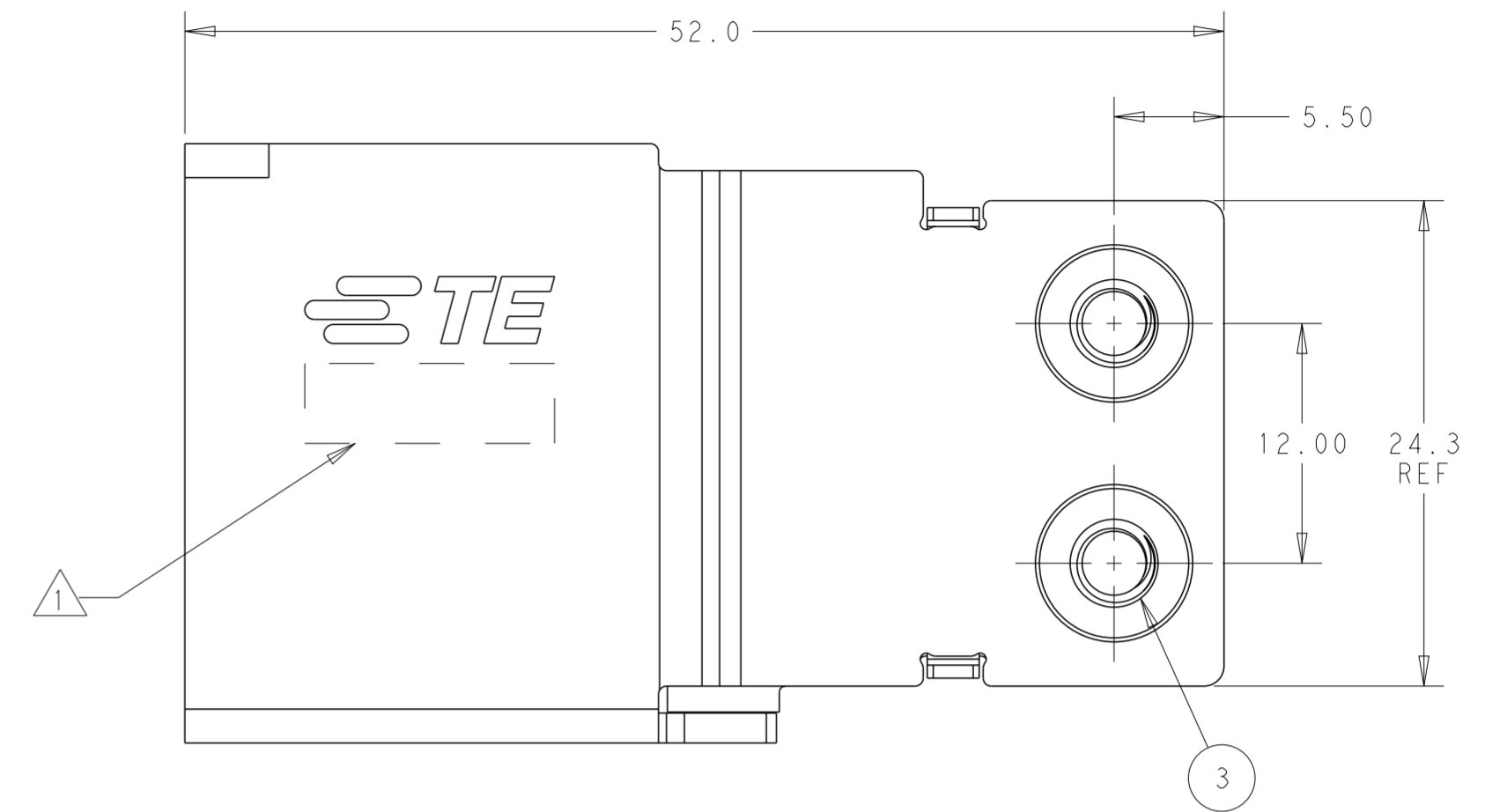
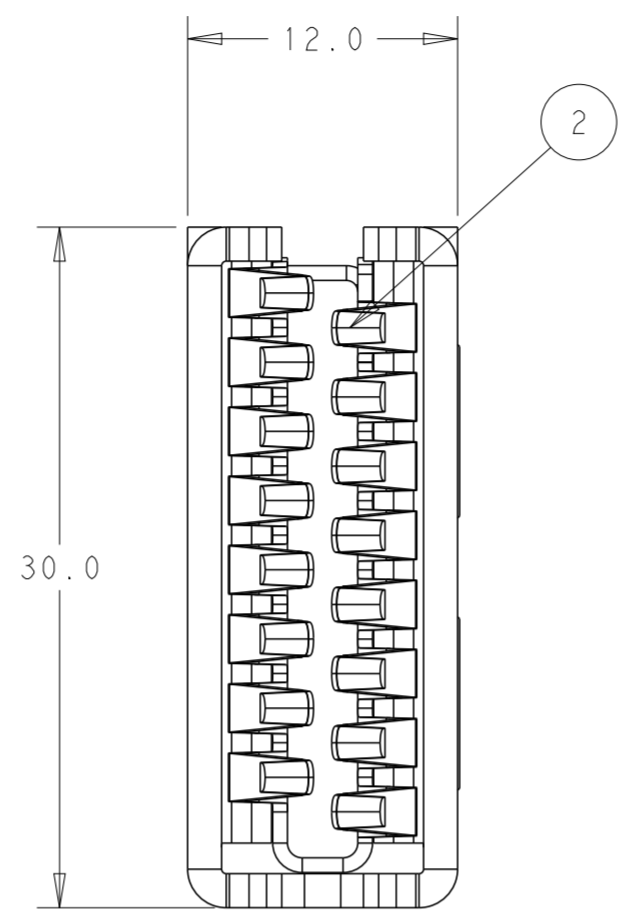
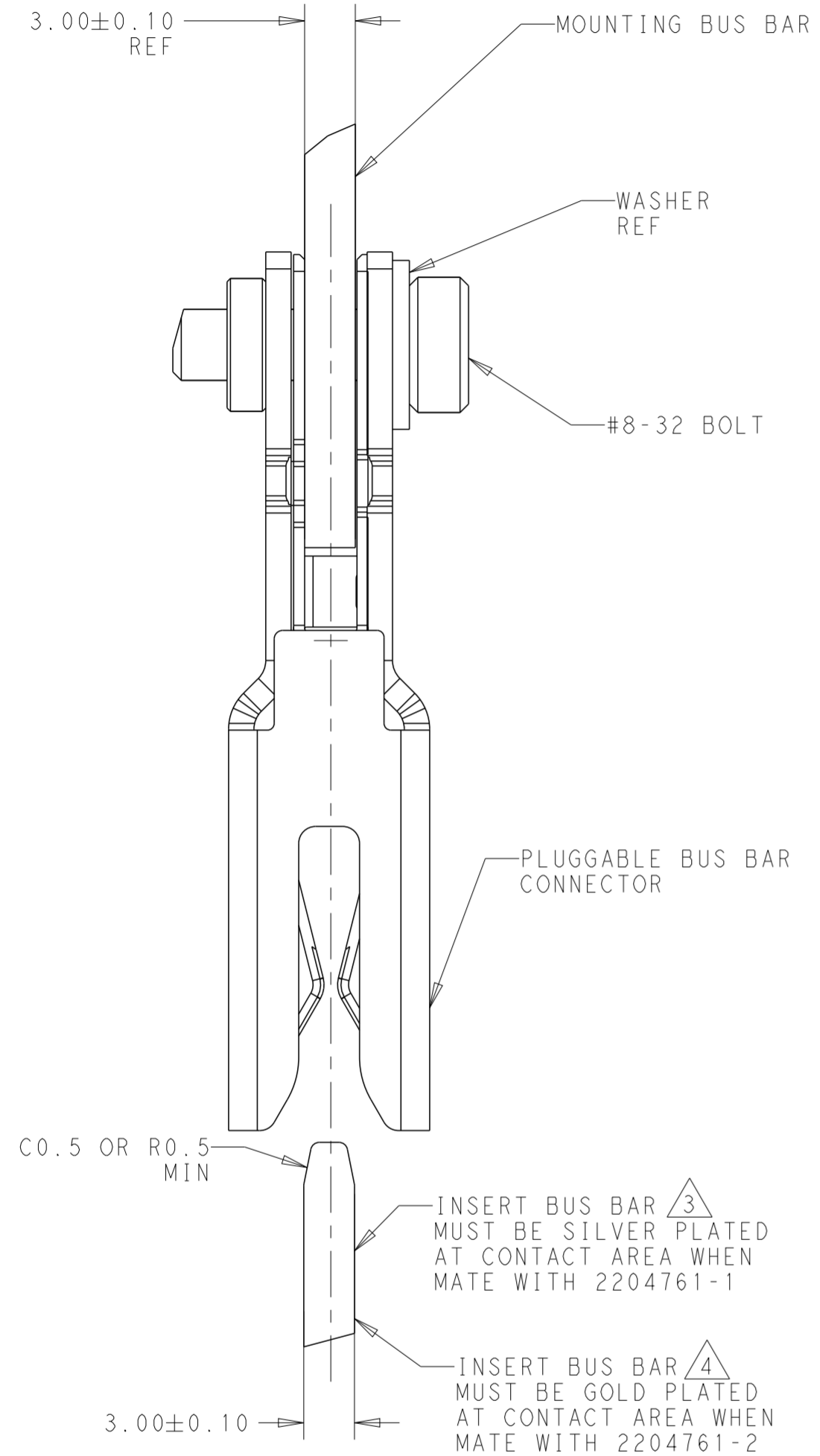

- NOTES:
- 1 PART NUMBER AND DATECODE TO BE MARKED IN AREA SHOWN
 - 2 MATERIAL: SHOWN IN BOM LIST
 - 3 BUS BAR MUST BE SILVER PLATING ON CONTACT AREA WHEN MATE WITH 2204761-1 AND 2204761-5
 - 4 BUS BAR MUST BE GOLD PLATING ON CONTACT AREA WHEN MATE WITH 2204761-2 AND 2204761-6.

| DIM A | PART NUMBER |
|-------|-------------|
| 10.92 | 2204761-6 |
| 10.92 | 2204761-5 |
| 9.22 | 2204761-2 |
| 9.22 | 2204761-1 |

| PART NUMBER | ITEMS | DESCRIPTION | MATERIAL | Q'TY | FINISH |
|-----------------------------|-------|----------------------------|-----------------|------|--------|
| 2204761-2 2204761-6 2 | 3 | CLINCHING NUT #8-32 THREAD | STAINLESS STEEL | 2 | - |
| | 2 | CONTACT | COPPER ALLOY | 1 | GOLD |
| | 1 | OUTER HOUSING | STAINLESS STEEL | 1 | - |
| 2204761-1 2204761-5 2 | 3 | CLINCHING NUT #8-32 THREAD | STAINLESS STEEL | 2 | - |
| | 2 | CONTACT | COPPER ALLOY | 1 | SILVER |
| | 1 | OUTER HOUSING | STAINLESS STEEL | 1 | - |

THIS DRAWING IS A CONTROLLED DOCUMENT.

| | | | |
|----------------|--|---------------------------|---|
| DIMENSIONS: mm | TOLERANCES UNLESS OTHERWISE SPECIFIED: | DWN ANDY LI 30JUN2016 | TE Connectivity |
| | 0 PLC ± | CHK SUNY ZHAO 30JUN2016 | |
| | 1 PLC ±0.3 | APVD SUNY ZHAO 30JUN2016 | |
| | 2 PLC ±0.2 | PRODUCT SPEC 108-128012 | |
| MATERIAL | FINISH | APVD SUNY ZHAO 30JUN2016 | NAME STAIGHT TYPE IN-LINE MOUNT PLUGGABLE BUS BAR CONNECTOR |
| | | APPLICATION SPEC 114-2130 | SIZE A2 |
| | | WEIGHT | CAGE CODE - |
| | | CUSTOMER DRAWING | DRAWING NO C-2204761 |
| | | | RESTRICTED TO - |
| | | | SCALE 2:1 |
| | | | SHEET 1 OF 1 |
| | | | REV A3 |