

Quality Control Standard

出货品质标准

Valued customer 客户名称 :	Customer Product Name/No. (客户产品名称/编号):	打印机	
Model No 机种编号 :	Swatch No.: 样品编号	Date作成日: Rev. Date修订日:	2023/2/1 Rev.
Our Code No. 仕样编号 :	(Please Use Our Code No. To Order) (订货时请用此仕样编号)	备注 DV ROHS	

1. Conditions of Standard Operation / 工作条件

1- 1)Driving Voltage 驱动电压	:	18	V DC Constant between motor terminals. 马达端子电压 18 V 直流恒压。
1- 2)Direction of Rotation 回转方向	:	CW	viewing from metal housing. 面对马达金属外壳时。
1- 3)Position of Motor 马达放置状态	:	To be placed horizontally when measuring. 测试时水平放置。	

1- 4)Operating Temperature工作温度	:	-10	°C to	60	°C	
1- 5)Operating Humidity工作湿度	:	30%RH to 95%RH				

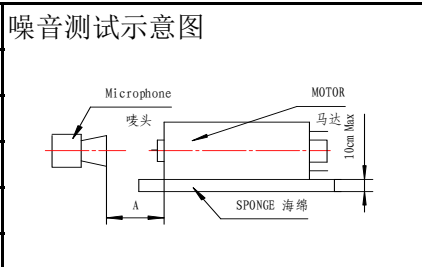

2. Conditions of Standard Test / 测试条件

2- 1)Testing Temperature测试温度	:	10°C	to	30°C	
2- 2)Testing Humidity测试湿度	:	30%RH to 95%RH			

3. Initial Electrical Characteristics / 初期特性

3- 1) No Load Speed 无负荷转速	:	7500	±	1100	rpm 转/分
3- 2) No Load Current 无负荷电流	:	45		mA max. 毫安培	
3- 3) Stall Torque 堵转扭力	At Load 在负载点	2.4 & 9.0	mNm	17.5	mNm min. mNm
		17.5			
3- 4) Stall Current 堵转电流	在负载点	2.4 & 9.0	mNm	1540	mA max. 毫安培
		1540			
3- 5) Mechanical Noise(vertical from housing side 10 cm Background noise 30dB Max) 机械噪音(距离铁壳侧 10 cm, 环境噪音30dB Max)	:	47	dB Or below(RMS)JIS-A Characteristics dB 以下(RMS) JIS-A特性		
3- 6) Reference Performance Curve 参考性能曲线	:	As per attached Sheet 所附图表为		RC370-KT-15375	
3- 7) Dimensions 外形尺寸	:	As per Drawing attached 所附图面为		WG- R370T-T85	
3- 8) End play of Shaft 虚位	:	0.01	~	0.30	mm 毫米

For & on behalf of Customer

For & on behalf of Standard Motor Co., Ltd.

Jack Lee 2023/02/07



As a reminder, the specification should be signed and returned within two weeks, or it will be considered as acceptable by the customer. 如果客户两周内不签字确认并返回, 将被视为已认可此规格。

性能表只供参考
马达实际参数请以马达出货标准为主



STANDARDMOTOR 標準微型摩打有限公司

两点法: 24.5 g.cm & 91.8 g.cm

Model/Winding 型号/卷线	Voltage 电压 V	No Load 无负荷		At Maximum Efficiency 最大效率点				At Maximum Output 最大功率点				Stall 停止	
		Current 电流 A	Speed 转速 rpm	Current 电流 A	Speed 转速 rpm	Torque 扭矩 g.cm	Efficiency 效率 %	Current 电流 A	Speed 转速 rpm	Torque 扭矩 g.cm	Output 功率 W	Current 电流 A	Torque 扭矩 g.cm
RC370-KT-15375	18.0	0.032	7508	0.196	6461	34.5	64.8	0.621	3754	123.7	4.76	1.210	247.4

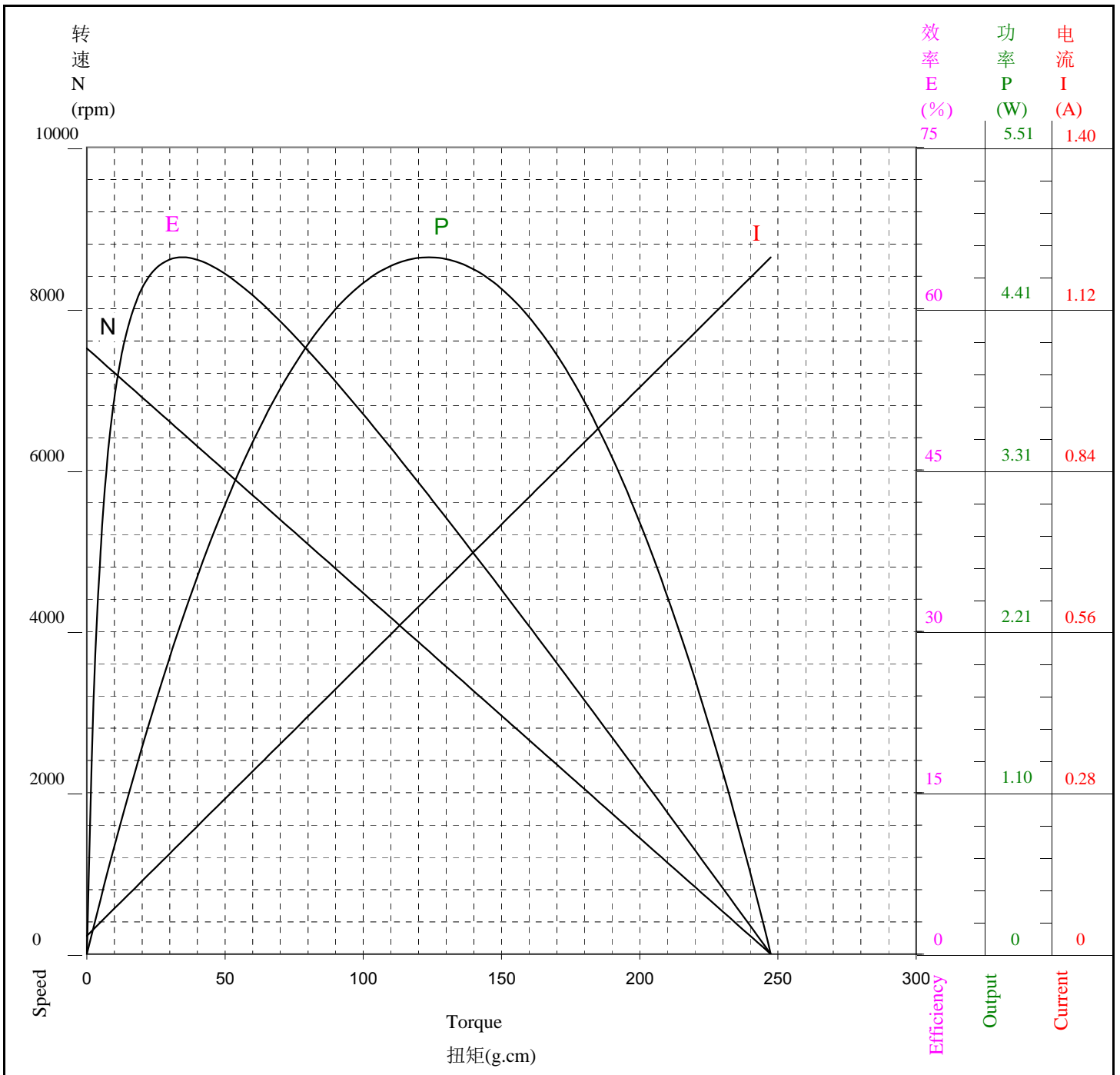

MARK	POSITION	DESCRIPTION	DATE	BY

马达回转方向
DIRECTION OF ROTATION

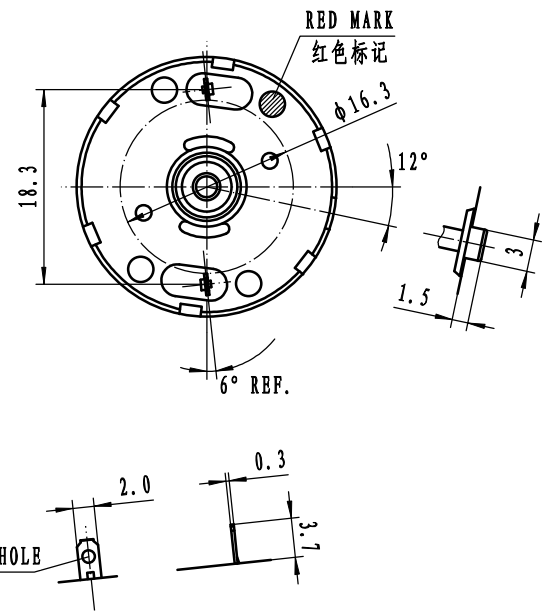
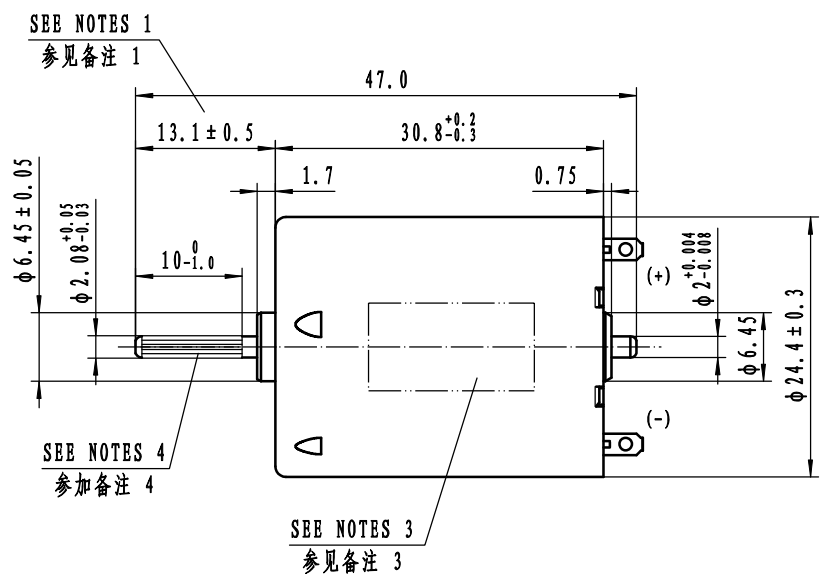
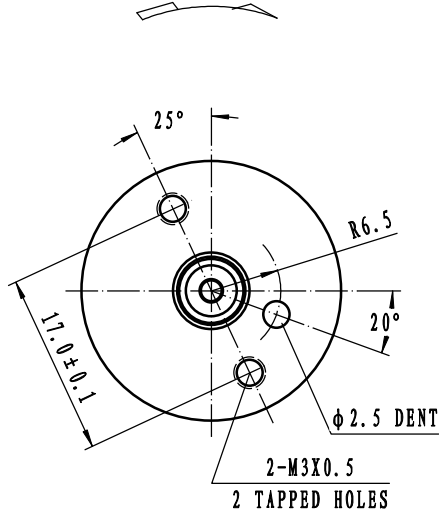

NOTES(备注):

1. THIS DIM APPLIES ONLY WHEN MOTOR SHAFT IS IN EXTREME RIGHT POSITION
该尺寸适用于将轴压于右侧时
2. SHAFT END PLAY 0.01-0.3
马达虚位(轴向串动) 0.01-0.3
3. SPECIFIED CONTENT WILL BE TYPEGRAPHICALED IN CONFORMITY TO GETUP BOOK OF MOTOR
按马达仕样书印刷指定内容
4. PLEASE SEE INCLUDED DRAWINGS FOR STRAIGHT LINE PATTERN HATCHING PROCBSS
在轴端进行直纹滚花加工
5. APPLIED SCREW LENGTH AT 2.0 MAX. MEASURED FROM THE HOUSING MOUNT SURFACE
从大壳安装面计算, 允许螺钉旋入深度2.0 MAX.

Characteristic	DWN. BY	陈家辉	DWN. DATE	23.02.07	TITLE	Motor Outline Drawing		
Cpk > 1.33	CHK. BY		CHK. DATE		DWG. No.	WG-R370T-T85		
Quality control	APP. BY		APP. DATE		Undeclared tolerance	± 0.3	Angle tolerance	± 3°
Not mark	Not required	STANDARD MOTOR CO.,LTD.			SCALE	2:1	Rev.	- A3