

PART NUMBER	REVISION	DESCRIPTION	FEED TYPE
2151482-1	D	FINE CRIMP HEIGHT ADJUST	MECHANICAL
2151482-2	E	FINE CRIMP HEIGHT ADJUST	PNEUMATIC
7-2151482-1	D	MECHANICAL AND CRIMP TOOLING KIT	MECHANICAL
7-2151482-2	E	PNEUMATIC AND CRIMP TOOLING KIT	PNEUMATIC
7-2151482-7	A	CRIMP TOOLING KIT	-

ATLANTIC VERSION TERMINATOR INTERFACE ADAPTER

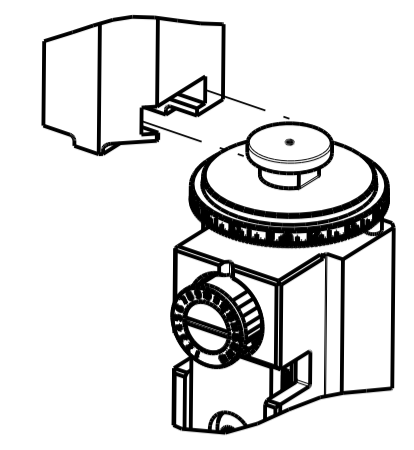

APPLICATOR DATA		
CRIMP	SIZE	TYPE
WIRE	1.40 mm [.055]	F
INSUL	1.78 mm [.070]	O

APPLICATOR INSTRUCTIONS  
408-35042

TERMINAL DATA: TE TERMINAL		TE CRIMP SPECIFICATION	
TERMINAL NAME: AMP MCP 1.5K FLAT TYPE RECEPTACLE			
WIRE STRIP LENGTH		INSULATION DIAMETER RANGE	
3.10-3.70 mm [.122-.146 IN]		Ø1.20-1.40 mm [.047-.055 IN]	
TERMINAL APPLICATION SPECIFICATION	114-18386		
TERMINALS APPLIED			
TE TERMINAL	TE TERMINAL	TE TERMINAL	TE TERMINAL
1564980-1	1564980-2	1418406-1	

WIRE SIZE	CRIMP HEIGHT mm [INCH]	CRIMP HEIGHT REFERENCE SETTING
0.35mm2	0.93+/-0.03 [.037+/- .001]	9.1
0.22mm2	0.86+/-0.03 [.034+/- .001]	10.0

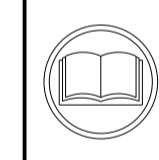

- RECOMMENDED SPARE PARTS
- REFER TO SUPPLIED INSTRUCTION SHEET FOR CLEANING, LUBRICATION AND STORAGE OF APPLICATOR.
- APPLY PART NUMBER 2-23419-6 LOCTITE TO THREADS OF ITEM 242.
- CRIMP HEIGHT REFERENCE SETTING WAS THE SETTING USED WHEN THE APPLICATOR WAS QUALIFIED AT THE FACTORY. ADJUSTMENT MAY BE NECESSARY WHEN RUNNING APPLICATOR IN THE FIELD.
- TERMINAL LUBRICANT IS RECOMMENDED.
- 6. UNLESS SPECIFIED OTHERWISE TORQUE VALUES SHALL BE USED PER DOCUMENT, 101-35000.

**\*WARNING**  
ON INSTALLATION, SET WIRE DISC TO CRIMP HEIGHT REFERENCE SETTING FOR LARGEST WIRE SIZE. CRIMP HEIGHT REFERENCE SETTINGS GREATER THAN THE VALUE SHOWN MAY CAUSE DAMAGE TO THE CRIMP TOOLING. REFER TO THE INSTRUCTION SHEET FOR PROPER SETUP AND ADJUSTMENTS.

REVISIONS					
P	LTN	DESCRIPTION	DATE	OWN	APVD
D		ECR-18-015209	24SEP2018	JAH	TE
E		ECR-19-005557	05APR2019	JAH	CT
E1		ECR-19-019190	10DEC2019	FJ	TE
E2		ECR-21-005485	17MAY2021	AJ	YY

-	1	-	1	-	2119641-1	FEED CAM, AIR FEED	248	
-	1	1	1	1	2119082-4	CAM, SNAIL, INSULATION ADJUSTMENT	244	
-	1	1	1	1	2079764-1	WASHER, WAVE SPRING, CREST-TO-CREST	243	
	1	1	1	1	2119083-1	RETAINER, INSULATION DIAL	242	
-	1	1	1	1	18023-1	SCR, SKT HD CAP M3 X 5.0	241	
-	-	1	-	1	2119580-1	MECHANICAL FEED ASSEMBLY	239	
-	1	-	1	-	2844940-1	AIR FEED MODULE	238	
-	REF	REF	REF	REF	994970-2	COUNTER, MAGNETIC	164	
	1	1	1	1	1-18028-2	WASHER, FLAT, REG M4	119	
-	1	1	1	1	2119955-1	ASSY, LUBRICATOR, SIDE FEED	113	
-	1	1	1	1	2844908-1	SCREW, LOCKING	99	
-	1	1	1	1	2844907-1	POST, LOCKING	98	
-	1	1	1	1	455888-5	SPACER, CRIMPER	82	
-	1	1	1	1	1803607-3	DOCUMENTATION PACKAGE	71	
-	1	1	1	1	2119791-5	DEPRESSOR, WIRE	70	
-	1	1	1	1	2119943-1	WASHER, SPACER	69	
-	1	1	1	1	2119740-1	TAG, IDENTIFICATION	67	
-	2	2	2	2	2168078-1	SCREW, DRIVE, RH, RoHS, 2 x .188	66	
-	1	1	1	1	2168083-2	SCR, SKT HD CAP, RoHS, M4 X 8.0	60	
-	1	1	1	1	5-18022-5	SCR, HEX HD CAP, M4 X 6.0	59	
-	1	1	1	1	1338685-1	PAWL, FEED	56	
-	4	4	4	4	2168083-3	SCR, SKT HD CAP, RoHS, M4 X 12.0	54	
-	2	2	2	2	2168083-3	SCR, SKT HD CAP, RoHS, M4 X 12.0	53	
-	1	1	1	1	1803382-6	HOLD DOWN, SPRING LOADED	50	
-	1	2	1	2	18023-9	SCR, SKT HD CAP M4 X 6.0	49	
-	-	1	-	1	2119652-1	FEED CAM, PRE FEED	48	
-	-	1	-	1	2119653-1	FEED CAM, POST FEED	47	
-	1	1	1	1	1803583-9	APPLICATOR BASIC ASSEMBLY, SF	46	
-	1	1	1	1	1803515-1	RAM ASSEMBLY, SF ATLANTIC	44	
-	1	1	1	1	1803602-1	SCR, BHSC, RoHS (M8 X 25)	41	
-	1	1	1	1	1752356-4	SUPPORT, TERMINAL	34	
-	2	2	2	2	2079383-5	SCR, BHSC, RoHS (M4 X 20)	33	
-	2	2	2	2	2-2844962-4	SPACER, CYLINDRICAL, STRIP GUIDE	30	
-	1	1	1	1	2844992-2	ASSEMBLY, STRIP GUIDE	29	
-	1	1	1	1	1-455888-0	SPACER, CRIMPER	28	
-	1	1	1	1	1320928-2	STRIP GUIDE	24	
-	1	1	1	1	2168083-2	SCR, SKT HD CAP, RoHS, M4 X 8.0	21	
-	1	1	1	1	1-18028-2	WASHER, FLAT, REG M4	20	
-	1	1	1	1	2119533-1	STRIPPER, SIDE FEED	19	
	1	1	1	1	2119806-1	INSERT, SHEAR	13	
-	1	1	1	1	3-22280-3	SPRING, COMPRESSION	12	
-	1	1	1	1	1-356885-4	STOP, SHEAR	11	
	1	1	1	1	2119805-1	SHEAR HOLDER, FRONT	10	
	1	1	1	1	1803095-1	FLOATING SHEAR, FRONT	9	
	1	2	2	1	1	6-1633139-8	ANVIL, COMBINATION	8
-	1	1	1	1	240641-6	SPACER	7	
-	-	-	-	-	-	-	6	
-	1	1	1	1	2119757-8	DEPRESSOR, SHEAR	5	
-	1	1	1	1	238011-4	BLOCK, CRIMPER SPACER	4	
	1	2	2	1	1	1633965-8	CRIMPER, INSULATION O PREMIUM	3
-	-	-	-	-	-	-	2	
	1	2	2	1	1	456402-1	CRIMPER, WIRE PREMIUM	1
-77	-72	-71	-2	-1	PART NO	DESCRIPTION	ITEM NO	

ATLANTIC VERSION  
Shown on sheets 1 of 4 & 2 of 4  
(Pacific version shown on sheets 3 of 4 & 4 of 4)

THIS DRAWING IS A CONTROLLED DOCUMENT.		OWN R. O. WILSON CHK L. A. GROSS APVD T. L. ELBIN	12JAN2012 12JAN2012 13JAN2012		NAME Ocean Side Feed Applicator
DIMENSIONS: mm	TOLERANCES UNLESS OTHERWISE SPECIFIED:	PRODUCT SPEC	APPLICATION SPEC		SIZE CAGE CODE DRAWING NO A100779C=2151482
MATERIAL	FINISH	WEIGHT	SCALE	SHEET 1 OF 4	REV E2

Customer Accessible Production Drawing

REVISIONS				
P.	LTN	DESCRIPTION	DATE	APVD
-	-	SEE SHEET 1	-	-

# FEED TYPE MECHANICAL

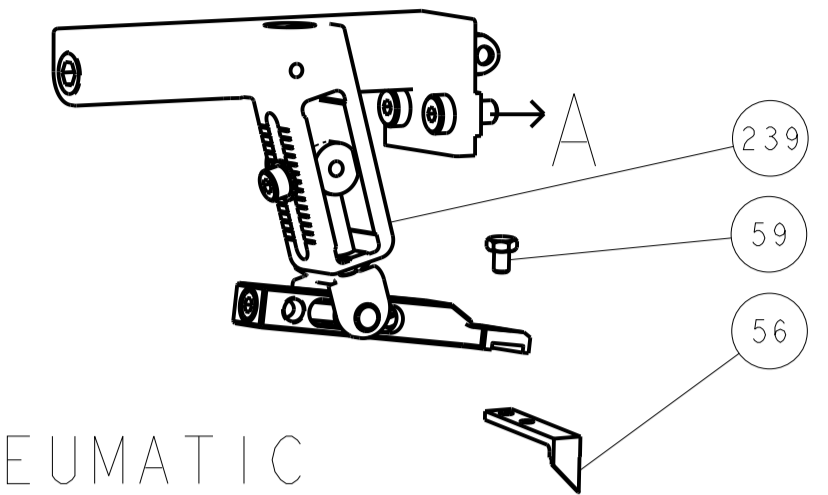

## PNEUMATIC

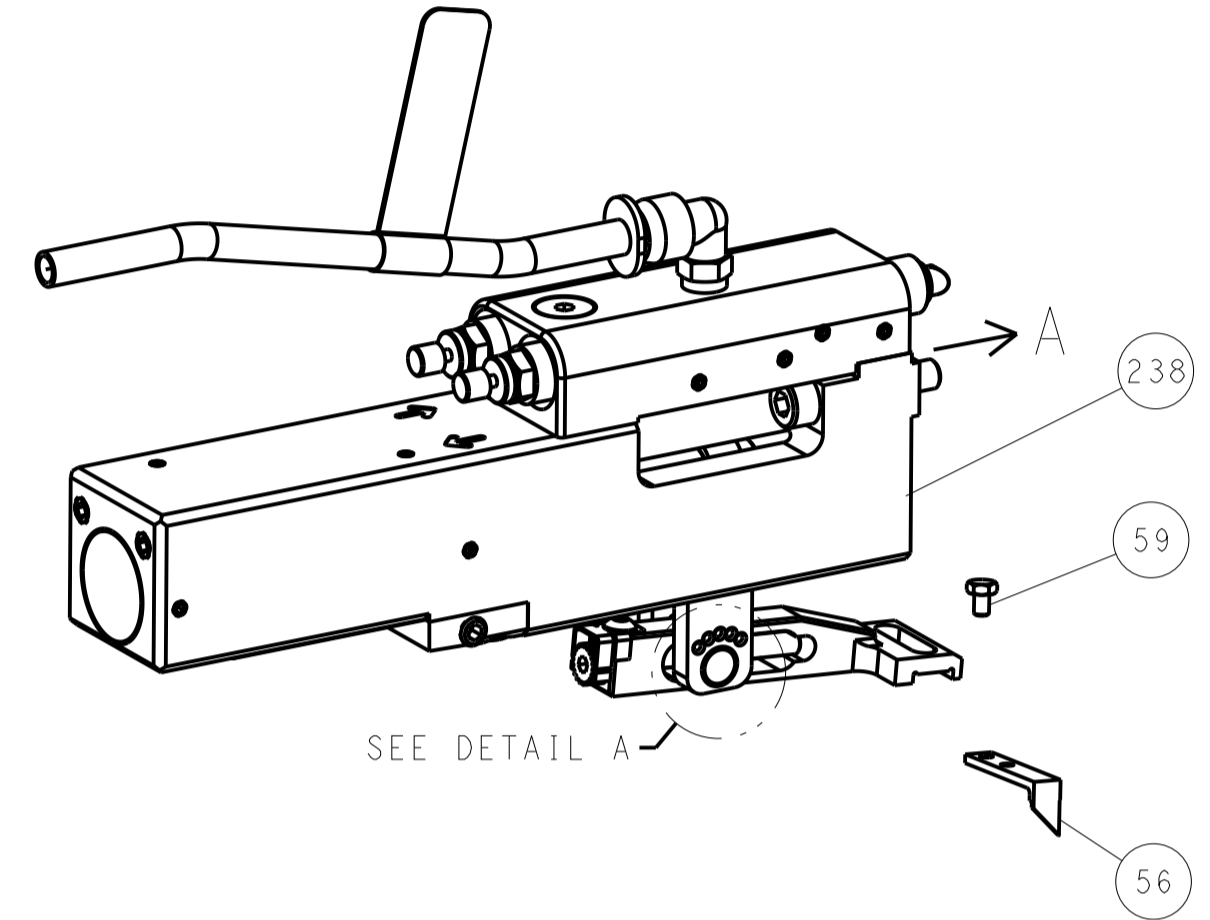

## FEED SPRING SETTING POSITION (SHOWN FROM REAR SIDE)

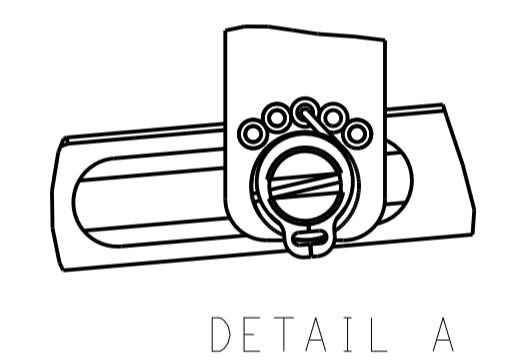

DETAIL A

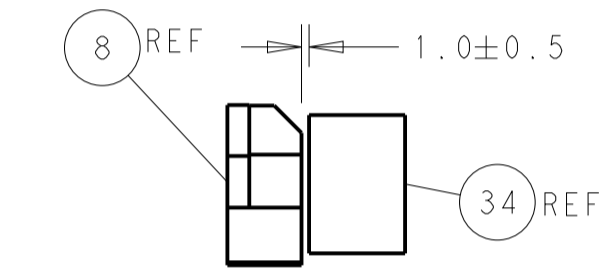
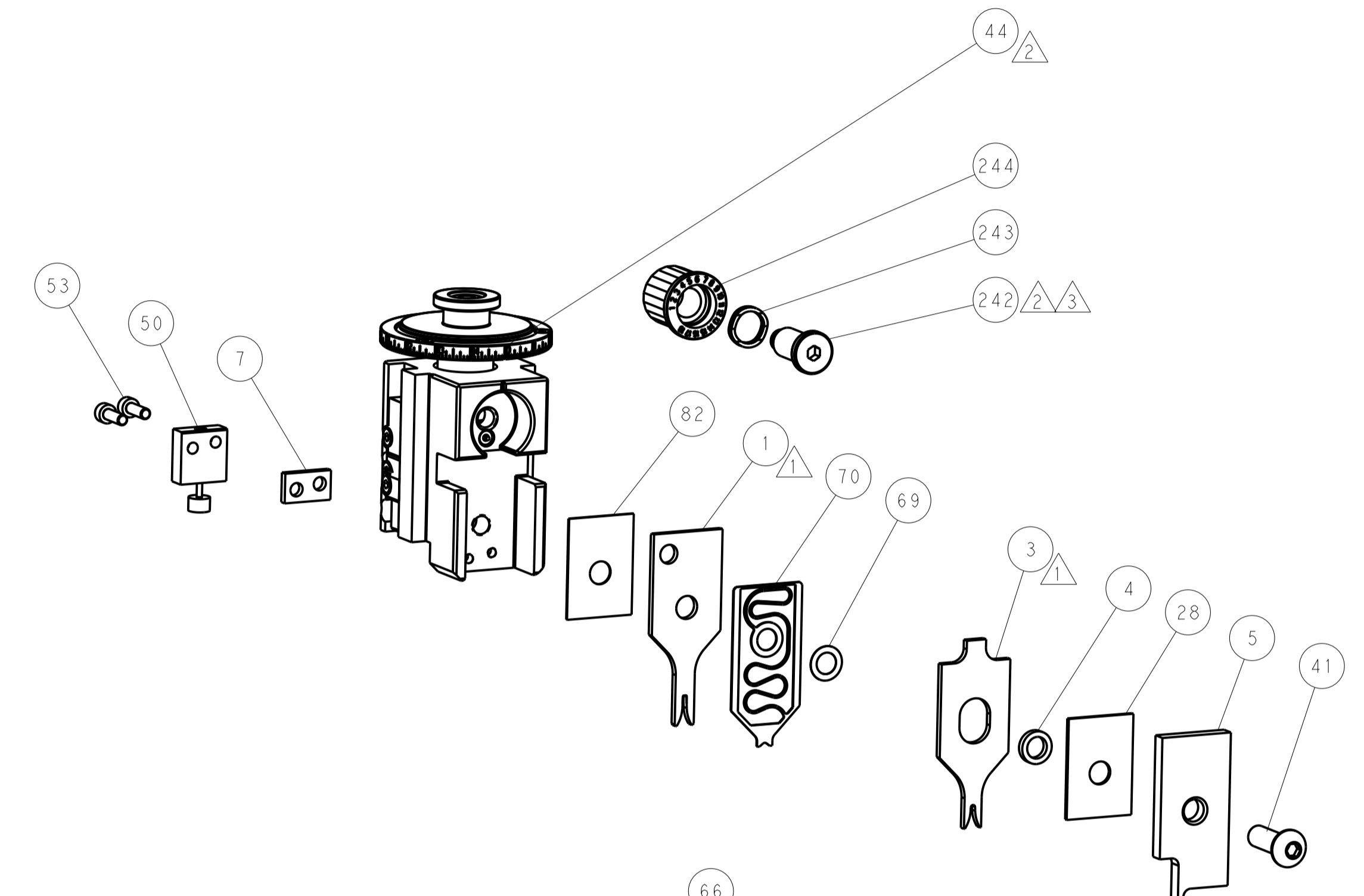

TERMINAL SUPPORT LOCATION

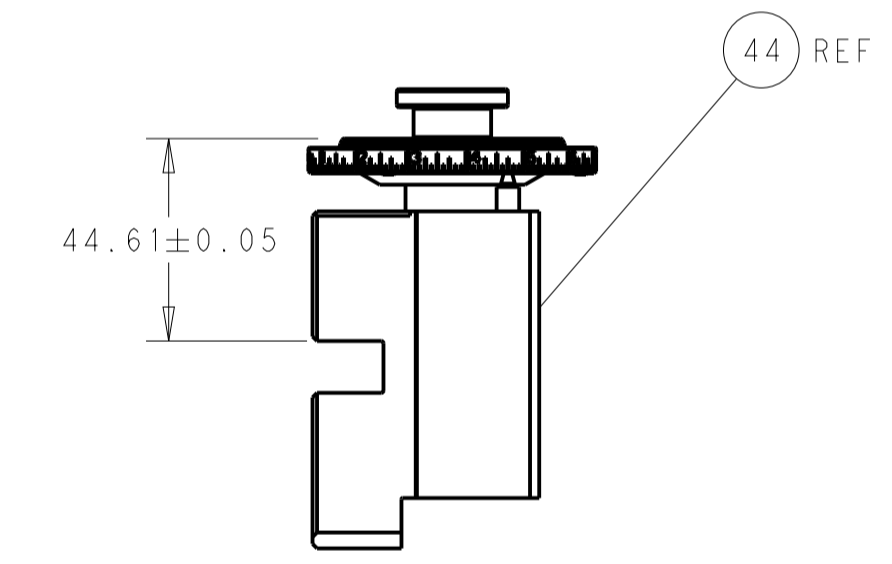

RAM SET-UP

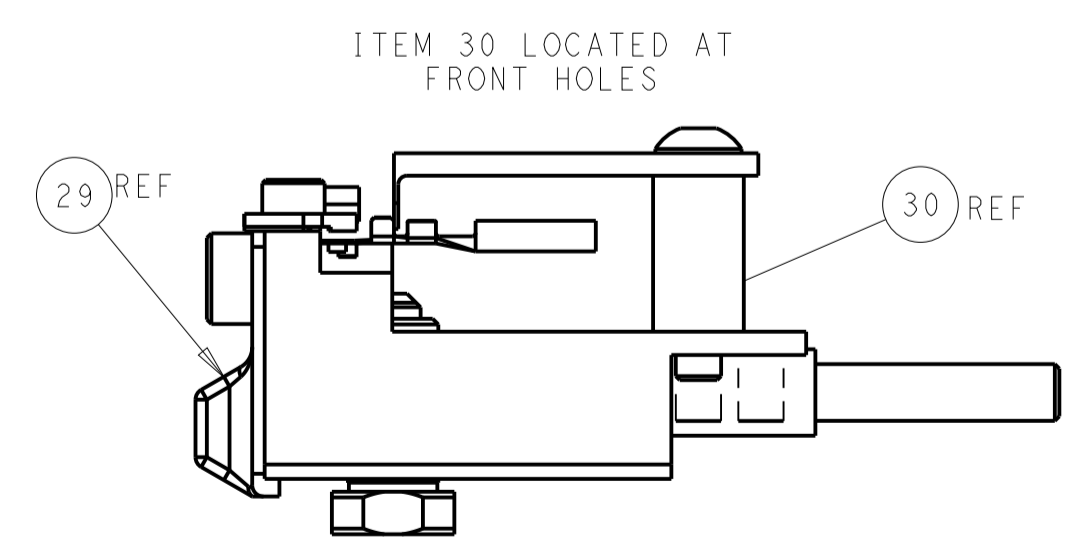

ITEM 30 LOCATED AT FRONT HOLES

# CAM POSITIONS

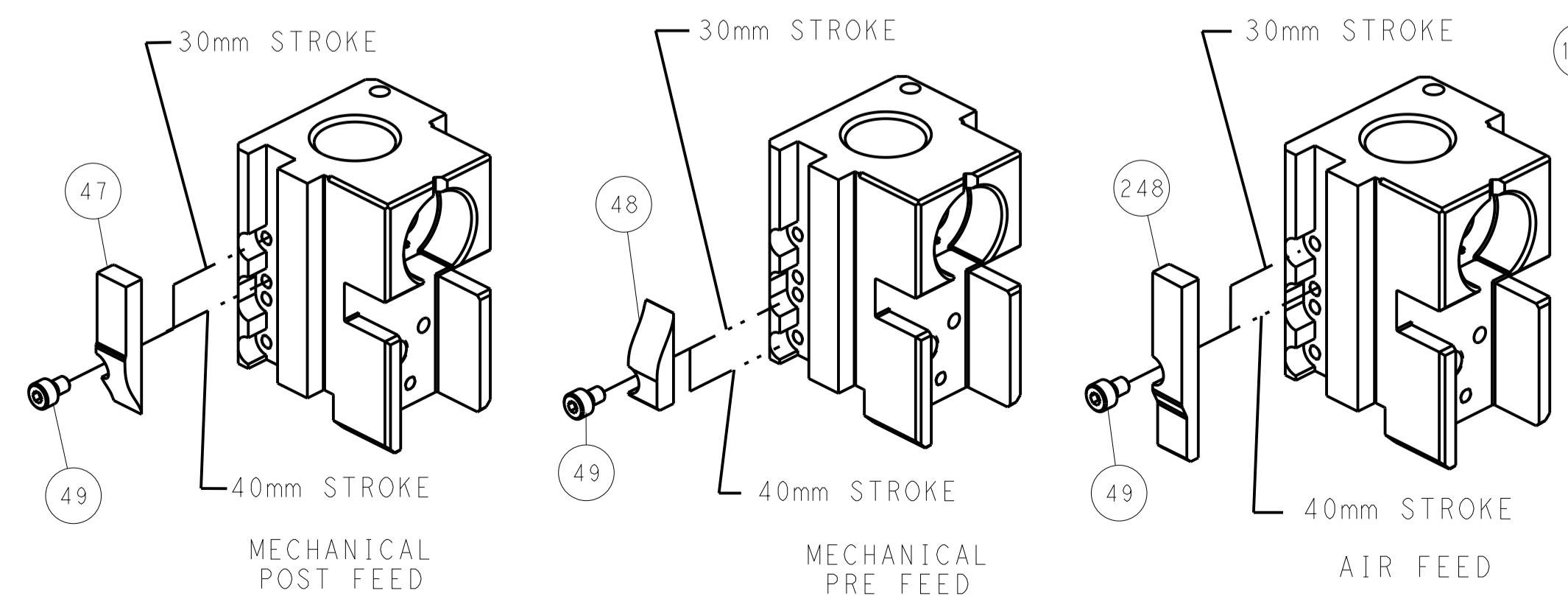

**ATLANTIC VERSION**  
 Shown on sheets 1 of 4 & 2 of 4  
 (Pacific version shown on sheets 3 of 4 & 4 of 4)

THIS DRAWING IS A CONTROLLED DOCUMENT.		OWN: R. Q. WILSON 12JAN2012	TE Connectivity
DIMENSIONS: mm		CHK: L. A. GROSS 12JAN2012	
TOLERANCES UNLESS OTHERWISE SPECIFIED:		APVD: T. L. ELBIM 13JAN2012	NAME: Ocean Side Feed Applicator
0 PLC ± 1 PLC ± 2 PLC ± 3 PLC ± 4 PLC ± ANGLES ±		PRODUCT SPEC	RESTRICTED TO
MATERIAL		APPLICATION SPEC	SIZE: CAGE CODE DRAWING NO
FINISH		WEIGHT	A100779C=2151482
		Customer Accessible Production Drawing	SCALE: 1:2 SHEET 2 OF 4 REV E2

PART NUMBER	REVISION	DESCRIPTION	FEED TYPE
2-2151482-1	D	FINE CRIMP HEIGHT ADJUST	MECHANICAL
2-2151482-2	E	FINE CRIMP HEIGHT ADJUST	PNEUMATIC
7-2151482-7	A	CRIMP TOOLING KIT	-

PACIFIC VERSION TERMINATOR  
INTERFACE ADAPTER



APPLICATOR DATA		
CRIMP	SIZE	TYPE
WIRE	1.40 mm [.055]	F
INSUL	1.78 mm [.070]	O

APPLICATOR INSTRUCTIONS  
408-35042

TERMINAL DATA: TE TERMINAL		TE CRIMP SPECIFICATION	
TERMINAL NAME: AMP MCP 1.5K FLAT TYPE RECEPTACLE			
WIRE STRIP LENGTH 3.10-3.70 mm [1.22-.146 IN]		INSULATION DIAMETER RANGE Ø1.20-1.40 mm [.047-.055 IN]	
TERMINAL APPLICATION SPECIFICATION	114-18386	-	-
TERMINALS APPLIED			
TE TERMINAL	TE TERMINAL	TE TERMINAL	TE TERMINAL
1564980-1	1564980-2	1418406-1	

WIRE SIZE	CRIMP HEIGHT mm [INCH]	CRIMP HEIGHT REFERENCE SETTING
0.35mm2	0.93+/-0.03 [.037+/-0.001]	9.1
0.22mm2	0.86+/-0.03 [.034+/-0.001]	10.0

**\*WARNING**  
ON INSTALLATION, SET WIRE DISC TO CRIMP HEIGHT REFERENCE SETTING FOR LARGEST WIRE SIZE. CRIMP HEIGHT REFERENCE SETTINGS GREATER THAN THE VALUE SHOWN MAY CAUSE DAMAGE TO THE CRIMP TOOLING. REFER TO THE INSTRUCTION SHEET FOR PROPER SETUP AND ADJUSTMENTS.

- 1 RECOMMENDED SPARE PARTS
- 2 REFER TO SUPPLIED INSTRUCTION SHEET FOR CLEANING, LUBRICATION AND STORAGE OF APPLICATOR.
- 3 APPLY PART NUMBER 2-23419-6 LOCTITE TO THREADS OF ITEM 242.
- 4 CRIMP HEIGHT REFERENCE SETTING WAS THE SETTING USED WHEN THE APPLICATOR WAS QUALIFIED AT THE FACTORY. ADJUSTMENT MAY BE NECESSARY WHEN RUNNING APPLICATOR IN THE FIELD.
- 5 TERMINAL LUBRICANT IS RECOMMENDED.
- 6 UNLESS SPECIFIED OTHERWISE TORQUE VALUES SHALL BE USED PER DOCUMENT, 101-35000.

ENTRY LEVEL APPLICATOR		ITEM SUBSTITUTION LIST		
PART NUMBER	SAME AS	ITEM	ITEM DESCRIPTION	SUBSTITUTE PART NUMBER
8-2151482-1	2151482-1	1	WIRE CRIMPER	1803530-1
8-2151482-2	2151482-2	3	INSULATION CRIMPER	1803624-8
9-2151482-1	2-2151482-1	46	BASIC SUB -ASSEMBLY	1803940-9
9-2151482-2	2-2151482-2	141	BASIC SUB -ASSEMBLY	1-1803940-0
			LUBRICATOR	DELETE

REVISIONS				
P	LTN	DESCRIPTION	DATE	APPD
-	-	SEE SHEET 1	-	-

-	1	1	2119082-4	CAM, SNAIL, INSULATION ADJUSTMENT	244
-	1	1	2079764-1	WASHER, WAVE SPRING, CREST-TO-CREST	243
-	1	1	2119083-1	RETAINER, INSULATION DIAL	242
-	1	1	18023-1	SCR, SKT HD CAP M3 X 5.0	241
-	-	1	2119580-1	MECHANICAL FEED ASSEMBLY	239
-	1	-	2844940-1	AIR FEED MODULE	238
-	REF	REF	994970-2	COUNTER, MAGNETIC	164
-	1	-	2119641-2	FEED CAM, AIR FEED	151
-	1	1	2168083-8	SCR, SKT HD CAP, RoHS, M4 X 16	144
-	4	4	2168083-9	SCR, SKT HD CAP, RoHS, M4 X 20	143
-	-	1	2119653-2	FEED CAM, POST FEED	142
-	1	1	1-1803583-0	APPLICATOR BASIC ASSEMBLY, SF	141
-	1	1	1803516-1	RAM ASSEMBLY, SF PACIFIC	140
-	1	1	1-18028-2	WASHER, FLAT, REG M4	119
-	1	1	2119955-1	ASSY, LUBRICATOR, SIDE FEED	113
-	1	1	2844908-1	SCREW, LOCKING	99
-	1	1	2844907-1	POST, LOCKING	98
-	1	1	455888-5	SPACER, CRIMPER	82
-	1	1	1803607-3	DOCUMENTATION PACKAGE	71
-	1	1	2119791-5	DEPRESSOR, WIRE	70
-	1	1	2119943-1	WASHER, SPACER	69
-	1	1	2119740-1	TAG, IDENTIFICATION	67
-	2	2	2168078-1	SCREW, DRIVE, RH, RoHS, 2 x .188	66
-	1	1	5-18022-5	SCR, HEX HD CAP, M4 X 6.0	59
-	1	1	1338685-1	PAWL, FEED	56
-	2	2	2168083-3	SCR, SKT HD CAP, RoHS, M4 X 12.0	53
-	1	1	1803382-6	HOLD DOWN, SPRING LOADED	50
-	1	2	18023-9	SCR, SKT HD CAP M4 X 6.0	49
-	-	1	2119652-1	FEED CAM, PRE FEED	48
-	1	1	1803602-1	SCR, BHSC, RoHS (M8 X 25)	41
-	1	1	1752356-4	SUPPORT, TERMINAL	34
-	2	2	2079383-5	SCR, BHSC, RoHS (M4 X 20)	33
-	2	2	2-2844962-4	SPACER, CYLINDRICAL, STRIP GUIDE	30
-	1	1	2844992-2	ASSEMBLY, STRIP GUIDE	29
-	1	1	1-455888-0	SPACER, CRIMPER	28
-	1	1	1320928-2	STRIP GUIDE	24
-	1	1	2168083-2	SCR, SKT HD CAP, RoHS, M4 X 8.0	21
-	1	1	1-18028-2	WASHER, FLAT, REG M4	20
-	1	1	2119533-1	STRIPPER, SIDE FEED	19
-	1	1	2119806-1	INSERT, SHEAR	13
-	1	1	3-22280-3	SPRING, COMPRESSION	12
-	1	1	1-356885-4	STOP, SHEAR	11
-	1	1	2119805-1	SHEAR HOLDER, FRONT	10
-	1	1	1803095-1	FLOATING SHEAR, FRONT	9
-	1	1	1-1633139-8	ANVIL, COMBINATION	8
-	1	1	240641-6	SPACER	7
-	-	-	-	-	6
-	1	1	2119757-8	DEPRESSOR, SHEAR	5
-	1	1	238011-4	BLOCK, CRIMPER SPACER	4
-	1	1	1633965-8	CRIMPER, INSULATION O PREMIUM	3
-	-	-	-	-	2
-	1	1	456402-1	CRIMPER, WIRE PREMIUM	1

PACIFIC VERSION  
Shown on sheets 3 of 4 & 4 of 4  
(Atlantic version shown on sheets 1 of 4 & 2 of 4)

THIS DRAWING IS A CONTROLLED DOCUMENT. OWN: R. O. WILSON 12JAN2012, CHK: L. A. GROSS 12JAN2012, APVD: T. L. ELBIN 13JAN2012

**STE** TE Connectivity

NAME: Ocean Side Feed Applicator

SIZE: CAGE CODE DRAWING NO: A100779C=2151482

Customer Accessible Production Drawing SCALE: 1:2 SHEET 3 OF 4 REV: E2

REVISIONS				
P.	LTN.	DESCRIPTION	DATE	APVD.
-	-	SEE SHEET 1	-	-

# FEED TYPE MECHANICAL

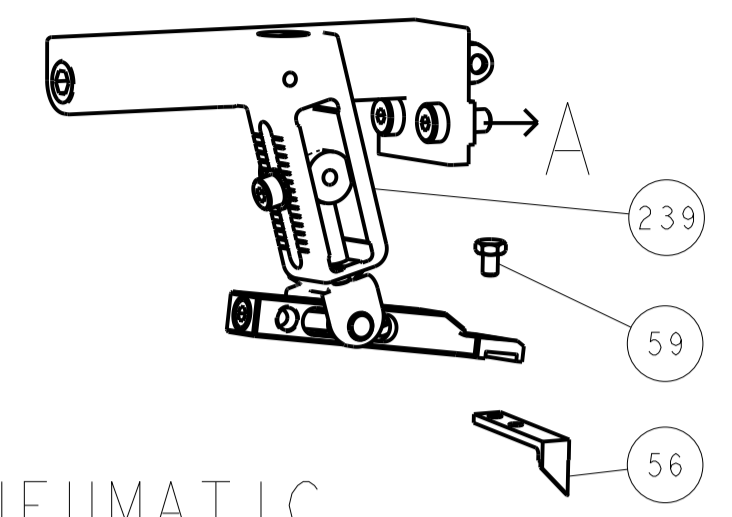

# PNEUMATIC

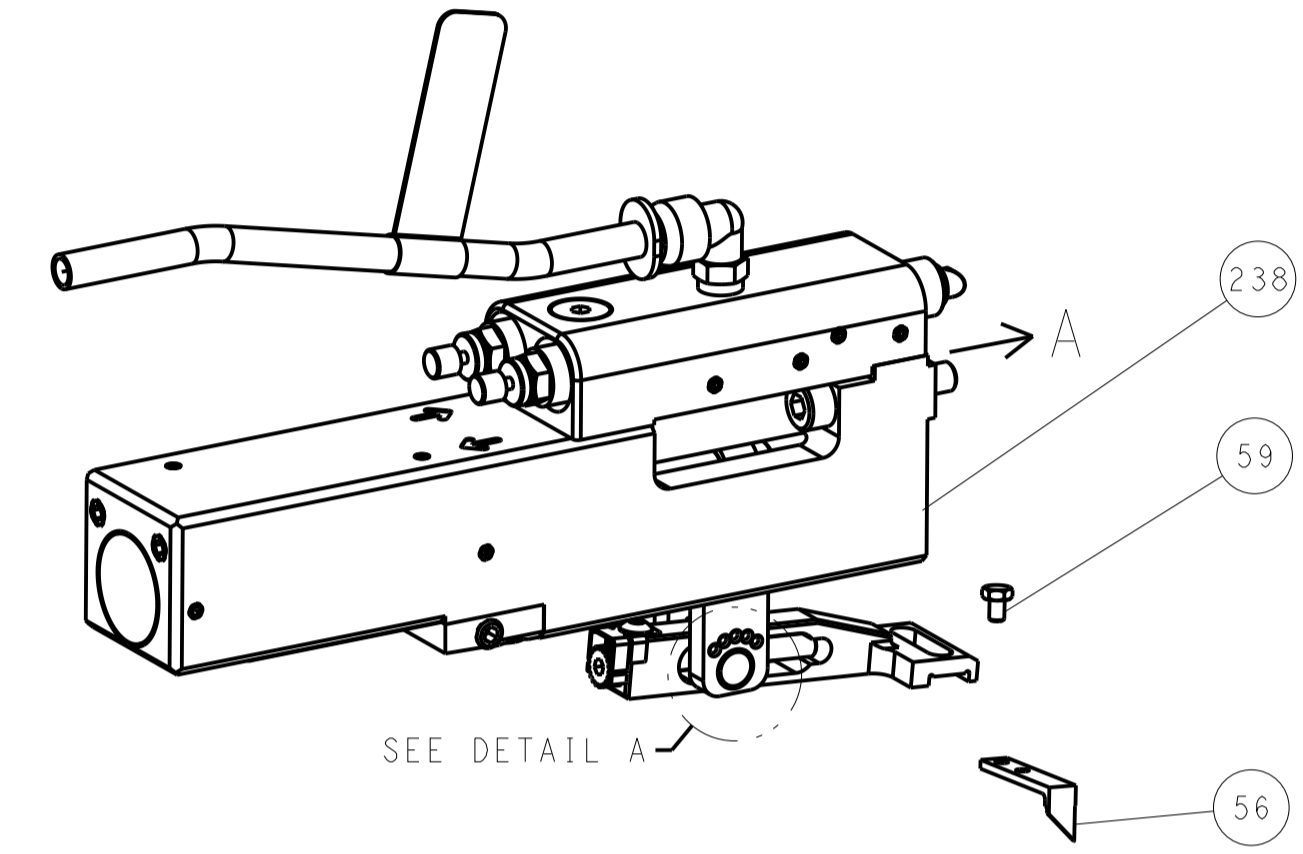

# FEED SPRING SETTING POSITION (SHOWN FROM REAR SIDE)

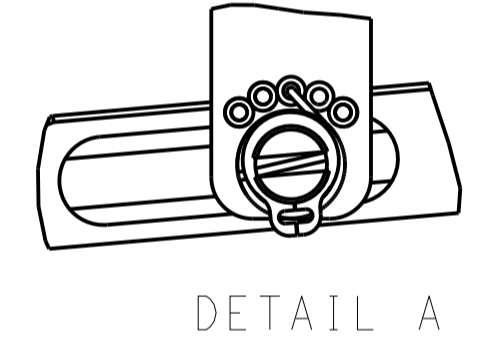

# CAM POSITIONS

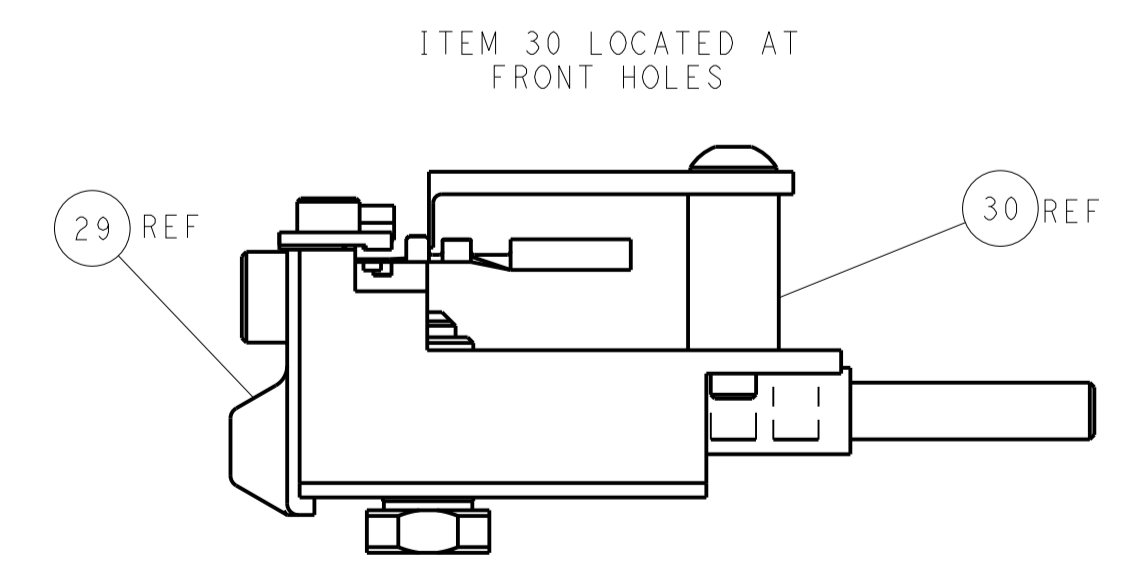
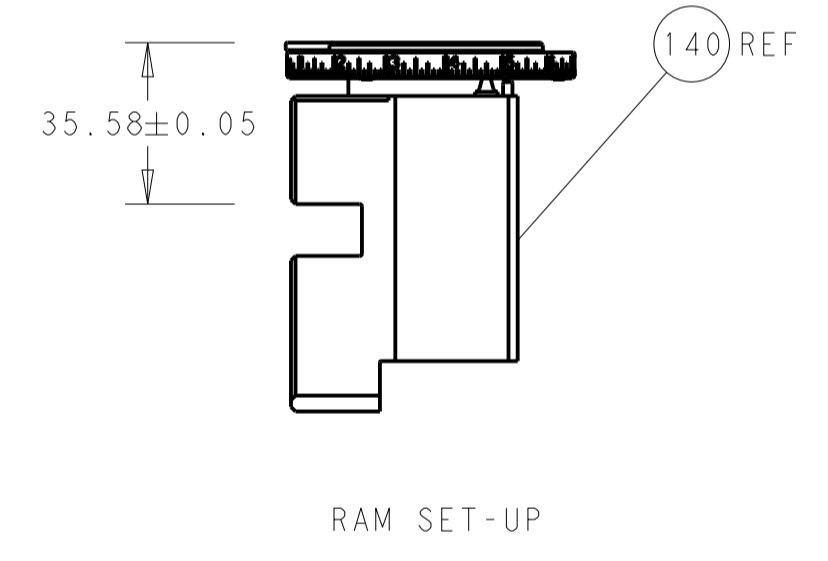
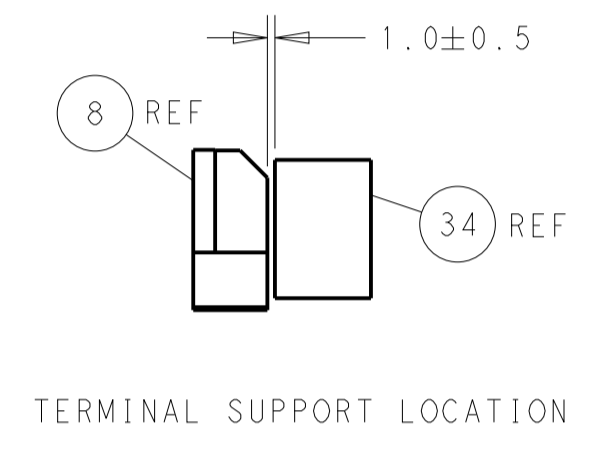
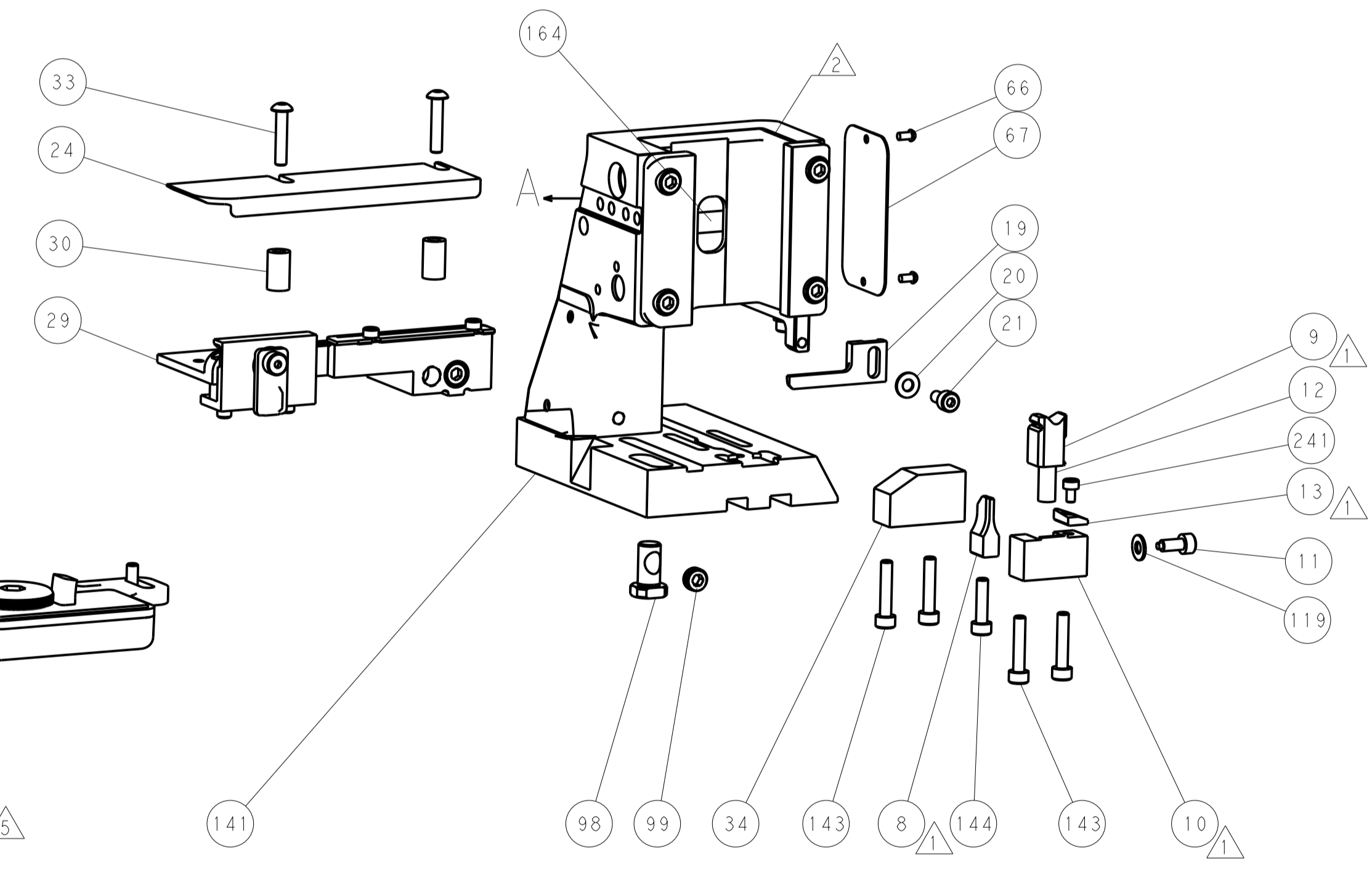
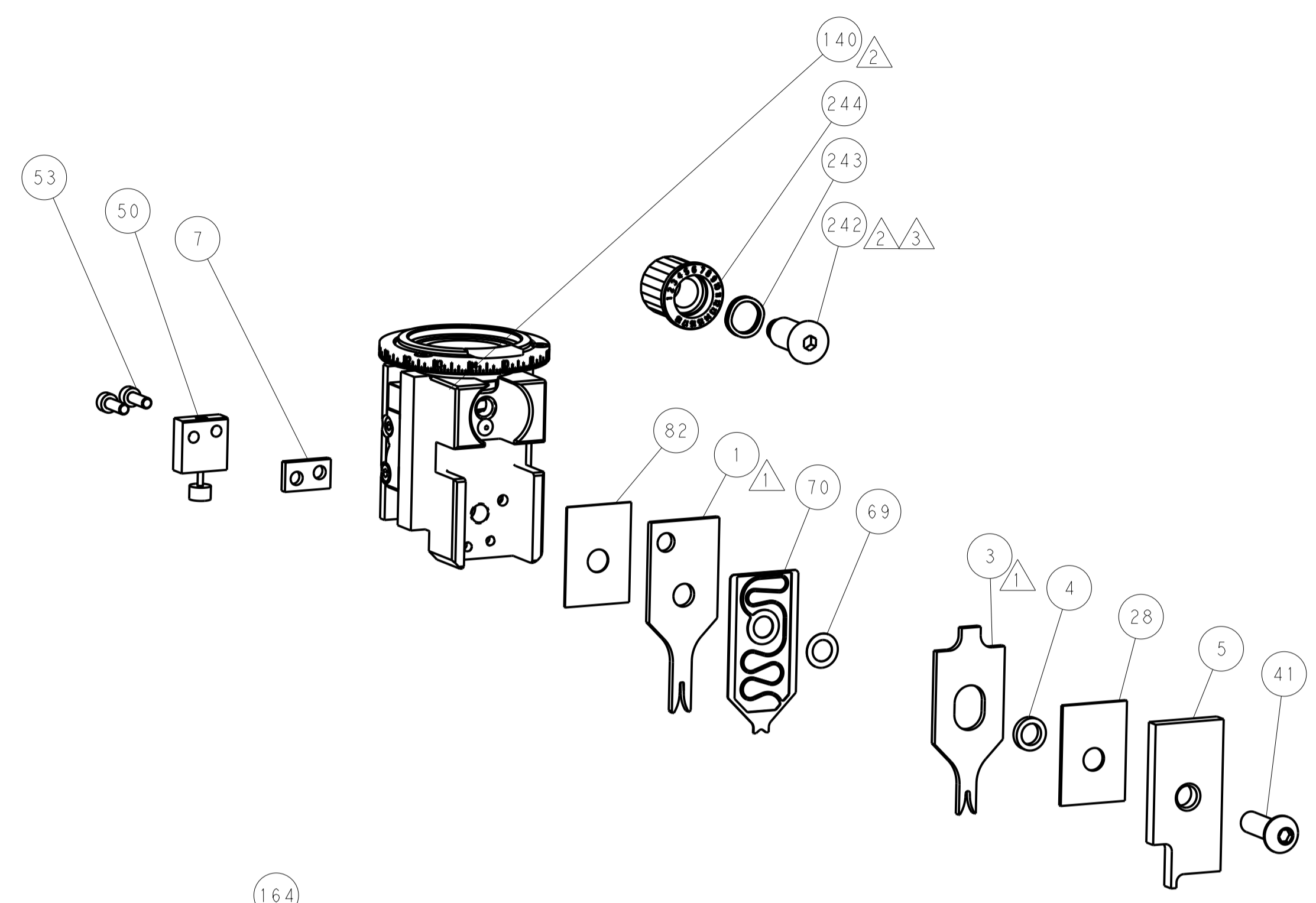
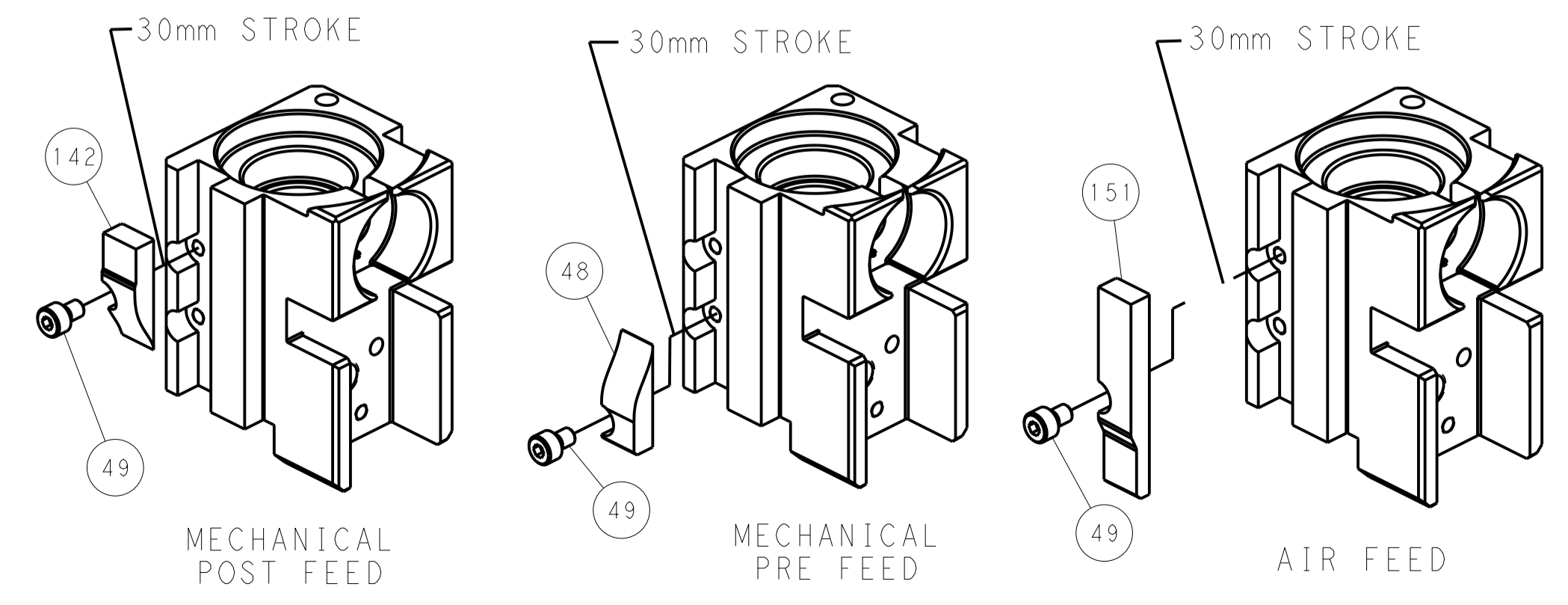

**PACIFIC VERSION**  
 Shown on sheets 3 of 4 & 4 of 4  
 (Atlantic version shown on sheets 1 of 4 & 2 of 4)

THIS DRAWING IS A CONTROLLED DOCUMENT.		OWN: R. O. WILSON 12JAN2012	<b>STE</b> TE Connectivity
DIMENSIONS: mm		CHK: L. A. GROSS 12JAN2012	
TOLERANCES UNLESS OTHERWISE SPECIFIED:		APVD: T. L. ELBIM 13JAN2012	NAME: Ocean Side Feed Applicator
0 PLC ±		PRODUCT SPEC	SIZE: CAGE CODE DRAWING NO
1 PLC ±		APPLICATION SPEC	RESTRICTED TO
2 PLC ±		WEIGHT	A100779C=2151482
3 PLC ±		Customer Accessible Production Drawing	SCALE: 1:2 SHEET 4 OF 4 REV: E2
4 PLC ±			
ANGLES			