

P	LTR	DESCRIPTION	DATE	DWN	APVD
	C3	REVISED PER ECO-21-007118	30JUN2021	RK	DR

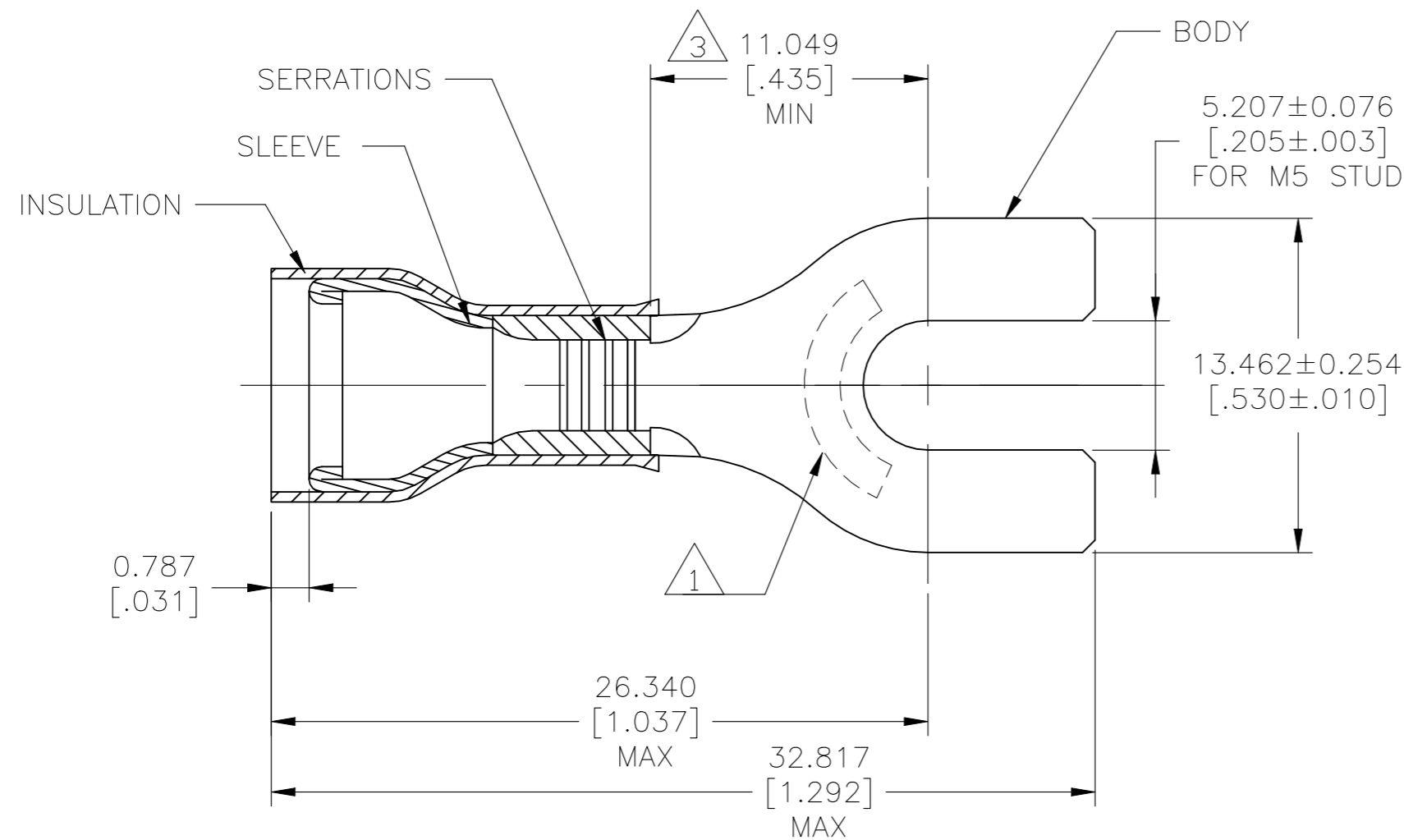

- 1 STAMP "AMP 12-10\*", APPROX AS SHOWN.
- 2 BODY MATERIAL THICKNESS IS  $0.991 \pm 0.051$  [.039±.002]
- 3 APPLIES FROM EDGE OF METAL WIRE BARREL TO CENTER OF STUD HOLE.
- 4 WIRE INSULATION DIA 3.810-6.350 [.150-.250]
- 5 BODY - COPPER PER ASTM B152  
SLEEVE - COPPER PER ASTM B152  
INSULATION - NYLON
- 6 BODY - TIN PL 0.00254[.000100] MIN EXT THK PER ASTM B545  
SLEEVE - TIN PL 0.00254[.000100] MIN EXT THK PER ASTM B545  
INSULATION - COLOR - YELLOW
- 7 105°C [221 F] MAX OPERATING TEMPERATURE.
- 8 300 VOLT MAX
- 9 2.62-6.64mm<sup>2</sup> [5,180 - 13,100 CMA] SOLID OR STRANDED

500	LOOSE PIECE	130620
QTY	PACKAGE TYPE	PART NO

THIS DRAWING IS A CONTROLLED DOCUMENT.		DWN jr_ruth 13APR07	TE Connectivity			
DIMENSIONS: mm [INCHES]		CHK T MICHELUTTI 13APR07				
TOLERANCES UNLESS OTHERWISE SPECIFIED:		APVD T MICHELUTTI 13APR07	NAME			
0 PLC ± - 1 PLC ± - 2 PLC ± - 3 PLC ± 0.127[.005] 4 PLC ± - ANGLES ± 5°		PRODUCT SPEC UL 486A-B	TERMINAL, SPADE TONGUE, PIDG, WIRE SIZE: 12-10 AWG			
MATERIAL		APPLICATION SPEC 114-2157	SIZE A3	CAGE CODE 00779	DRAWING NO C-130620	RESTRICTED TO -
FINISH		WEIGHT	SCALE 4:1		SHEET 1 OF 1	REV C3
5		CUSTOMER DRAWING		6		