

# *ZWQ Series*

## *ZWQ80/130*

# *Instruction Manual*

### **BEFORE USING THE POWER SUPPLY UNIT**

Pay attention to all warnings and cautions before using the unit. Incorrect usage could lead to an electrical shock, damage to the unit or a fire hazard.

### **WARNING and CAUTION**

- Do not modify.
- Do not touch the internal components, they may have high voltage or high temperature. You may get electrical shock or burned.
- When the unit is operating, keep your hands and face away from it, you may get injured by an accident.
- This power supply is primarily designed and manufactured to be used and enclosed in other equipment. Stick the WARNING label for users on the system equipment and describe the notice in the instruction manual.
- Never operate the unit under over current or shorted conditions for 30 seconds or more and except Input Voltage Range in specification which could result in damage or insulation failure or smoking or burning.
- Confirm connections to input/output terminals are correct as indicated in the instruction manual.
- This powersupply is PC board type unit. Please hold the board edge while mouting, and do not touch the component side. In using the apparatus, please lift the power supply with a metal spacer.
- Do not drop or apply shock to power supply unit.

## 1. Terminal Explanation

### ZWQ80

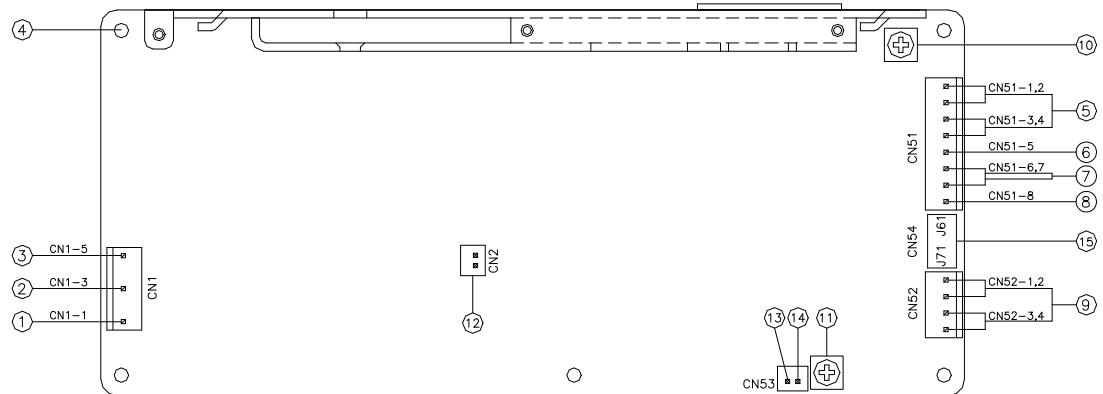

- ① L; AC Input terminal Live line ( Fuse in line )  
CN1 - 1
- ② N; AC Input terminal Neutral line  
CN1 - 3
- ③ FG; Input terminal FG (Safety earth :  $\perp$  )  
CN1 - 5  
Connect to safety ground of apparatus or equipment.
- ④ FG; Frame Ground  
Must be connected to electrically safety ground of apparatus or equipment by electrically conductive spacers. The mounting surface of the spacer should be within MAX 8mm.
- ⑤ V1 ( 5A max. / pin )  
CN51 - 1,2 : V1 + Output pin  
CN51 - 3,4 : V1 Ground
- ⑥ V2 ( 5A max. / pin )  
CN51 - 5 : V2 + Output pin
- ⑦ V2,V3 ( 5A max. / pin )  
CN51 - 6,7 : V2,V3 Common Ground
- ⑧ V3 ( 5A max. / pin )  
CN51 - 8 : V3 - Output pin
- ⑨ V4 ( 5A max. / pin )  
CN52 - 1,2 : V4 + Output pin  
CN52 - 3,4 : V4 Ground
- ⑩ VR51; Output voltage of V1 adjustment trimmer
- ⑪ VR81; Output voltage of V4 adjustment trimmer  
The output voltage rises when a trimmer is turned clockwise.
- ⑫ CN2; Remote ON/OFF control at primary
- ⑬ CN53; Remote ON/OFF control at secondary : - R
- ⑭ CN53; Remote ON/OFF control at secondary : + R  
  
Can not use Remote ON/OFF control at with Cover type(/A).
- ⑮ Select jumper  
J61 Short : V2 Output voltage is +12V.  
J61 Open : V2 Output voltage is +15V.  
J71 Short : V3 Output voltage is -12V.  
J71 Open : V3 Output voltage is -15V.

**ZWQ130**

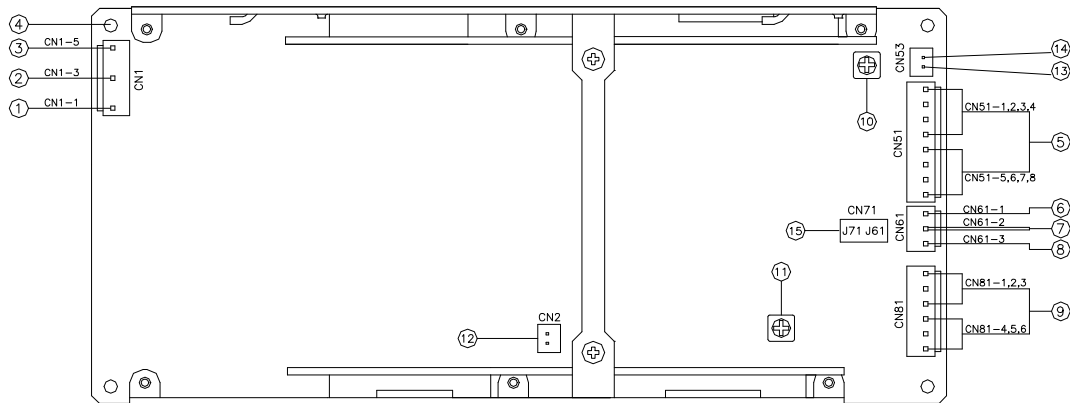

- |   |  |
|---|--|
| <p>① L; AC Input terminal Live line ( Fuse in line )<br/>         CN1 - 1</p> <p>② N; AC Input terminal Neutral line<br/>         CN1 - 3</p> <p>③ FG; Input terminal FG (Safety earth : <math>\perp</math> )<br/>         CN1 - 5<br/>         Connect to safety ground of apparatus or equipment.</p> <p>④ FG; Frame Ground<br/>         Must be connected to electrically safety ground of apparatus or equipment by electrically conductive spacer. The mounting surface of the spacer should be within MAX 8mm.</p> <p>⑤ V1 ( 5A max. / pin )<br/>         CN51 - 1,2,3,4 : V1 + Output pin<br/>         CN51 - 5,6,7,8 : V1 Ground</p> <p>⑥ V2 ( 5A max. / pin )<br/>         CN61 - 1 : V2 + Output pin</p> <p>⑦ V2,V3 ( 5A max. / pin )<br/>         CN61 - 2 : V2,V3 Common Ground</p> <p>⑧ V3 ( 5A max. / pin )<br/>         CN61 - 3 : V3 - Output pin</p> <p>⑨ V4 ( 5A max. / pin )<br/>         CN52 - 1,2,3 : V4 + Output pin<br/>         CN52 - 4,5,6 : V4 Ground</p> | <p>⑩ VR51; Output voltage of V1 adjustment trimmer</p> <p>⑪ VR81; Output voltage of V4 adjustment trimmer<br/>         The output voltage rises when a trimmer is turned clockwise.</p> <p>⑫ CN2; Remote ON/OFF control at primary</p> <p>⑬ CN53; Remote ON/OFF control at secondary : - R</p> <p>⑭ CN53; Remote ON/OFF control at secondary : + R</p> <p>Can not use Remote ON/OFF control at with Cover type(/A).</p> <p>⑮ Select jumper<br/>         J61 Short : V2 Output voltage is +12V.<br/>         J61 Open : V2 Output voltage is +15V.<br/>         J71 Short : V3 Output voltage is -12V.<br/>         J71 Open : V3 Output voltage is -15V.</p> |
|---|--|

## 2. Terminal connecting method

- Input must be off when making connections.
- Connect FG terminal of input connector and mountable FG to ground terminal of the equipment.
- Output current of each connector pin must be less than 5A.
- The output load line and input line shall be separated and twisted to improve noise sensitivity.
- Remote ON/OFF control lines shall be twisted or use shielded wire.
- When connecting or removing connector, do not apply stress to PCB.
- Use the input/output connector specified in outline drawing. Also, use recommended crimping tool. Connector is not included with this product.

### ZWQ80

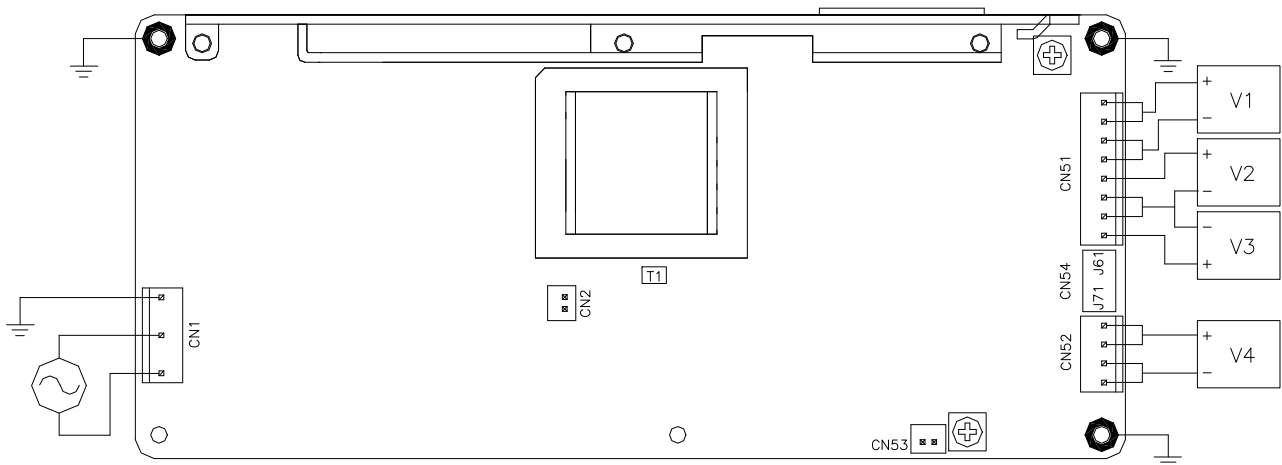

#### \* Input & Output connector ( J.S.T. )

	ZWQ80		
	Connector	Housing	Terminal Pin
Input(CN1)	B3P-5-VH	VHR-5N	SVH-21T-P1.1
Output(CN51)	B8P-VH	VHR-8N	SVH-21T-P1.1
Output(CN52)	B4P-VH	VHR-4N	SVH-21T-P1.1

\*Output Current of each connector pin must be less than 5A.

\* Hand Crimping Tool : YC-160R MANUFACT. : J.S.T.

#### \* Connector ( J.S.T. ) for Remote ON/OFF control

Connector	Housing	Terminal Pin
B2B - XH - AM	XHP - 2	BXH - 001T - P0.6 or SXH - 001T - P0.6

\*Can not use Remote ON/OFF control at With Cover type ( /A ).

\*Hand Crimping Tool : YC-110R or YSR-110 MANUFACT. : J.S.T.

\* CN2 is normally shorted by JM-2W-96 MANUFACT J.S.T.

**ZWQ130**

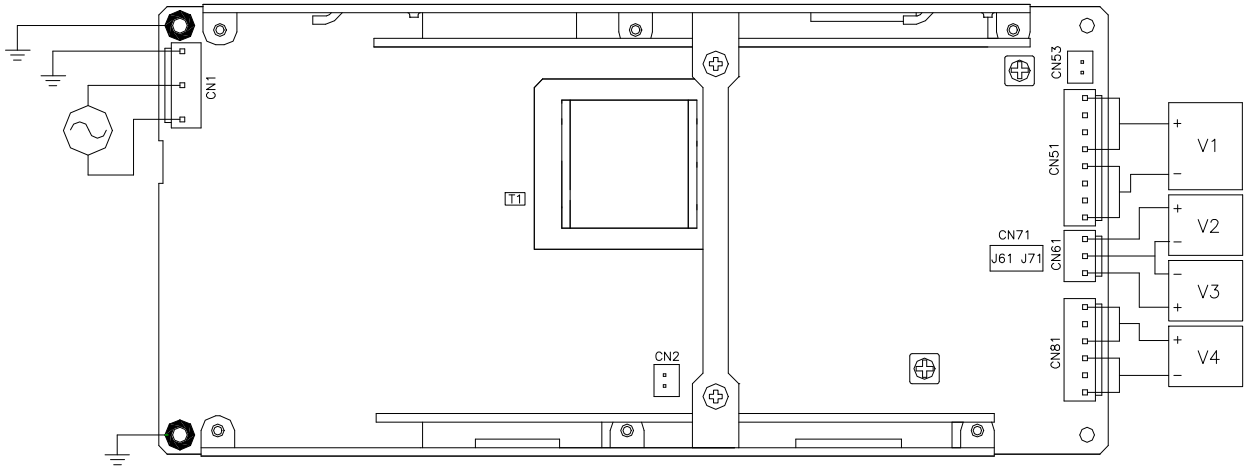

\* Input & Output connector ( J.S.T. )

	ZWQ130		
	Connector	Housing	Terminal Pin
Input(CN1)	B3P-5-VH	VHR-5N	SVH-21T-P1.1
Output(CN51)	B8P-VH	VHR-8N	SVH-21T-P1.1
Output(CN61)	B3P-VH	VHR-3N	SVH-21T-P1.1
Output(CN81)	B6P-VH	VHR-6N	SVH-21T-P1.1

\*Output Current of each connector pin must be less than 5A.

\* Hand Crimping Tool : YC-160R MANUFACT. : J.S.T.

\* Connector ( J.S.T. ) for Remote ON/OFF control

Connector	Housing	Terminal Pin
B2B - XH - AM	XHP - 2	BXH - 001T - P0.6 or SXH - 001T - P0.6

\*Can not use Remote ON/OFF control at With Cover type ( /A ).

\* Hand Crimping Tool : YC-110R or YSR-110 MANUFACT. : J.S.T.

\* CN2 is normally shorted by JM-2W-96 MANUFACT J.S.T.

### 3. Explanation of Functions and Precautions

#### 3-1. Input Voltage Range

Input voltage range is single phase 85 ~ 265VAC ( 47 ~ 63Hz ) or 120 ~ 370VDC. Input voltage which is out of specification may cause unit damage. For cases where conformance to various safety spec(UL,CSA,EN) are required, input voltage range of application for safety 100 ~ 240VAC ( 50/60Hz ).

#### 3-2. Output Voltage Range

V.ADJ trimmer ( VR51, VR81 ) can adjust the output voltage of V1 and V4 within the range. To turn the trimmer clockwise, the output voltage will be increased. Output voltage range of V1 is within 5 ~ 5.25V, V4 is following range. Note over voltage protection ( OVP ) function may trigger if the output voltage is increased excessively.

V4 Output Voltage Range	
5223;	2.0V ~ 3.63V
5225;	2.0V ~ 5.25V
5222;	11.4V ~ 12.6V
5224;	22.8V ~ 25.2V

#### 3-3. Inrush Current

This series has used Power Thermistor to protect the circuit from Inrush Current. Please carefully select input switch and fuse in cases of the high temperature and re-input the power.

#### 3-4. Wattbox

This series designed as a WATTBOX. You are flexibly adjust output power of each channel within the limit of the total allowable output power in specification.

$$W_{TOTAL} \geq W_{V1} + W_{V2} + W_{V3} + W_{V4}$$

- W<sub>V1</sub> : Less than maximum V1 output power.
- W<sub>V2</sub> : Less than maximum V2 output power.
- W<sub>V3</sub> : Less than maximum V3 output power.
- W<sub>V4</sub> : Less than maximum V4 output power.

#### 3-5. Minimum output Current

The output voltage of all channel is stabilized when minimum output current of V1 is more than 12% of maximum output current. Note all channel may not when V1 has no load.

#### 3-6. Over Voltage Protection ( OVP )

The OVP function ( Inverter shut down method, manual reset type ) built into each channel. (OVP function at V2 and V3 is total voltage detection method.) When OVP of each channel triggers, the all outputs will be shut down. The input shall be removed for a few minutes, and then re-input for recovery of the output to recover. OVP setting shall be fixed and not to be adjusted externally.

#### 3-7. Over Current Protection ( OCP )

Total & constant current limiting, automatic recovery. OCP function operates when the total maximum output power exceeds 102% of total allowable peak output power on specification. The output will be automatically recovered when the overload condition is canceled. Also, this unit employs total current detection for OCP. Therefore, take note that the unit might be damaged because OCP may not operate even if each channel exceeds each maximum output current specification. Never operate the unit under over current or shorted conditions over 30 seconds which could result in damage, insulation failure, smoking or burning.

#### 3-8. Output Ripple & Noise

The standard specification for maximum ripple value is measured according to measurement circuit specified by EIAJ-RC9131. When load lines are longer, ripple will becomes larger. In this case, electrolytic capacitor, film capacitor, etc. might be necessary to use across the load terminal. The output ripple cannot be measure accurately if the probe ground lead of oscilloscope is too long.

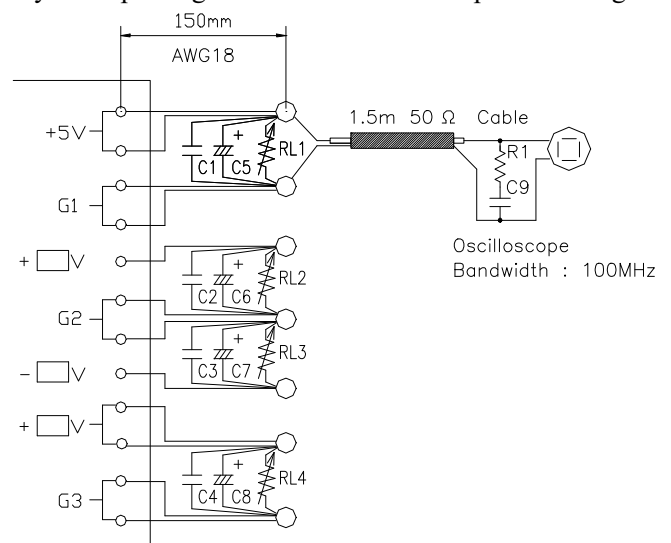

- (※) The number of terminal are different by model.
- (※) Oscilloscope Probe : please use a bayonet adapter or equivalent.

	Capacitance
C1,C2,C3,C4 : Film Cap.	0.1 μF
C5 : Elec. Cap.	1000 μF
C6,C7,C8 : Elec. Cap.	100 μF
C9 : Film Cap.	4700 pF
R1 : Resistor	50Ω

### 3-9. Peak Output Current

For ZWQ series, relation between maximum output current (Convection cooling) and peak output current must satisfy formulas below. Also operating time at peak output current(  $\tau$  ) should be less than 10sec, period(T) should be more than 10msec.  
 (Duty $\leq$ 0.35)

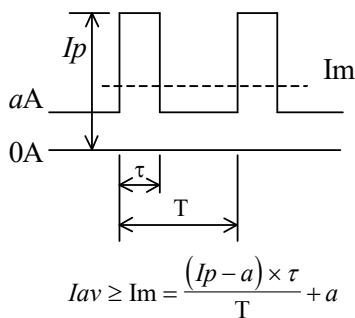
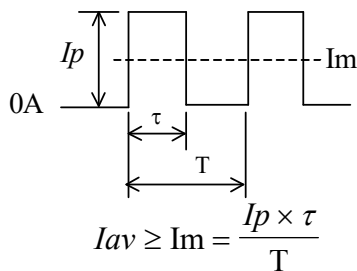

- $I_p$  : Peak output current ( A )
- $I_{av}$  : Maximum output current of Specification (Convection cooling) ( A )
- $I_m$  : Average output current ( A )
- $\tau$  : Pulse width of peak output current ( sec )  
( Operating time at peak output )
- T : Period (sec)

### 3-10. Remote ON/OFF Control

Remote ON/OFF control(CN2,CN52) function is available. Using this function allows the user to turn the all outputs on and off without having to turn the AC input on and off. Remote ON/OFF control can be used by following 2 modes

When shipping, CN2 is installed with a short connector. When use this function, must be put off a short connector.

However, for Cover & Chassis type (ZWQ/A), can not be used.

#### Primary side

A connector( CN2 ) for ON/OFF control is provided in the Primary Circuit. When using CN2, safety standard requirements should be considered in application design or choice of switch, relay or connector.

In particular:-

- (1) Basic insulation must be provided between the ON/OFF control circuit and earth.
- (2) Reinforced insulation must be provided between the ON/OFF control circuit and any secondary circuit or accessible part.
- (3) Wiring must be drawn to avoid damage to the insulation of the wire or sleeving.

Terminal condition	Output Condition
Connector(CN2) Short	ON
Connector(CN2) Open	OFF

#### Secondary side

When using Secondary side ON/OFF Control, put off a jumper J1 at CN2. It is controlled by the voltage applied to +R and -R at CN53. This circuit never connect in the Primary ( input ) side. And this circuit is isolated from the output by a photocoupler.

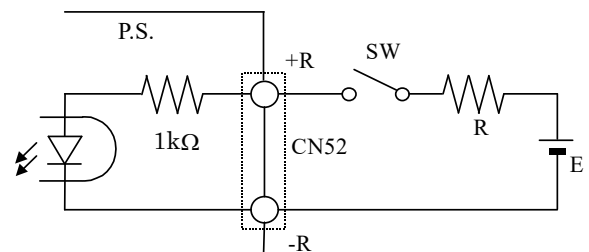

The control mode is shown below.

The control mode is shown below.+ R & - R terminal condition	Output Condition
SW ON ( Higher than 4.5V )	ON
SW OFF ( Lower than 0.8V )	OFF

External voltage level : E	External resistance : R
4.5~12.5VDC	No required
12.5~24.5VDC	1.5kΩ

Input ~ FG ( chassis ) : solid line  
 Input ~ Output : dotted line

## 4. Isolation Test / Withstand Voltage

### 4-1 Isolation Test

Isolation resistance between output and FG ( chassis ) shall be more than 100MΩ at 500VDC. For safety operation, voltage setting of DC isolation tester must be done before the test. Ensure that the unit is fully discharged after the test.

Output ~ FG ( chassis )

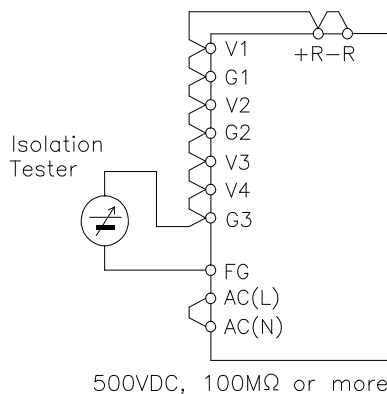

### 4-2. Withstand Voltage

This series is designed to withstand 3.0kVAC between input and output, 2.0kVAC between input and FG ( chassis ) and 500VAC between output and the FG ( chassis ) each for 1 minute. When testing withstand voltage, set current limit of the withstand voltage test equipment to 20mA ( Output - FG ( chassis ) : 100mA ). The applied voltage must be gradually increased from zero to the testing value and then gradually decreased for shut down. When timer is used, the power supply may be damaged by high impulse voltage at timer switch on and off. Connect input and output as follows.

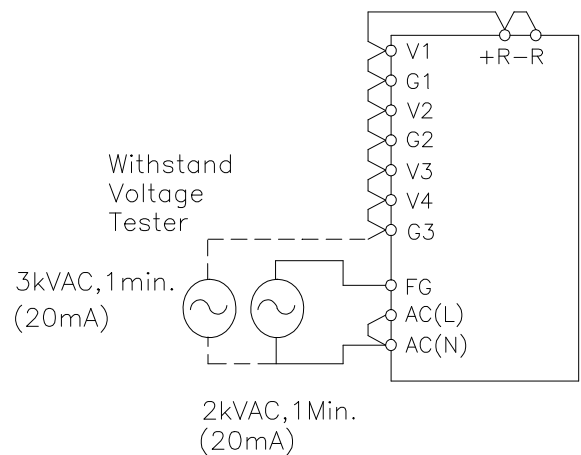

Output ~ FG ( chassis )

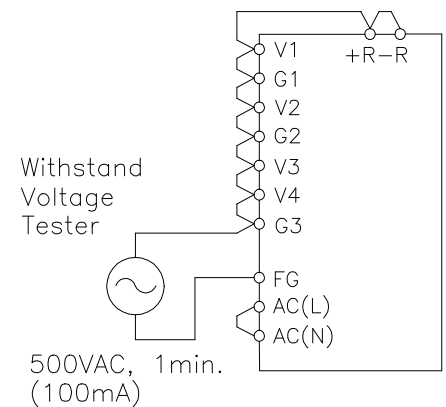



## 5. Mounting Directions

### 5-1. Output Derating according to the Mounting Directions

Recommend standard mounting is method (A). Method (B), (C), (D), (E) are also possible. Refer to the derating below. Please do not use installation method (F), where the PCB will be on the top side and heat will be trapped inside the unit. In the following derating curve, Load (%) is percent of total allowable output power or each maximum output current, whichever is greater.

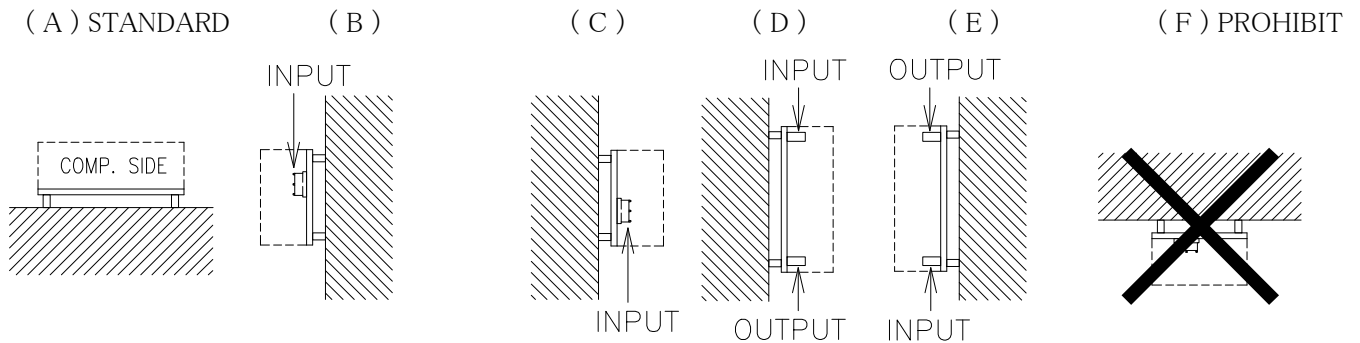

## Output Derating

PCB type and with chassis type  
 ( Convection cooling )

### ZWQ80

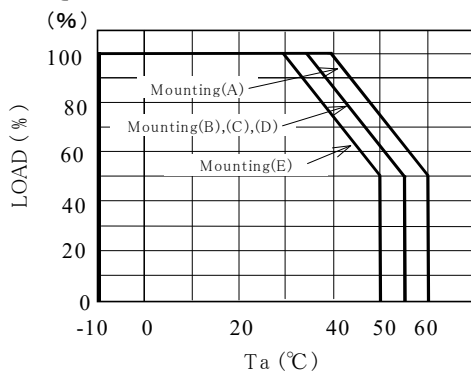

Mounting Ta	LOAD(%)				
	A	B	C	D	E
- 10 ~ 25°C	100	100	100	100	100
30°C	100	100	100	100	100
35°C	100	100	100	100	87
40°C	100	87	87	87	75
45°C	87	75	75	75	62
50°C	75	62	62	62	50
55°C	62	50	50	50	
60°C	50				

(Mounting A)

	Total allowable output power(W)		
	40°C	50°C	60°C
	ZWQ80	80	60

	CH	Output voltage	Each allowable output power(W)			Maximum output current(A)		
		(V)	40°C	50°C	60°C	40°C	50°C	60°C
522*	V1	5	40	30	20	8	6	4
	V2	+12/+15	24/30	18/22.5	12/15	2	1.5	1
	V3	-12/-15	24/30	18/22.5	12/15	2	1.5	1
5223	V4	3.3	23.1	17.3	11.5	7	5.2	3.5
5225	V4	5	35	26.2	17.5	7	5.2	3.5
5222	V4	12	36	27	18	3	2.2	1.5
5224	V4	24	36	27	18	1.5	1.1	0.7

**ZWQ130**

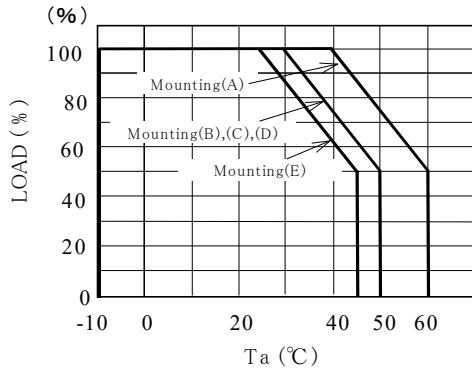

Mounting Ta	LOAD(%)				
	A	B	C	D	E
- 10 ~ 25°C	100	100	100	100	100
30°C	100	100	100	100	87
35°C	100	87	87	87	75
40°C	100	75	75	75	62
45°C	87	62	62	62	50
50°C	75	50	50	50	
55°C	62				
60°C	50				

(Mounting A)

	Total allowable output power(W)		
	40°C	50°C	60°C
ZWQ130	130	97.5	65

	CH	Output voltage (V)	Each allowable output power (W)			Maximum output current(A)		
			40°C	50°C	60°C	40°C	50°C	60°C
522*	V1	5	75	56.2	37.5	15	11.2	7.5
	V2	+12/+15	48/60	36/45	24/30	4	3	2
	V3	-12/-15	48/60	36/45	24/30	4	3	2
5223	V4	3.3	33	24.7	16.5	10	7.5	5
5225	V4	5	50	26.2	25	10	7.5	5
5222	V4	12	48	27	24	4	3	2
5224	V4	24	48	27	24	2	1.5	1

**PCB type, with chassis type**  
**( Forced air cooling )**

**ZWQ80·ZWQ130**

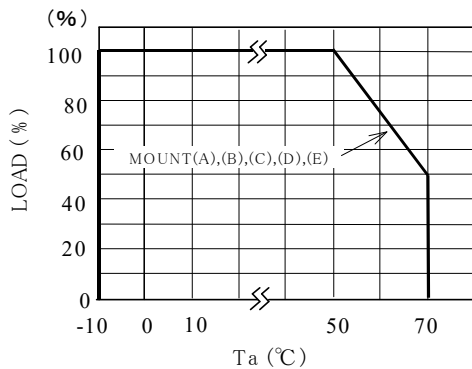

Mounting Ta	LOAD (%)				
	A	B	C	D	E
- 10 ~ 30°C	100	100	100	100	100
35°C	100	100	100	100	100
40°C	100	100	100	100	100
45°C	87	87	87	87	87
50°C	75	75	75	75	75
55°C	62	62	62	62	62
60°C	50	50	50	50	50

(Mounting A)

	Total allowable output power(W)		
	50°C	60°C	70°C
ZWQ80	80	60	40
ZWQ130	130	97.5	65

**ZWQ80 (Mounting A)**

	CH	Output power	Each allowable output power (W)			Maximum output current(A)		
		(V)	50°C	60°C	70°C	50°C	60°C	70°C
522*	V1	5	50	37.5	25	10	7.5	5
	V2	+12/+15	30/37.5	22.5/28.1	15/18.7	2.5	1.8	1.2
	V3	-12/-15	30/37.5	22.5/28.1	15/18.7	2.5	1.8	1.2
5223	V4	3.3	29.7	22.2	14.8	9	6.7	4.5
5225	V4	5	45	33.7	22.5	9	6.7	4.5
5222	V4	12	48	36	24	4	3	2
5224	V4	24	48	36	24	2	1.5	1

**ZWQ130 (Mounting A)**

	CH	Output voltage	Each allowable output power (W)			Maximum output power (A)		
		(V)	50°C	60°C	70°C	50°C	60°C	70°C
522*	V1	5	95	71.2	47.5	19	14.2	9.5
	V2	+12/+15	60/75	45/56.2	30/37.5	5	3.7	2.5
	V3	-12/-15	60/75	45/56.2	30/37.5	5	3.7	2.5
5223	V4	3.3	39.6	29.7	19.8	12	9	6
5225	V4	5	60	45	30	12	9	6
5222	V4	12	60	45	30	5	3.7	2.5
5224	V4	24	60	45	30	2.5	1.8	1.2

\*Please let air ( 0.85m<sup>3</sup>/min ( 30cfm ) ) flow into the Component side.  
 (please make air flow to maintain Core of T1 temperature 80°C.)

**5-2. Output Derating according to the Mounting Directions for with Cover type**

ZWQ series has option that with Cover type ( /A ). Recommend standard mounting is method ( A ). Method ( B ), ( C ), ( D ), ( E ) are also possible. Refer to the derating below. Please do not use installation method ( F ), where the PCB will be on the top side and heat will be trapped inside the unit. In the following derating curve, Load ( % ) is percent of total allowable output power or each maximum output current, whichever is greater.

( A ) STANDARD      ( B )      ( C )      ( D )      ( E )      ( F ) PROHIBIT

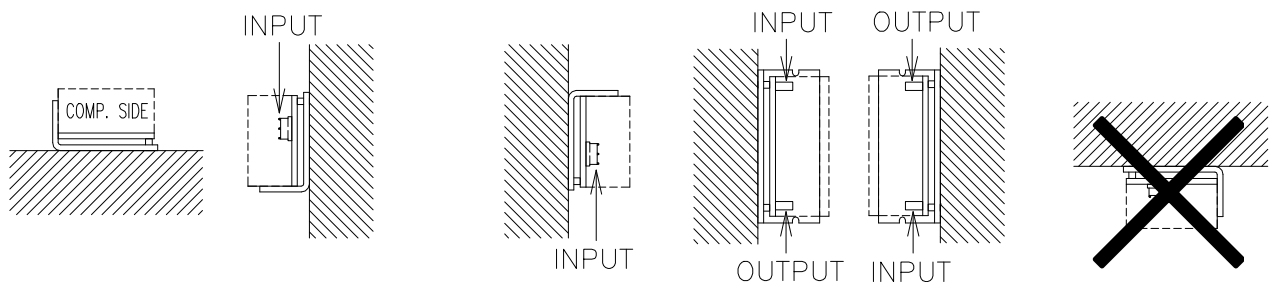

**With Cover ( Convection cooling )**

**ZWQ80/A**

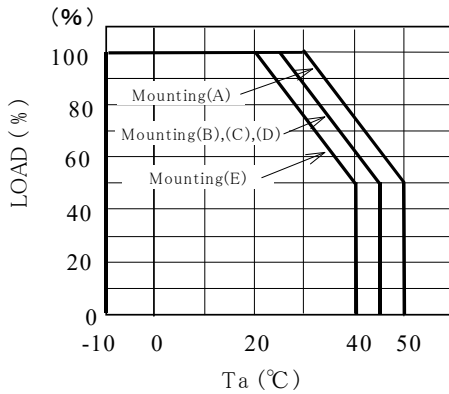

Mounting Ta	LOAD (%)				
	A	B	C	D	E
- 10~ 15°C	100	100	100	100	100
20°C	100	100	100	100	100
25°C	100	100	100	100	87
30°C	100	87	87	87	75
35°C	87	75	75	75	62
40°C	75	62	62	62	50
45°C	62	50	50	50	
50°C	50				

(Mounting A)

	Total allowable output power(W)		
	40°C	50°C	60°C
ZWQ80/A	80	60	40

	CH	Output voltage (V)	Each allowable output power (W)			Maximum output current (A)		
			30°C	40°C	50°C	30°C	40°C	50°C
522*	V1	5	40	30	20	8	6	4
	V2	+12/+15	24/30	18/22.5	12/15	2	1.5	1
	V3	-12/-15	24/30	18/22.5	12/15	2	1.5	1
5223	V4	3.3	23.1	17.3	11.5	7	5.2	3.5
5225	V4	5	35	26.2	17.5	7	5.2	3.5
5222	V4	12	36	27	18	3	2.2	1.5
5224	V4	24	36	27	18	1.5	1.1	0.7

**ZWQ130/A**

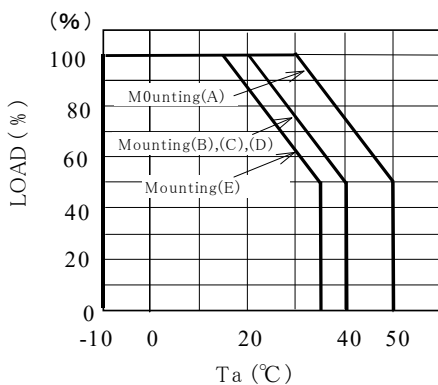

Mounting Ta	LOAD (%)				
	A	B	C	D	E
- 10~ 15°C	100	100	100	100	100
20°C	100	100	100	100	87
25°C	100	87	87	87	75
30°C	100	75	75	75	62
35°C	87	62	62	62	50
40°C	75	50	50	50	
45°C	62				
50°C	50				

(Mounting A)

	Total allowable output power(W)		
	30°C	40°C	50°C
ZWQ130/A	130	97.5	65

	CH	Output voltage	Each allowable output power (W)			Maximum output current(A)		
		(V)	30°C	40°C	50°C	30°C	40°C	50°C
522*	V1	5	75	56.2	37.5	15	11.2	7.5
	V2	+12/+15	48/60	36/45	24/30	4	3	2
	V3	-12/-15	48/60	36/45	24/30	4	3	2
5223	V4	3.3	33	24.7	16.5	10	7.5	5
5225	V4	5	50	26.2	25	10	7.5	5
5222	V4	12	48	27	24	4	3	2
5224	V4	24	48	27	24	2	1.5	1

**With Cover ( Forced air cooling )**

**ZWQ80/A·ZWQ130/A**

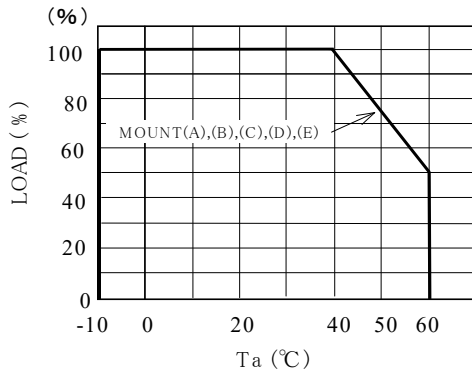

Ta \ Mounting	LOAD (%)				
	A	B	C	D	E
- 10 ~ 30°C	100	100	100	100	100
35°C	100	100	100	100	100
40°C	100	100	100	100	100
45°C	87	87	87	87	87
50°C	75	75	75	75	75
55°C	62	62	62	62	62
60°C	50	50	50	50	50

(Mounting A)

	Total allowable output power(W)		
	40°C	50°C	60°C
ZWQ80/A	80	60	40
ZWQ130/A	130	97.5	65

**ZWQ80/A (Mounting A)**

	CH	Output voltage	Each allowable output power(W)			Maximum output current (A)		
		(V)	40°C	50°C	60°C	40°C	50°C	60°C
522*	V1	5	50	37.5	25	10	7.5	5
	V2	+12/+15	30/37.5	22.5/28.1	15/18.7	2.5	1.8	1.2
	V3	-12/-15	30/37.5	22.5/28.1	15/18.7	2.5	1.8	1.2
5223	V4	3.3	29.7	22.2	14.8	9	6.7	4.5
5225	V4	5	45	33.7	22.5	9	6.7	4.5
5222	V4	12	48	36	24	4	3	2
5224	V4	24	48	36	24	2	1.5	1

**ZWQ130/A (Mounting A)**

	CH	Output voltage	Each allowable output power(A)			Muximum output current (A)		
		(V)	40°C	50°C	60°C	40°C	50°C	60°C
522*	V1	5	95	71.2	47.5	19	14.2	9.5
	V2	+12V/+15	60/75	45/56.2	30/37.5	5	3.7	2.5
	V3	-12V/-15	60/75	45/56.2	30/37.5	5	3.7	2.5
5223	V4	3.3	39.6	29.7	19.8	12	9	6
5225	V4	5	60	45	30	12	9	6
5222	V4	12	60	45	30	5	3.7	2.5
5224	V4	24	60	45	30	2.5	1.8	1.2

\*Please let air ( 0.85m<sup>3</sup>/min ( 30cfm ) ) flow into the Component side.  
 (please make air flow to maintain Core of T1 temperature 80°C.)

## 5-2. Mounting Method

### PCB type

Please use the mounting hole as:

ZWQ80 : 5 holes of  $\phi 3.5$

ZWQ130 : 4 holes of  $\phi 3.5$

and insert the spacer (MAX  $\phi 6.0$ ) of height over 8mm to lift the unit. Also use all mounting holes for the unit installation. The vibration spec is the value when the unit is raised by 8mm spacers.

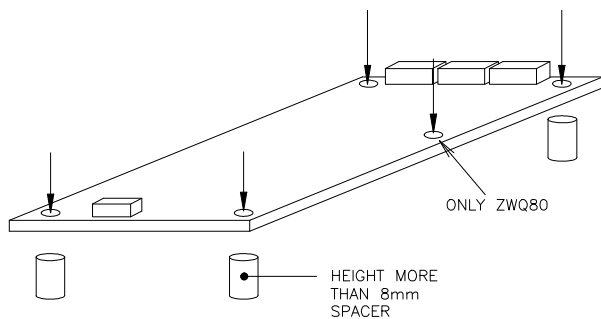

And allowable area by metal pieces is 9mm from each PCB corners. Refer to figure below.

### ZWQ80

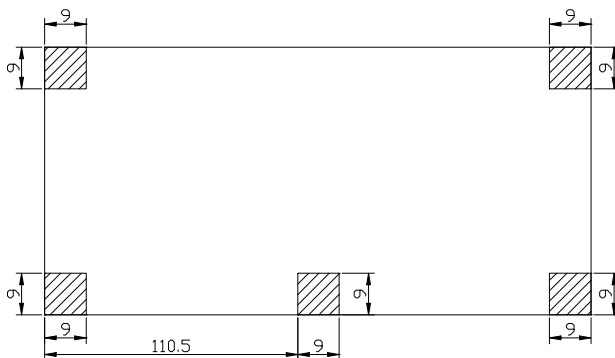

### ZWQ130



Please leave 5mm space from the surfaces and left 4mm space from the sides of PCB, especially from the solder surface, 8mm space is necessary. If the space is not enough, the specification of insulation and withstand will not be satisfied.

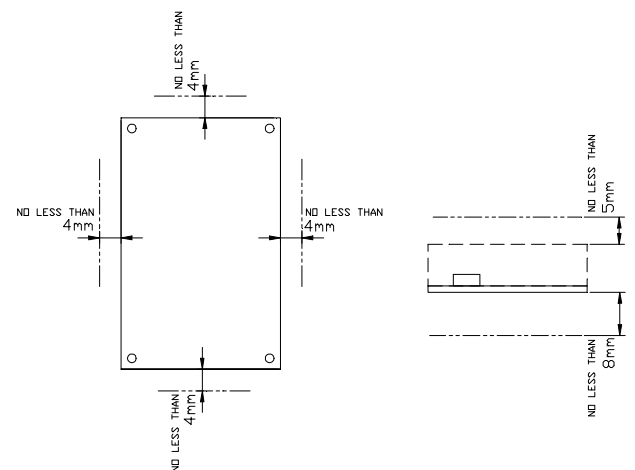

FG should be connected to the earth terminal of the apparatus. If not, the conducted noise and output noise will increase.

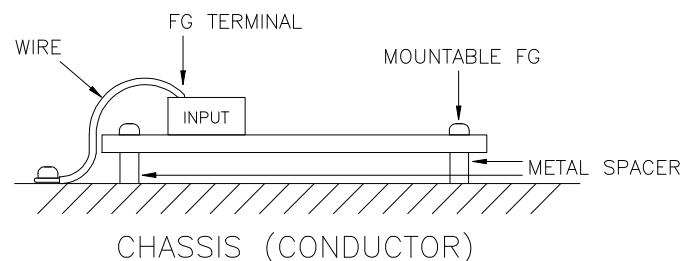

Hatching area is maximum permissible of metal part for mounting.

### With chassis

- (1) In the consideration for the heat radiation and safety when the power supply is used on condition that convection cooling. Please take a distance more than 15mm between the power supply and the peripheral parts. When lining up multiple units, please make sure to place them 15mm or more apart from each other.
- (2) The maximum allowable penetration of mounting screws is 6mm.
- (3) Recommended torque for mounting screw.

M4 screw : 1.27 N·m ( 13.0 kgf·cm )

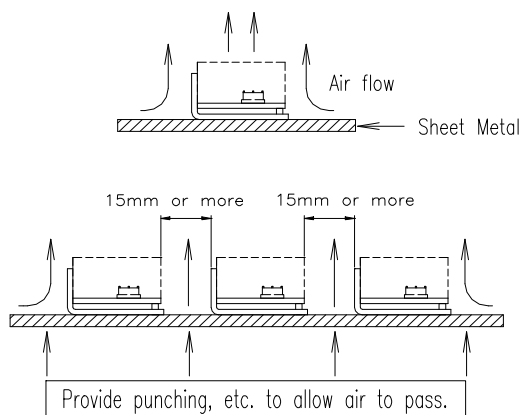

### 6. Wiring Method

- The output load line and input line shall be separated and twisted to improve noise sensitivity.
- Use all lines as thick and short as possible to make lower impedance.
- Noise can be eliminated by attaching a capacitor to the load terminals.
- For safety and EMI considerations, connect FG terminal of input connector and mountable FG of ZWQ series to mounting set ground terminal at equipment.
- Select the wire materials to adapt the connector as follow.

INPUT ; ZWQ80/130 ..... AWG#22-#18  
 OUTPUT; ZWQ80/130 ..... AWG#22-#18

### 7. External Fuse Rating

Refer to the following fuse rating when selecting the external fuses that are to be used on input line. Surge current flows when line turns on. Use slow-blow fuse or time-lag type fuse. Do not use fast-blow fuse. Fuse rating is specified by in-rush current value at line turn-on. Do not select the fuse according to input current (rms.) values under the actual load condition.

ZWQ80 : 3.15A  
 ZWQ130 : 5.0A

### 8. Before concluding that the unit is at fault...

Before concluding that the unit is at fault, make the following checks.

- Check if the rated input voltage is connected.
- Check if the wiring of input and output is correct.
- Check if the wire material is not too thin.
- Check if the output voltage control ( V.ADJ ) is properly adjusted.
- If you use function of the Remote ON/OFF control, Check if the Remote ON/OFF control connector is not opened.
- Check if the output current and output wattage dose not over specification.
- Check if the output current of CH1 is more than 12% of maximum output current.
- Audible noise can be heard during Dynamic-Load operation.
- Audible noise can be heard when input voltage waveform is not sinusoidal wave.

### 9. Notes

- 1) Over voltage Category II.
- 2) Radio Interference Suppression Test is not performed.

### 10. REPAIR

In case of damage or repair of this product, please return to our service center or factory.



## **11. CE MARKING/UKCA MARKING**

### **CE MARKING**

CE Marking, when applied to a product or packing material for a product covered by this handbook, indicates compliance with the Low Voltage Directive and RoHS Directive.

### **UKCA MARKING**

UKCA Marking, when applied to a product or packing material for a product covered by this handbook, indicates compliance with the Electrical Equipment (Safety) Regulations and Restriction of the Use of Certain Hazardous Substances in Electrical & Electronic Equipment Regulations.