

18 CKT PART SHOWN

- NOTES:**
- HOUSING MATERIAL: A = NYLON 6/6. U.L. 94V-2. COLOR: NATURAL.
B = NYLON 6/6. U.L. 94V-0. COLOR: NATURAL.
C = PBT POLYESTER 94V-0 COLOR: BLACK
 - TERMINAL MATERIAL: BRASS ALLOY
 - TERMINAL PLATING
A = .000100/(.00254) MIN. MATTE TIN OVER
.000050/(.00127) MIN. NICKEL.
C = .000030/(0.00076) MIN. SELECT GOLD AND
.000100/(0.00254) MIN. SELECT MATTE TIN
OVER .000050/(0.00127) MIN. NICKEL OVERALL
D = .000060/(0.00152) MIN REFLOWED MATTE TIN OVER
.000050/(0.00127) MIN. NICKEL OVERALL.
 - PRODUCT SPECIFICATION: PS-5556-002
 - PACKAGING IN TRAYS PER PK-42404-002 EXCEPT 43693-0024 PACKAGED BULK
 - PART MATES WITH MINI-FIT JR. RECEPTACLES 5557, 42385, 42474 AND 44516.
 - PART ALLOWS FOR UP TO .100(2.54) MISALIGNMENT WITH MATING RECEPTACLE IN ANY DIRECTION. SEE MATING CONNECTOR DRAWINGS FOR SPECIFIC ALLOWANCE.
 - PARTS ARE NOT DESIGNED FOR CURRENT SHARING.
 - CONNECTORS ASSEMBLIES ARE NOT TO BE MATED OR UNMATED WHILE CIRCUITS ARE LIVE.
 - SEE CHART ON SHEET 2 FOR STANDARD, MAKE-FIRST/BREAK-LAST AND PLATING LOCATIONS.
 - ITEM NUMBERS PRECEDED BY AN "X" IN THE CHART ARE NOT AVAILABLE.
 - REFERENCE DIMENSION "C" NOT TO EXCEED .283(7.20) NOMINAL.
 - DISCOLORATION IN THE BANDOLIER CARRIER AREA OF THE PIN IS INHERENT TO THE PLATING PROCESS AND IS DUE TO THE MASKING EFFECT OF THE CARRIER. THIS DISCOLORATION IS IN A NON-FUNCTIONAL AREA OF THE PIN AND WILL NOT AFFECT THE PERFORMANCE OF THE HEADER ASSEMBLY.
 - PART CONFORMS TO CLASS "B" REQUIREMENTS OF COSMETIC SPECIFICATION PS-45499-002, EXCEPT CLASS "C" ON BOTH SIDE RIBS.
 - CUT OFF PEGS NOT TO PROTRUDE MORE THAN .030(0.76) ON ALL CIRCUIT SIZES EXCEPT 18 CIRCUIT PARTS WILL NOT HAVE CUT OFF PEGS.

| | | |
|-----------|------------------|------------------|
| 36 | 2.811 (71.40) | 3.236 (82.20) |
| 24 | 1.819 (46.20) | 2.244 (57.00) |
| 22 | 1.654 (42.00) | 2.079 (52.80) |
| 20 | 1.488 (37.80) | 1.913 (48.60) |
| 18 | 1.323 (33.60) | 1.748 (44.40) |
| 16 | 1.157 (29.40) | 1.583 (40.20) |
| 14 | .992 (25.20) | 1.417 (36.00) |
| 12 | .827 (21.00) | 1.252 (31.80) |
| 10 | .661 (16.80) | 1.087 (27.60) |
| 8 | .496 (12.60) | .921 (23.40) |
| 6 | .331 (8.40) | .756 (19.20) |
| 4 | .165 (4.20) | .590 (15.00) |
| 2 | — | .425 (10.80) |
| CKT. SIZE | DIM. "A" | DIM. "B" |

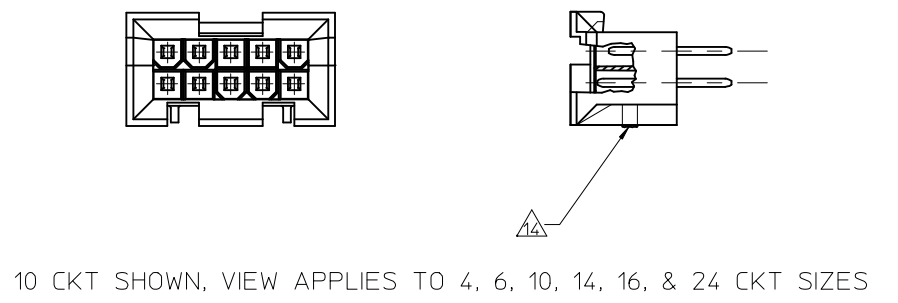
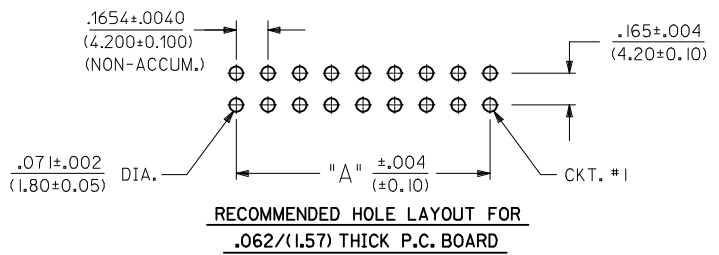

| | | | |
|--|--|--------------------|--------------------------------------|
| UPDATE NOTE 14 EC NO: UCP2015-4258 DRWN: JONT CHKD: JBELL APPR: FSMITH | 2015/06/25 2015/06/25 2015/07/10 | DESCRIPTION REV | QUALITY SYMBOLS ▽=0 ▽=0 ▽=0 |
|--|--|--------------------|--------------------------------------|

| | | | | |
|---------------------------------------|-----------------------|---|-----------------------------|------------------------------|
| GENERAL TOLERANCES (UNLESS SPECIFIED) | DIMENSION STYLE IN/MM | SCALE 2:1 | DESIGN UNITS METRIC | THIRD ANGLE PROJECTION |
| 4 PLACES ± --- ± --- | mm INCH | DRAWN BY GEP DATE 3/11/96 | CHECKED BY RFJ DATE 3/11/96 | APPROVED BY RFJ DATE 3/11/96 |
| 3 PLACES ± --- ± .015 | | MATERIAL NO. SEE CHART | | |
| 2 PLACES ± 0.38 ± --- | | DOCUMENT NO. SDA-43693-**** | | |
| 1 PLACE ± --- ± --- | | SHEET NO. 1 OF 2 | | |
| ANGULAR ±1/2° | | THIS DRAWING CONTAINS INFORMATION THAT IS PROPRIETARY TO MOLEX INCORPORATED AND SHOULD NOT BE USED WITHOUT WRITTEN PERMISSION | | |

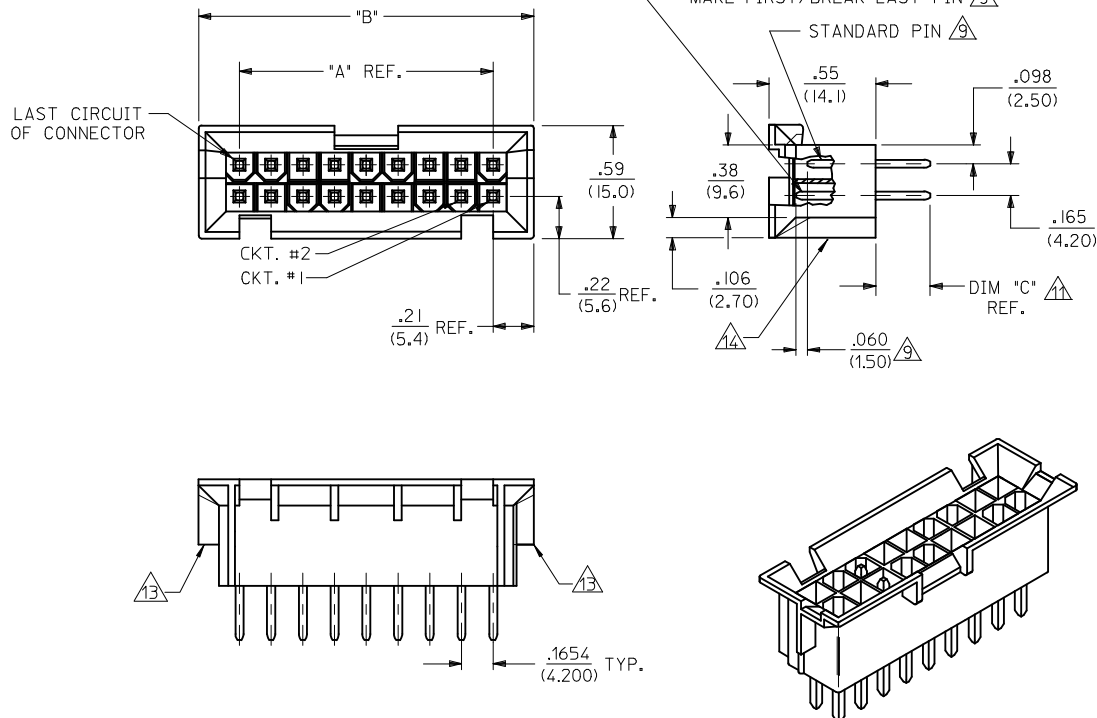

18 CKT PART SHOWN

- NOTES:**
- HOUSING MATERIAL: A = NYLON 6/6. U.L. 94V-2. COLOR: NATURAL.
B = NYLON 6/6. U.L. 94V-0. COLOR: NATURAL.
C = PBT POLYESTER 94V-0 COLOR: BLACK
 - TERMINAL MATERIAL: BRASS ALLOY
 - TERMINAL PLATING
A = .000100/(.00254) MIN. MATTE TIN OVER
.000050/(.00127) MIN. NICKEL.
C = .000030/(0.00076) MIN. SELECT GOLD AND
.000100/(0.00254) MIN. SELECT MATTE TIN
OVER .000050/(0.00127) MIN. NICKEL OVERALL
D = .000060/(0.00152) MIN REFLOWED MATTE TIN OVER
.000050/(0.00127) MIN. NICKEL OVERALL.
 - PRODUCT SPECIFICATION: PS-5556-002
 - PACKAGING IN TRAYS PER PK-42404-002 EXCEPT 43693-0024 PACKAGED BULK
 - PART MATES WITH MINI-FIT JR. RECEPTACLES 5557, 42385, 42474 AND 44516.
 - PART ALLOWS FOR UP TO .100(2.54) MISALIGNMENT WITH MATING RECEPTACLE IN ANY DIRECTION. SEE MATING CONNECTOR DRAWINGS FOR SPECIFIC ALLOWANCE.
 - PARTS ARE NOT DESIGNED FOR CURRENT SHARING.
 - CONNECTORS ASSEMBLIES ARE NOT TO BE MATED OR UNMATED WHILE CIRCUITS ARE LIVE.
 - SEE CHART ON SHEET 2 FOR STANDARD, MAKE-FIRST/BREAK-LAST AND PLATING LOCATIONS.
 - ITEM NUMBERS PRECEDED BY AN "X" IN THE CHART ARE NOT AVAILABLE.
 - REFERENCE DIMENSION "C" NOT TO EXCEED .283(7.20) NOMINAL.
 - DISCOLORATION IN THE BANDOLIER CARRIER AREA OF THE PIN IS INHERENT TO THE PLATING PROCESS AND IS DUE TO THE MASKING EFFECT OF THE CARRIER. THIS DISCOLORATION IS IN A NON-FUNCTIONAL AREA OF THE PIN AND WILL NOT AFFECT THE PERFORMANCE OF THE HEADER ASSEMBLY.
 - PART CONFORMS TO CLASS "B" REQUIREMENTS OF COSMETIC SPECIFICATION PS-45499-002, EXCEPT CLASS "C" ON BOTH SIDE RIBS.
 - CUT OFF PEGS NOT TO PROTRUDE MORE THAN .030(0.76) ON ALL CIRCUIT SIZES EXCEPT 18 CIRCUIT PARTS WILL NOT HAVE CUT OFF PEGS.

| | | |
|-----------|------------------|------------------|
| 36 | 2.811 (71.40) | 3.236 (82.20) |
| 24 | 1.819 (46.20) | 2.244 (57.00) |
| 22 | 1.654 (42.00) | 2.079 (52.80) |
| 20 | 1.488 (37.80) | 1.913 (48.60) |
| 18 | 1.323 (33.60) | 1.748 (44.40) |
| 16 | 1.157 (29.40) | 1.583 (40.20) |
| 14 | .992 (25.20) | 1.417 (36.00) |
| 12 | .827 (21.00) | 1.252 (31.80) |
| 10 | .661 (16.80) | 1.087 (27.60) |
| 8 | .496 (12.60) | .921 (23.40) |
| 6 | .331 (8.40) | .756 (19.20) |
| 4 | .165 (4.20) | .590 (15.00) |
| 2 | — | .425 (10.80) |
| CKT. SIZE | DIM. "A" | DIM. "B" |

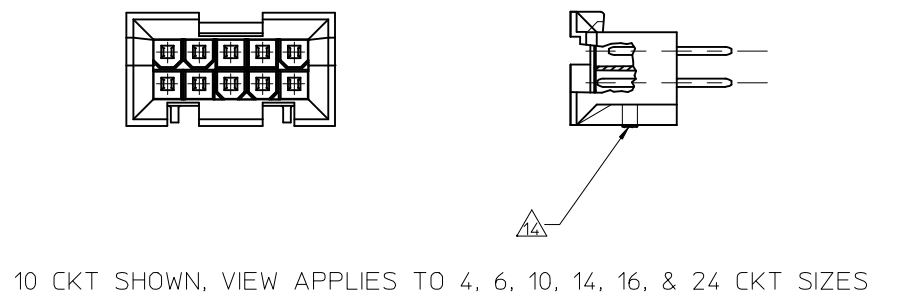
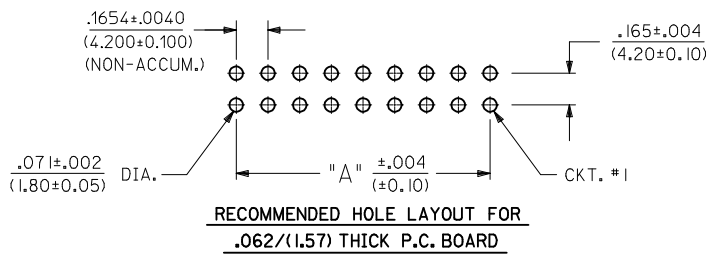

| | | | |
|--|--|--------------------|--------------------------------------|
| UPDATE NOTE 14 EC NO: UCP2015-4258 DRWN: JONT CHKD: JBELL APPR: FSMITH | 2015/06/25 2015/06/25 2015/07/10 | DESCRIPTION REV | QUALITY SYMBOLS ▽=0 ▽=0 ▽=0 |
|--|--|--------------------|--------------------------------------|

| | | | | |
|---------------------------------------|-----------------------|---|-----------------------------|------------------------------|
| GENERAL TOLERANCES (UNLESS SPECIFIED) | DIMENSION STYLE IN/MM | SCALE 2:1 | DESIGN UNITS METRIC | THIRD ANGLE PROJECTION |
| 4 PLACES ± --- ± --- | mm INCH | DRAWN BY GEP DATE 3/11/96 | CHECKED BY RFJ DATE 3/11/96 | APPROVED BY RFJ DATE 3/11/96 |
| 3 PLACES ± --- ± .015 | | MATERIAL NO. SEE CHART | | |
| 2 PLACES ± 0.38 ± --- | | DOCUMENT NO. SDA-43693-**** | | |
| 1 PLACE ± --- ± --- | | SHEET NO. 1 OF 2 | | |
| ANGULAR ±1/2° | | THIS DRAWING CONTAINS INFORMATION THAT IS PROPRIETARY TO MOLEX INCORPORATED AND SHOULD NOT BE USED WITHOUT WRITTEN PERMISSION | | |

