

HI0805P101R-10

PHYSICAL DIMENSIONS:

| | | |
|---|-------------|---------------|
| A | 2.00 [.079] | + 0.20 [.008] |
| B | 1.25 [.049] | + 0.20 [.008] |
| C | 0.90 [.035] | + 0.20 [.008] |
| D | 0.51 [.020] | + 0.25 [.010] |

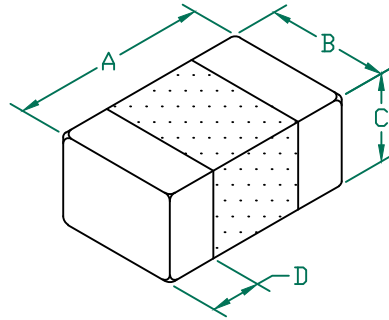

| ELECTRICAL CHARACTERISTICS: | | |
|-----------------------------|---------------------|---------------|
| Z @ 100MHz (Ω) | DCR (Ω) | Rated Current |
| Nominal | 100 | |
| Minimum | 75 | |
| Maximum | 125 | 4000 mA |

- NOTES: UNLESS OTHERWISE SPECIFIED
1. TAPED AND REELED per CURRENT EIA SPECIFICATIONS 7" REELS, 4000 PCS/REEL, PAPER TAPER.
 2. COMPONENTS SHOULD BE ADEQUATELY PREHEATED BEFORE SOLDERING.
 3. TERMINATION FINISH IS 100% TIN.
 4. OPERATING TEMPERATURE: $-40^{\circ}\text{C} \sim +125^{\circ}\text{C}$.
 5. COSMETIC SPECIFICATION REFER TO WI-QA-124.

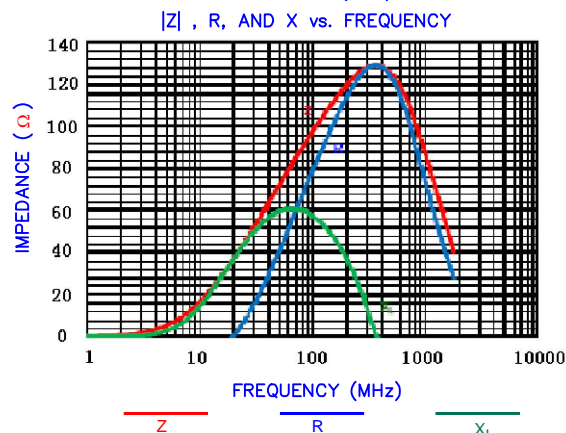
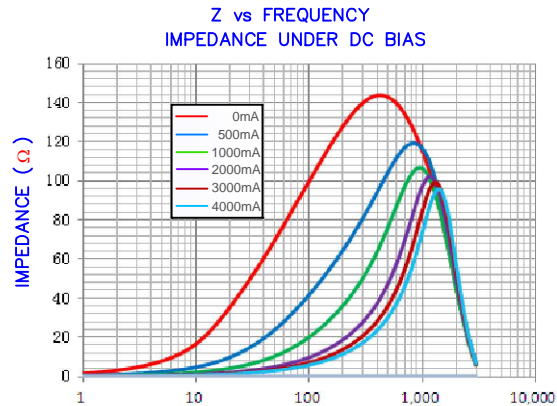

LAND PATTERNS FOR REFLOW SOLDERING

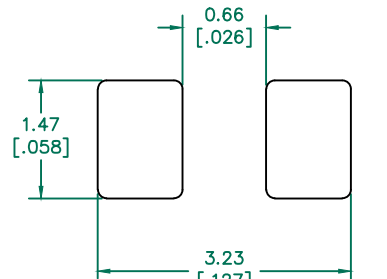

(For wave soldering, add 0.763 [.030] to this dimension.)

RECOMMENDED SOLDERING CONDITIONS

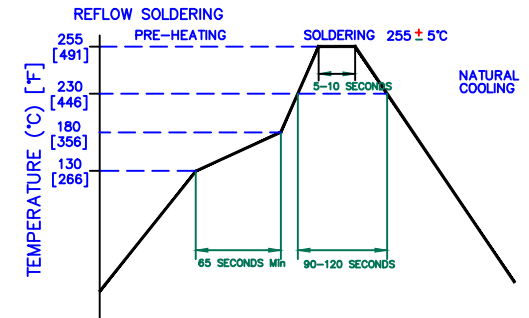

AGILENT E4991A RF Impedance/Material Analyzer
AGILENT 16194A Test



| DIMENSIONS ARE IN mm [INCHES] | | | | This print is the property of Laird Tech. and is loaned in confidence subject to return upon request and with the understanding that no copies shall be made without the written consent of Laird Tech. All rights to design or invention are reserved. | | Laird | |
|--|----------------|----------|-----|---|-----------------------|-----------------|--|
| PROJECT/PART NUMBER: HI0805P101R-10 | | | | REV: A | PART TYPE: CO-FIRE | DRAWN BY: QU | |
| DATE: 08/02/13 | | | | SCALE: NTS | SHEET: 1 of 1 | | |
| REV | DESCRIPTION | DATE | INT | CAD # | TOOL # | | |
| A | ORIGINAL DRAFT | 08/02/13 | QU | HI0805P101R-10-A | | | |