

# BASE CAGE DETAILS

1000171242  
SHOWN

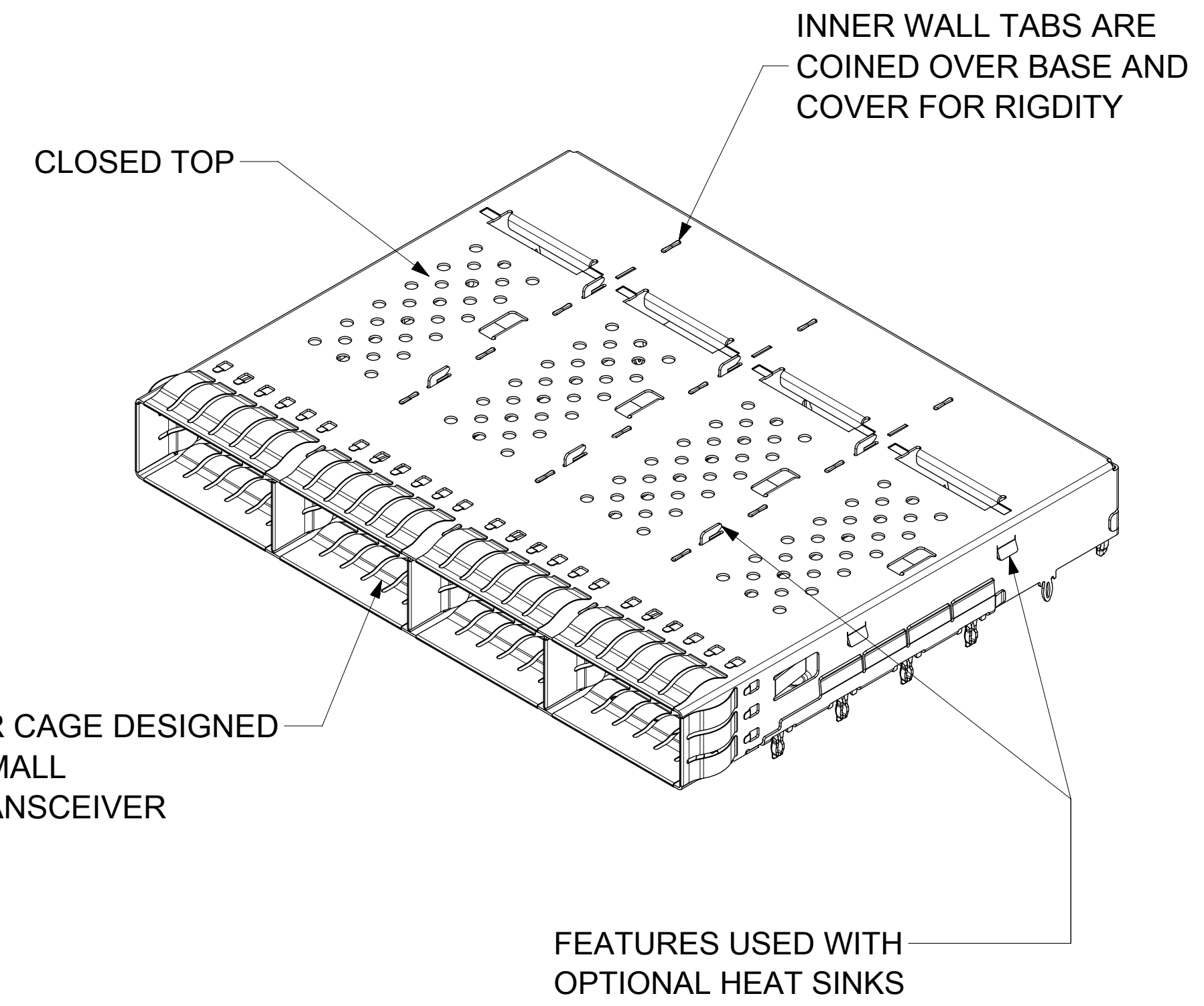

DIMENSIONS OF EACH INNER CAGE DESIGNED TO FUNCTION WITH QUAD SMALL FORM-FACTOR (zQSFP+) TRANSCEIVER

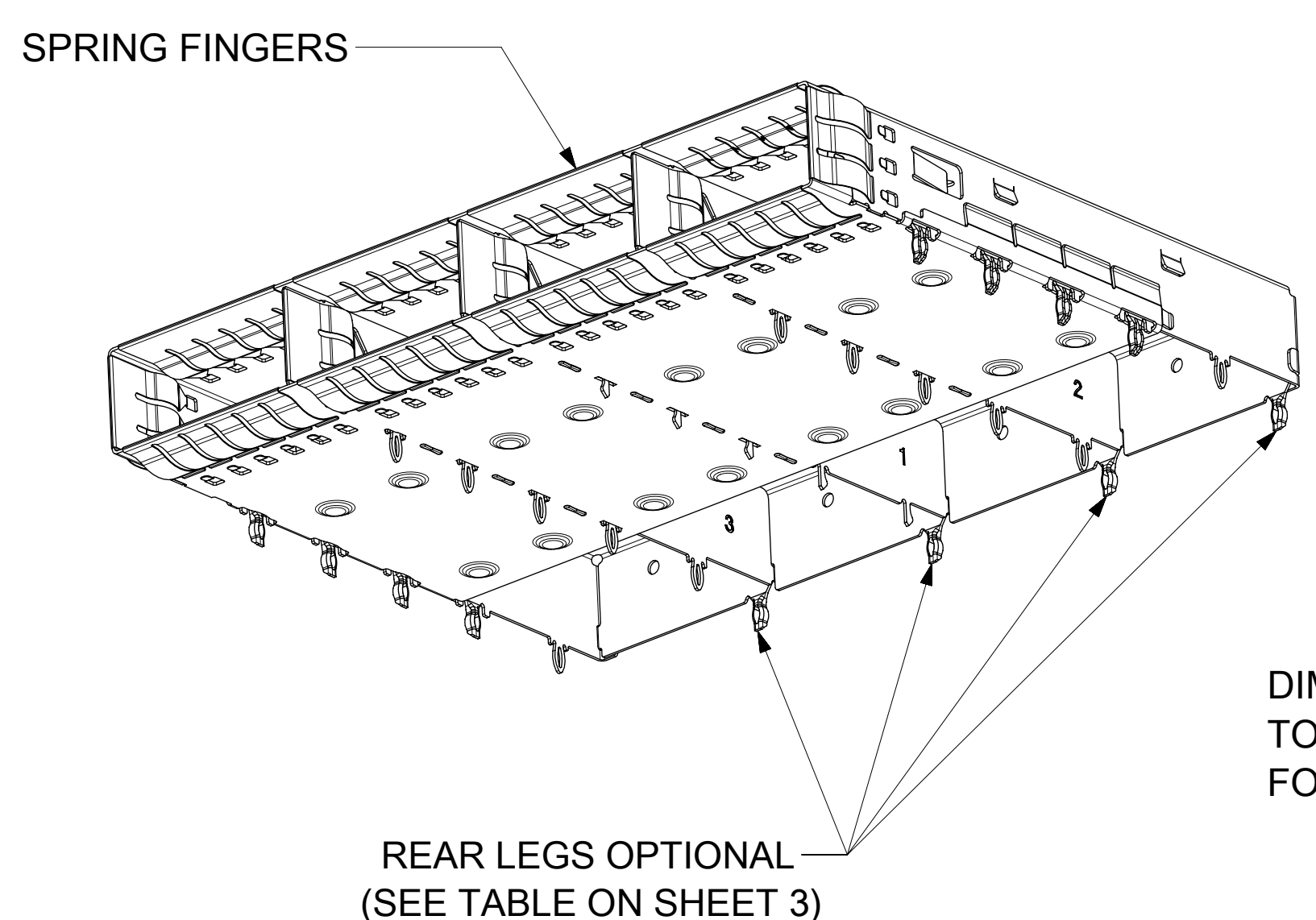
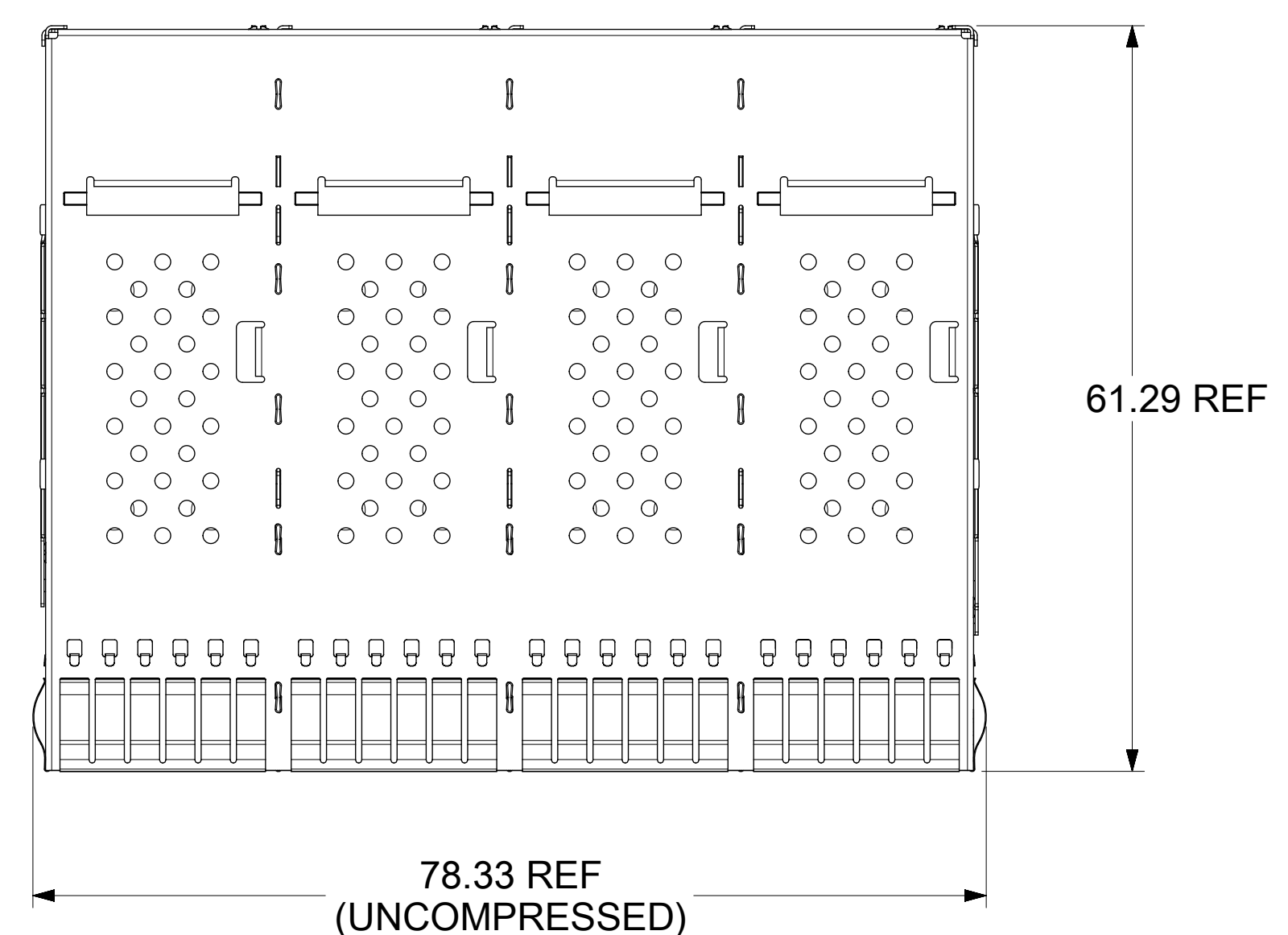
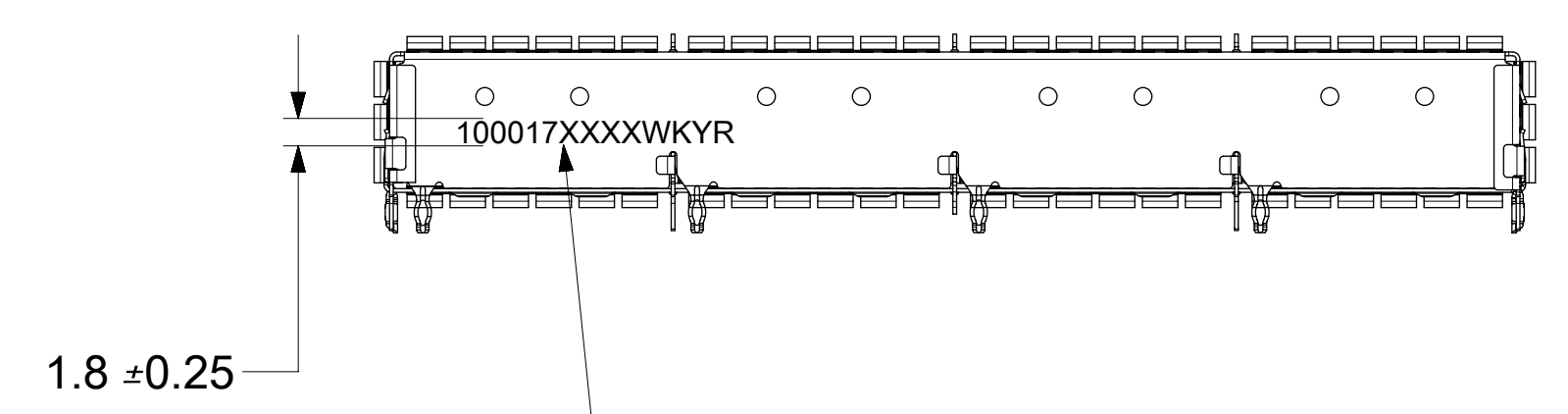
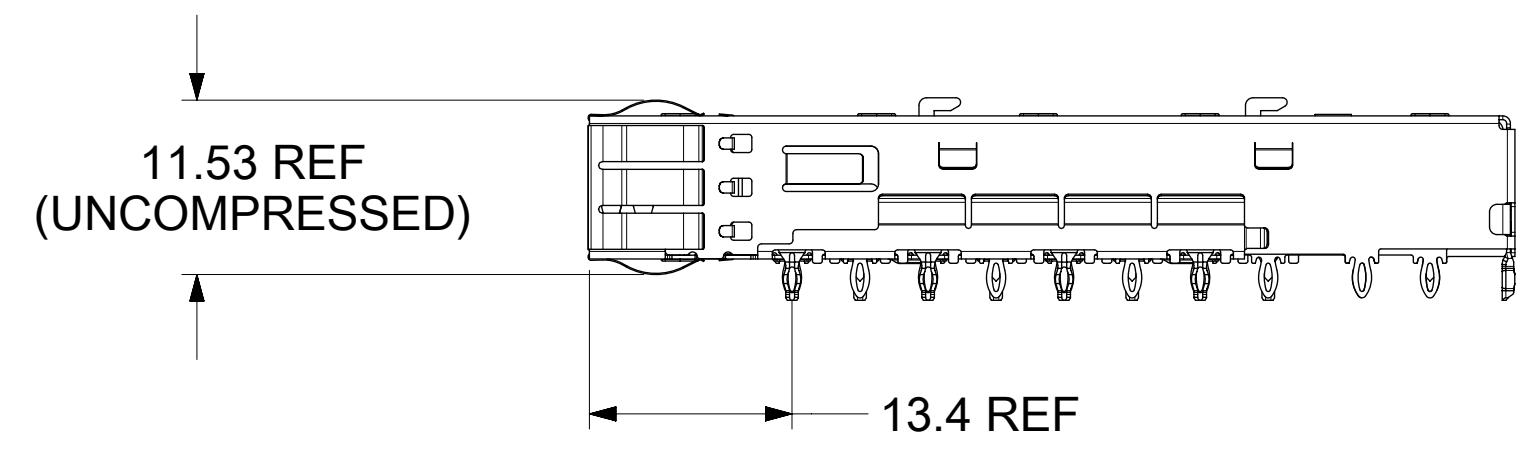
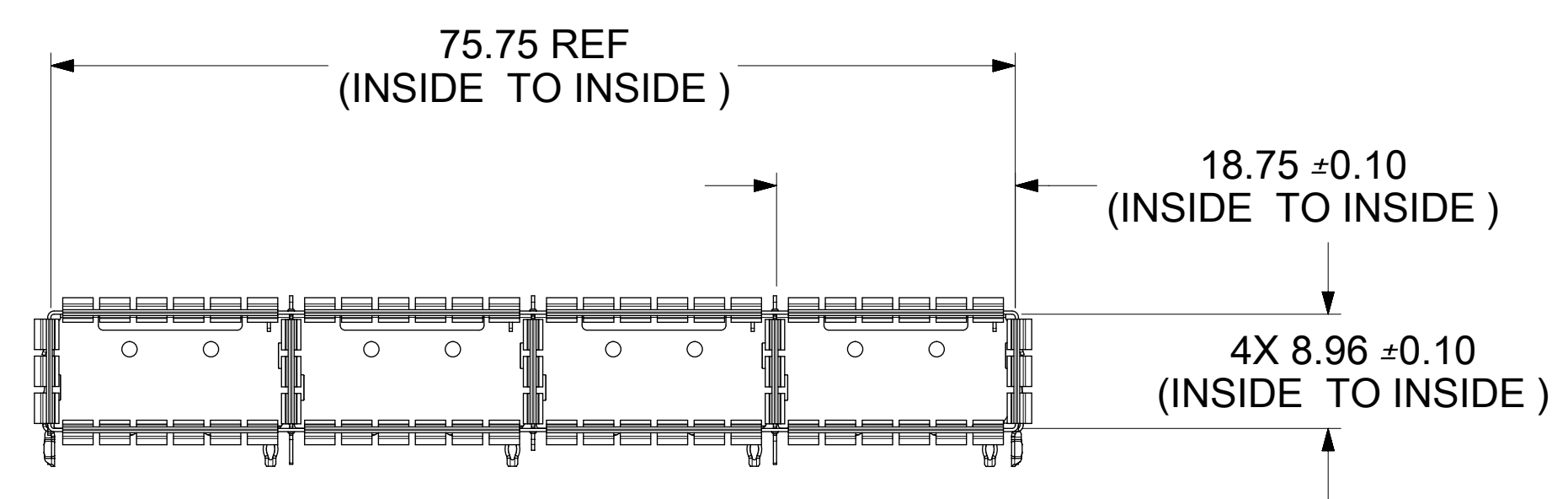

P/N AND WEEK/YEAR DATE CODE TO BE PRINTED ON BACK OF COMPLETED CAGE ASSEMBLY APPROXIMATELY AS SHOWN. SEE TABLE BELOW FOR DATE CODE INFORMATION.

- NOTES:**
- MATERIAL: CAGE: STAINLESS STEEL  
CENTER WALLS: STAINLESS STEEL  
SPRING FINGERS: BERYLLIUM COPPER; NICKEL PLATED  
HEAT SINKS: NICKEL PLATED ALUMINUM  
HEAT SINK CLIP: STAINLESS STEEL  
LIGHT PIPES: POLYCARBONATE (UL 94-V-0)
  - DIMENSIONS MARKED  $\nabla$  ARE CRITICAL TO FUNCTION OF THE PART AND MUST BE INSPECTED
  - DRAWING APPLIES TO ALL P/N'S SHOWN ON PAGE 3
  - DURING FINAL INSPECTION, CAGE LEG LOCATIONS AND STRAIGHTNESS MUST BE CHECKED USING APPROPRIATE GO - NO GO GAGE
  - DURING FINAL INSPECTION, CAGE MUST BE INSPECTED TO MAKE SURE LEG CONFIGURATIONS AND PART NUMBERS ARE CORRECT, USE SHEETS 3, 4 AND 5
  - PARTS TO BE INSPECTED PER MOLEX COSMETIC SPEC WI-HP-7-2774 (CLASS B UNLESS OTHERWISE SPECIFIED)
  - PRESS-FIT LEGS 2.44 LONG -  
1.57 MINIMUM PCB THICKNESS FOR SINGLE SIDED USE.  
3.00 MINIMUM PCB THICKNESS FOR BELLY TO BELLY USE.
  - NO RoHS EXEMPTIONS

WEEK/YEAR DATE CODE TABLE	
WK	WEEK OF THE YEAR 01 THRU 52 (EXAMPLE: 01= FIRST WEEK OF YEAR 52= LAST WEEK OF YEAR)
YR	18, 19, 20 ETC.. (EXAMPLE: YEAR 2018= 18)

THIS DRAWING CONTAINS INFORMATION THAT IS PROPRIETARY TO MOLEX ELECTRONIC TECHNOLOGIES, LLC AND SHOULD NOT BE USED WITHOUT WRITTEN PERMISSION											
DIMENSION UNITS: mm		SCALE: 2:1		CURRENT REV DESC: REACTIVATED PART NUMBER							
GENERAL TOLERANCES (UNLESS SPECIFIED)				<p><b>molex</b></p> <p>ZQSFP+ 1X4 GANGED CAGE ASSY'S (SPRING FINGER) WITH H/S &amp; L/P OPTIONS</p> <p>PRODUCT CUSTOMER DRAWING</p>							
ANGULAR TOL ± 1.0°											
4 PLACES ±		EC NO: 643481									
3 PLACES ±		DRWN: AKUMAR19 2020/08/17									
2 PLACES ± 0.13		CHK'D: GB 2020/08/25									
1 PLACE ± 0.25		APPR: GB 2020/08/25		INITIAL REVISION:				DOCUMENT NUMBER			
0 PLACES ±		DRWN: KNAGANNA 2015/06/03		1000171200				PSD		SD	
DRAFT WHERE APPLICABLE MUST REMAIN WITHIN DIMENSIONS		THIRD ANGLE PROJECTION		DRAWING: D-SIZE		SERIES: 100017		MATERIAL NUMBER: SEE TABLE		CUSTOMER: GENERAL MARKET	
										REVISION: L	
										SHEET NUMBER: 1 OF 9	

# CAGE ASSEMBLY OPTIONS

1000171544

SHOWN

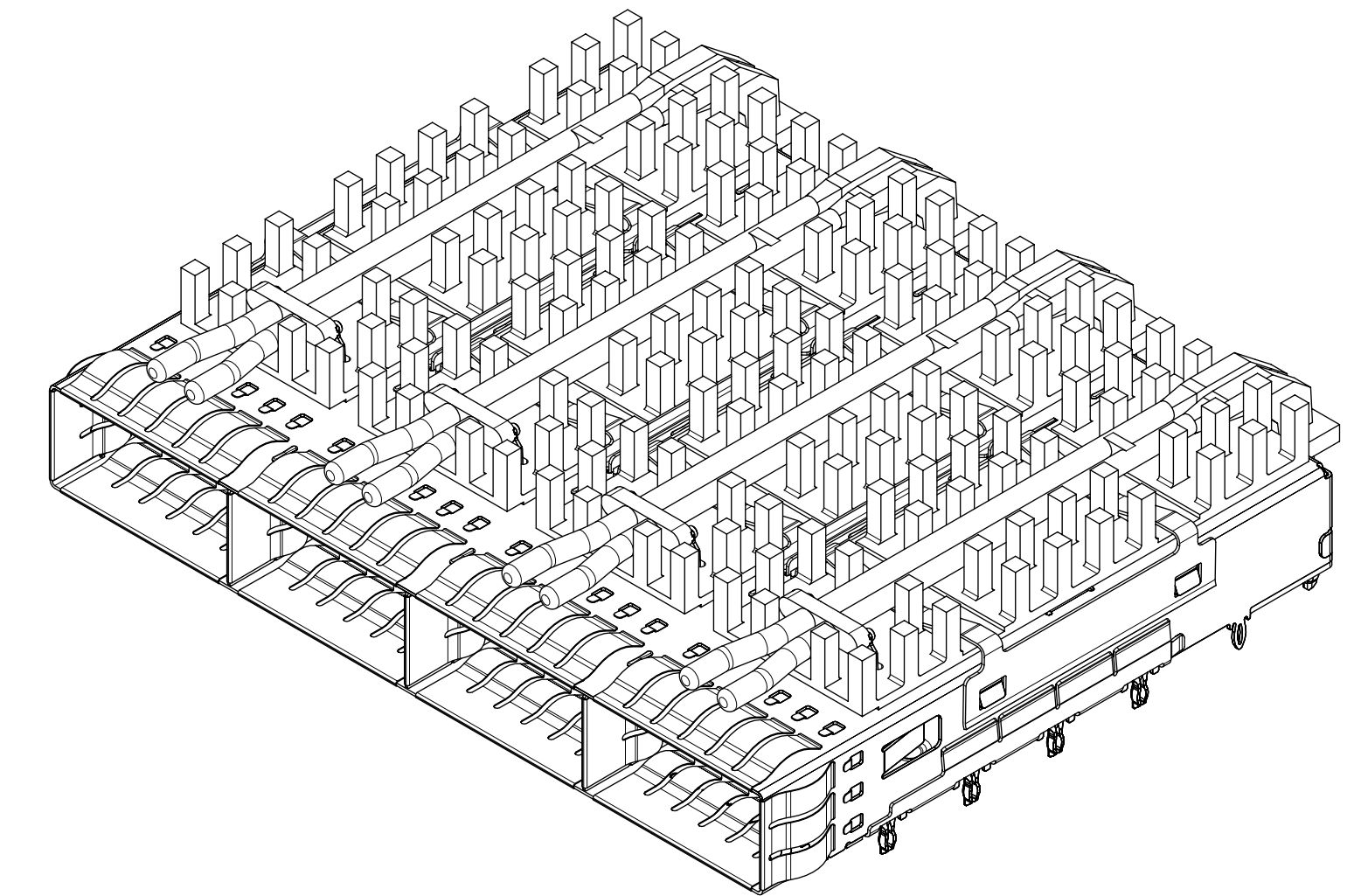
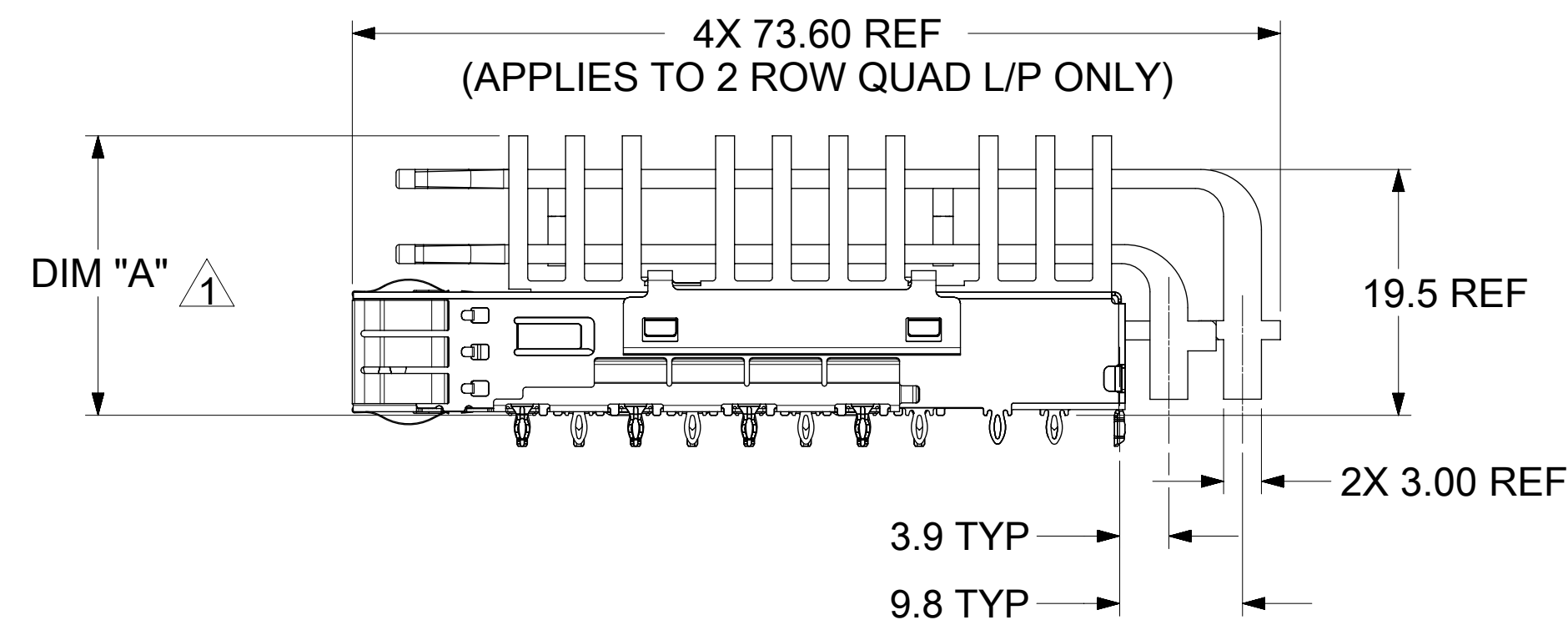
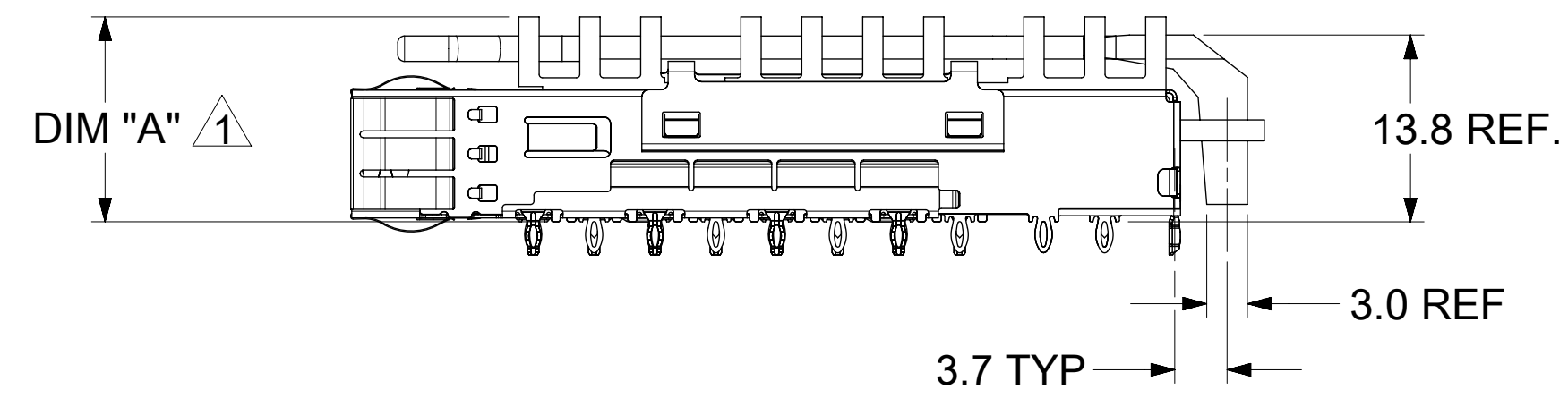
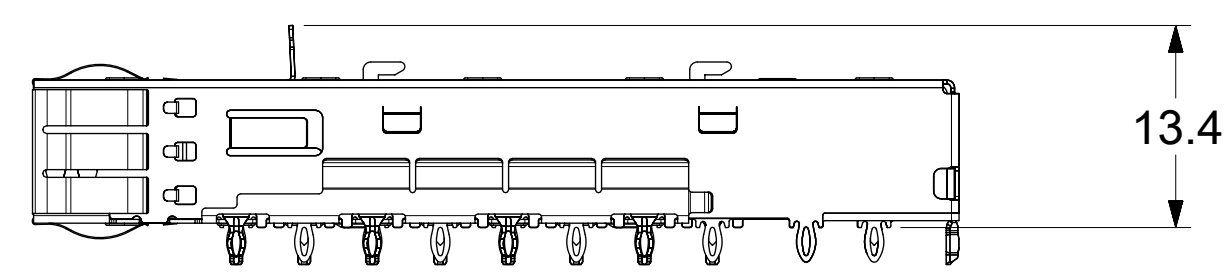
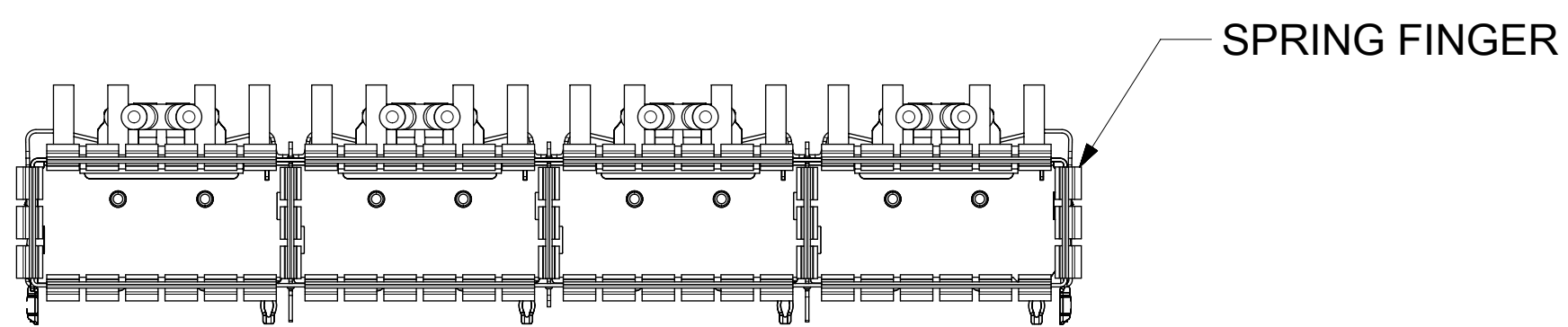
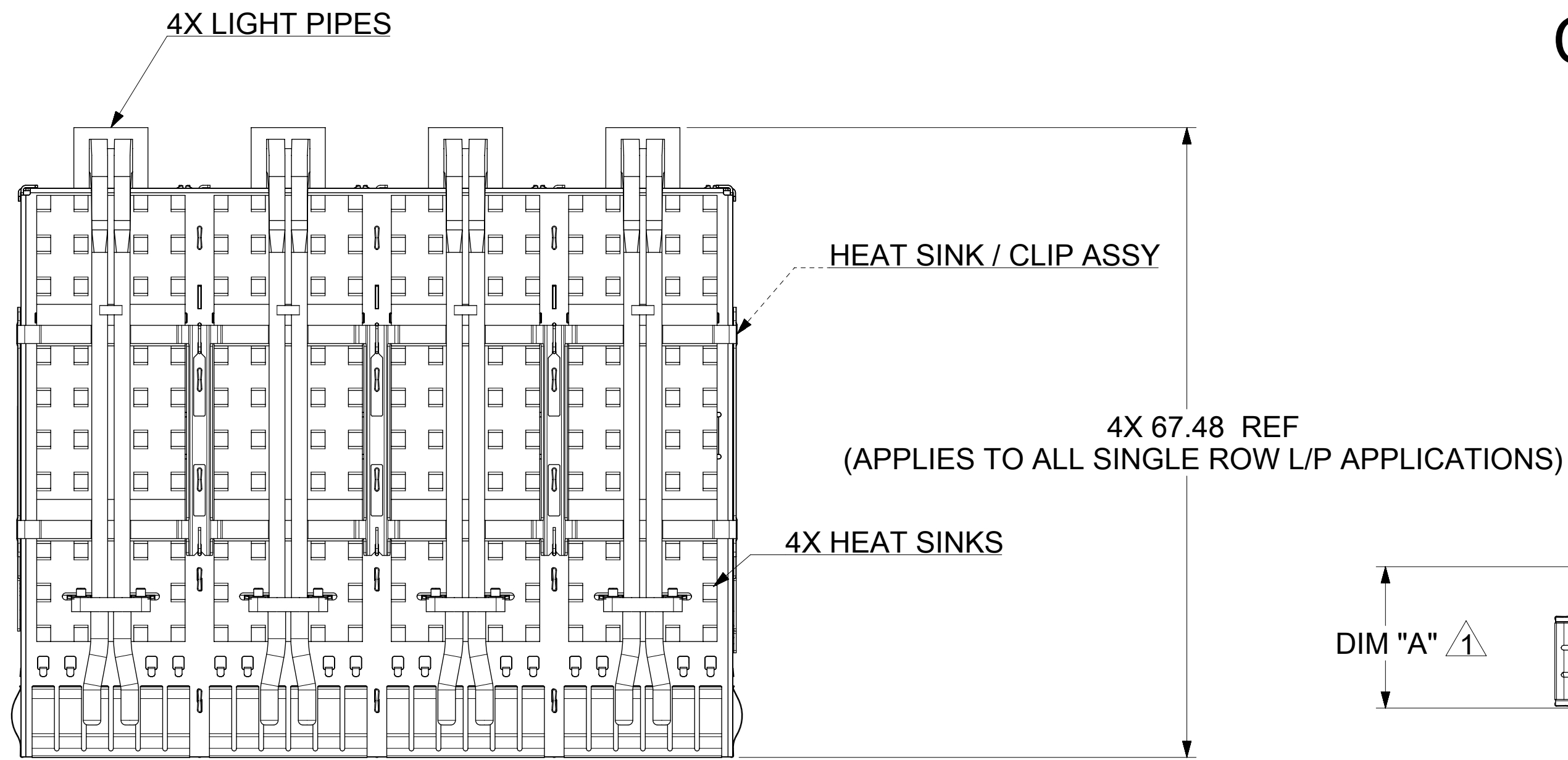

## HEATSINK HEIGHT OPTIONS

OVERALL HEAT SINK HEIGHT	DIM "A"
PCI	13.7 REF
SAN	16.0 REF
NET	23.0 REF

$\triangle$  HEIGHT OF HEAT SINK WITH MODULE INSERTED.  
DIMENSION MAY BE LESS DUE TO MODULE AND HEAT SINK VARIATIONS

## HEATSINK AND LIGHT PIPE COMBINATIONS

HEATSINK USED WITHOUT LIGHTPIPE

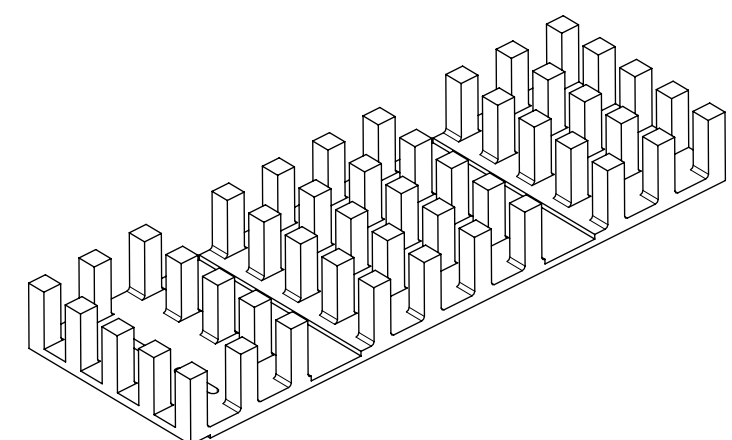

SINGLE / DUAL LIGHT PIPE

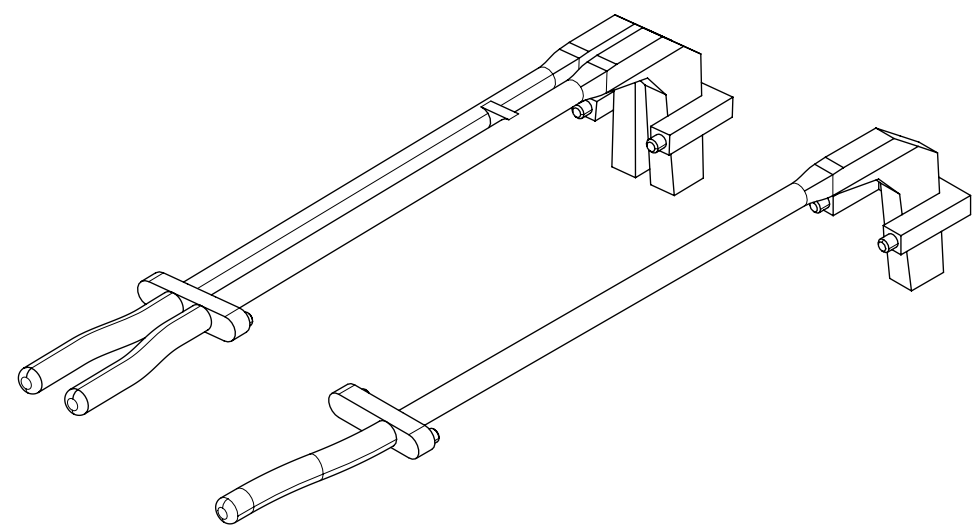

HEATSINK

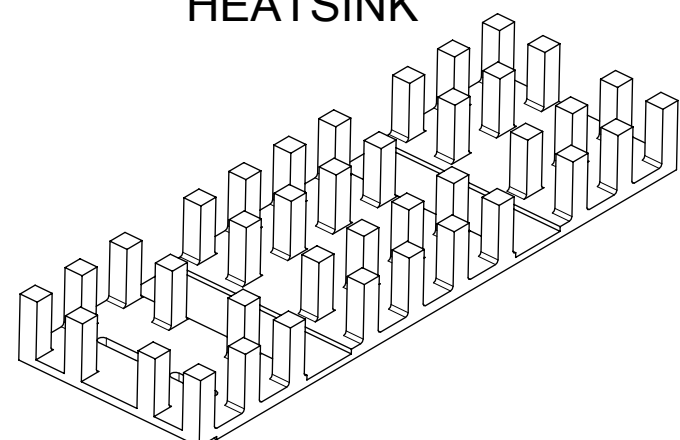

QUAD LIGHT PIPE

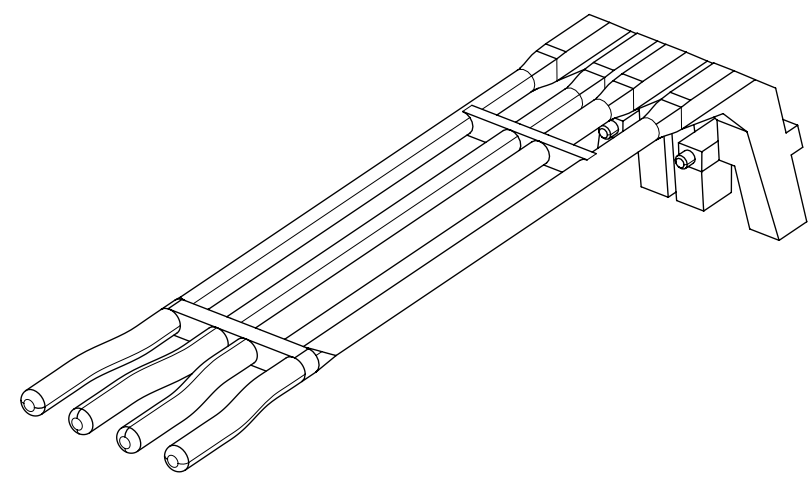

HEATSINK

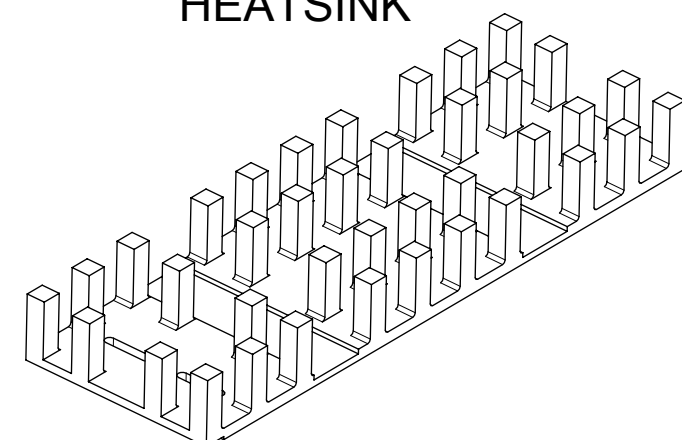

2 ROW QUAD LIGHT PIPE

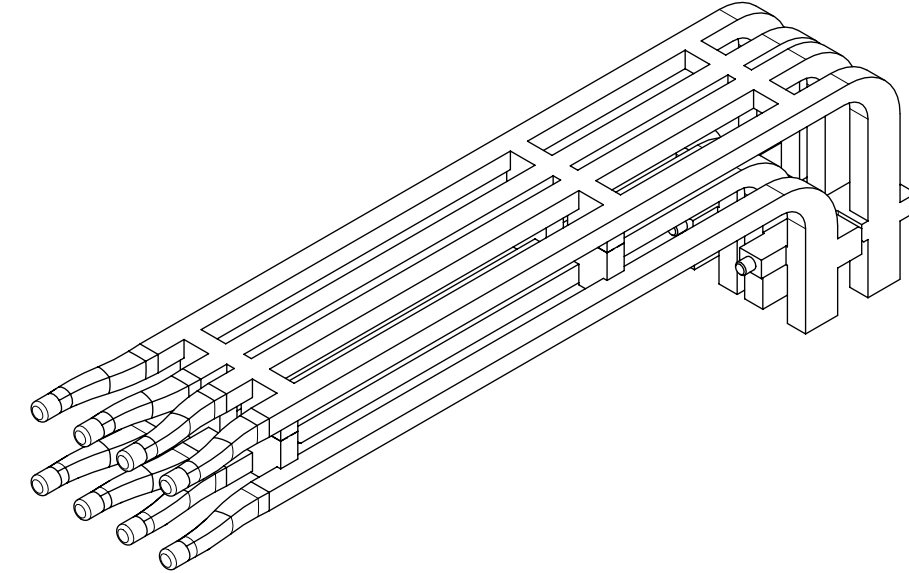

HEATSINK

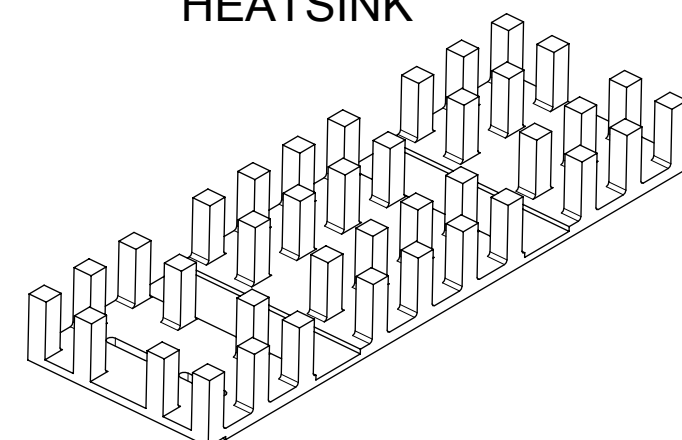

## REAR LEG OPTIONS

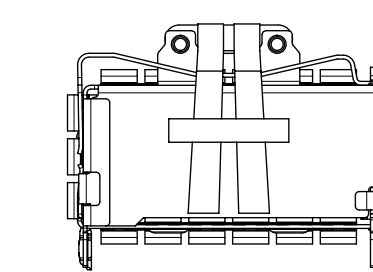

0 REAR LEGS

Partial1  
Scale 2.5:1

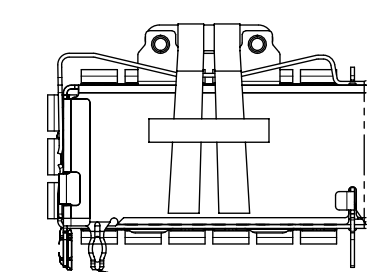

1 REAR LEGS

Partial2  
Scale 2.5:1

THIS DRAWING CONTAINS INFORMATION THAT IS PROPRIETARY TO MOLEX ELECTRONIC TECHNOLOGIES, LLC AND SHOULD NOT BE USED WITHOUT WRITTEN PERMISSION

DIMENSION UNITS	SCALE	CURRENT REV DESC: REACTIVATED PART NUMBER	
mm	2:1		
GENERAL TOLERANCES (UNLESS SPECIFIED)			
ANGULAR TOL $\pm$ 1.0°			
4 PLACES	$\pm$	EC NO: 643481	2020/08/17
3 PLACES	$\pm$	DRWN: AKUMAR19	2020/08/25
2 PLACES	$\pm$ 0.13	CHK'D: GB	2020/08/25
1 PLACE	$\pm$ 0.25	APPR: GB	
0 PLACES	$\pm$	INITIAL REVISION:	
DRAFT WHERE APPLICABLE MUST REMAIN WITHIN DIMENSIONS		DRWN: KNAGANNA	2015/06/03
		APPR: RCHEN08	2016/01/11
THIRD ANGLE PROJECTION		DRAWING	SERIES
		D-SIZE	100017
		MATERIAL NUMBER	CUSTOMER
		SEE TABLE	GENERAL MARKET
		DOCUMENT NUMBER	DOC TYPE DOC PART REVISION
		1000171200	PSD SD L
		SHEET NUMBER	
		2 OF 9	

**molex**

ZQSFP+ 1X4 GANGED CAGE ASSY'S (SPRING FINGER) WITH H/S & L/P OPTIONS

PRODUCT CUSTOMER DRAWING

DOCUMENT NUMBER DOC TYPE DOC PART REVISION

1000171200 PSD SD L

MATERIAL NUMBER CUSTOMER SHEET NUMBER

SEE TABLE GENERAL MARKET 2 OF 9

# PART NUMBER SELECTION

NO HEATSINKS  
WITH LIGHT PIPES  
CLOSED TOP

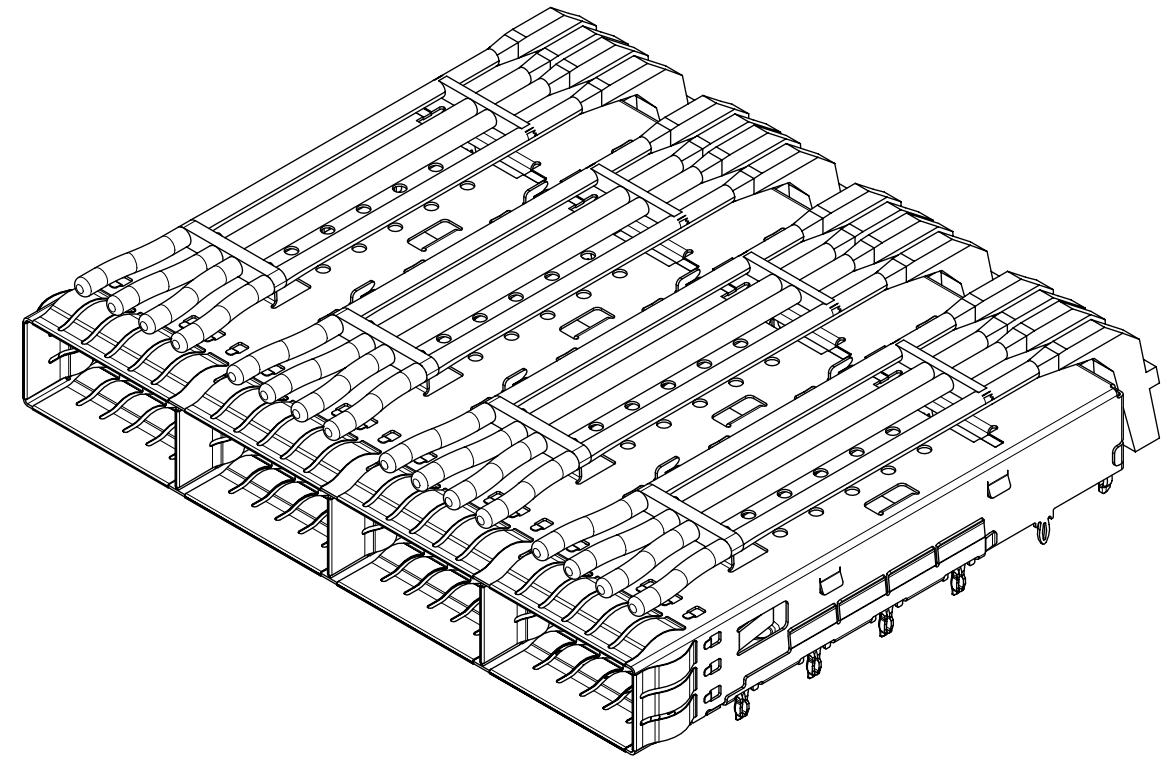

MOLEX P/N	LIGHT PIPES	#OF REAR LEGS PER PORT
1000171231	SINGLE	0
1000171232	SINGLE	1
1000171233	DUAL	0
1000171234	DUAL	1
1000171235	QUAD	0
1000171236	QUAD	1

NO HEATSINKS  
NO LIGHT PIPES  
CLOSED TOP

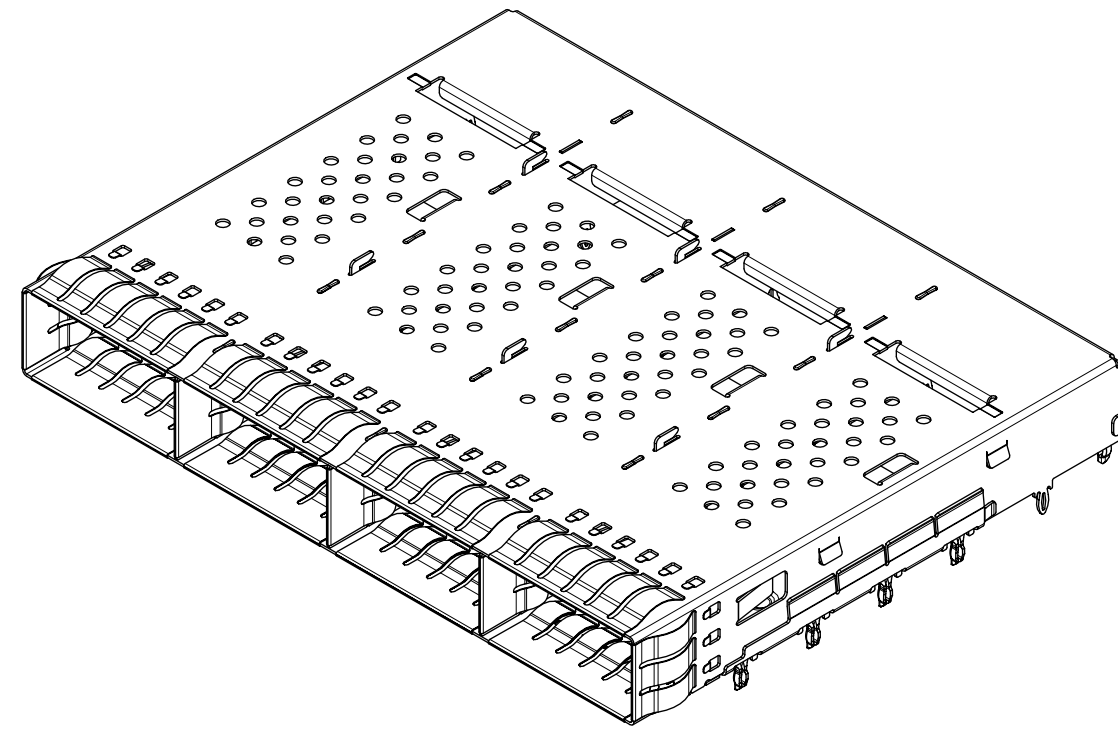

MOLEX P/N W/ SPRING FINGERS	#OF REAR LEGS PER PORT
1000171242	1

NO HEATSINKS  
NO LIGHT PIPES  
OPEN TOP

LIGHT PIPE FEATURE

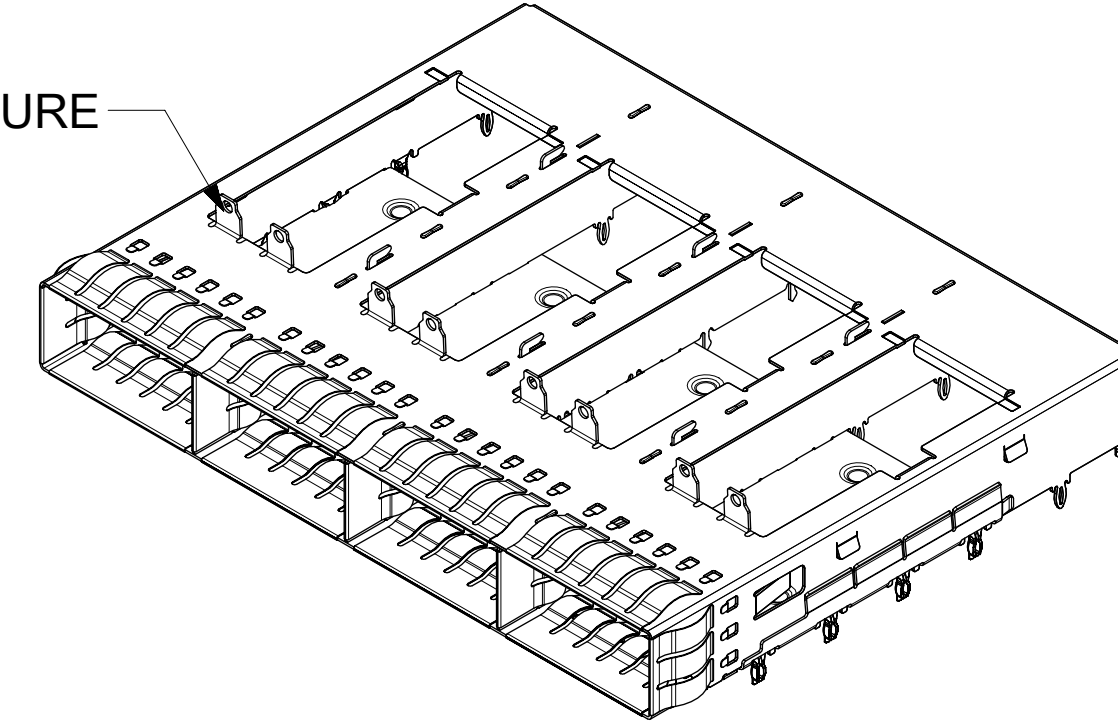

MOLEX P/N W/ SPRING FINGERS	#OF REAR LEGS PER PORT	LIGHT PIPE FEATURE
1000171250	0	YES
1000171252	1	YES
1000171255	1	NO

WITH HEATSINKS  
NO LIGHT PIPES

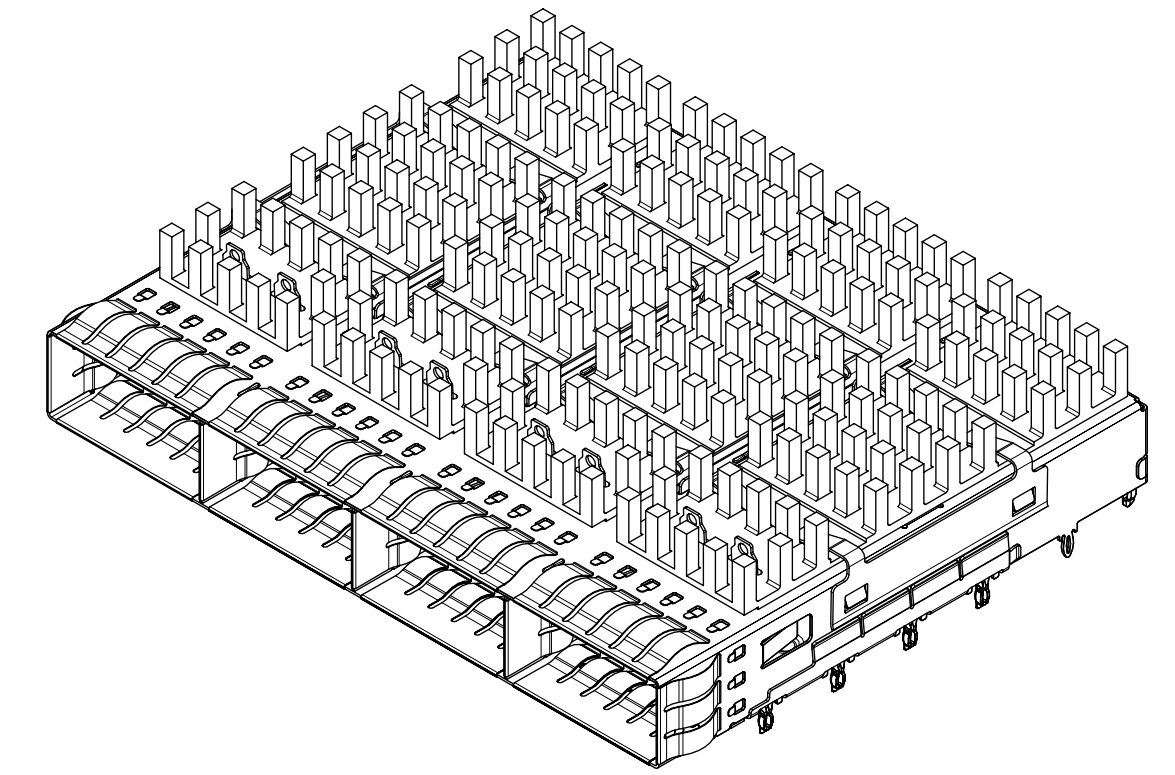

MOLEX P/N	HEATSINKS	#OF REAR LEGS PER PORT
1000171340	PCI	0
1000171341	SAN	0
1000171342	NET	0
1000171343	PCI	1
1000171344	SAN	1
1000171345	NET	1

## WITH HEATSINKS AND LIGHT PIPES

MOLEX P/N	LIGHTPIPES	HEATSINKS	#OF REAR LEGS PER PORT
1000171440	SINGLE	PCI	0
1000171441	SINGLE	SAN	0
1000171442	SINGLE	NET	0
1000171443	DUAL	PCI	0
1000171444	DUAL	SAN	0
1000171445	DUAL	NET	0
1000171446	QUAD	PCI	0
1000171447	QUAD	SAN	0
1000171540	SINGLE	PCI	1
1000171541	SINGLE	SAN	1
1000171542	SINGLE	NET	1
1000171544	DUAL	SAN	1
1000171545	DUAL	NET	1
1000171546	QUAD	PCI	1
1000171547	QUAD	SAN	1
1000171548	QUAD	NET	1
1000171648	2 ROW QUAD	NET	1
1000171649	2 ROW QUAD	CUSTOM (A=19.0 REF)	1

SINGLE LIGHT PIPE

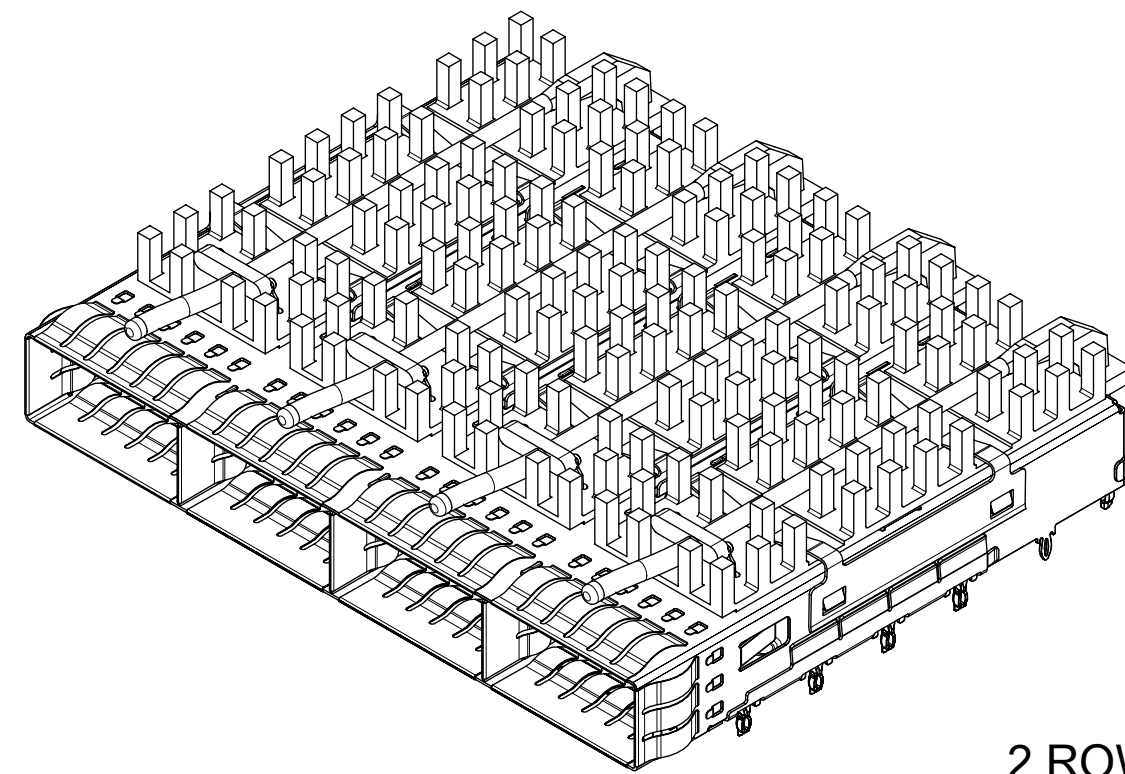

DUAL LIGHT PIPE

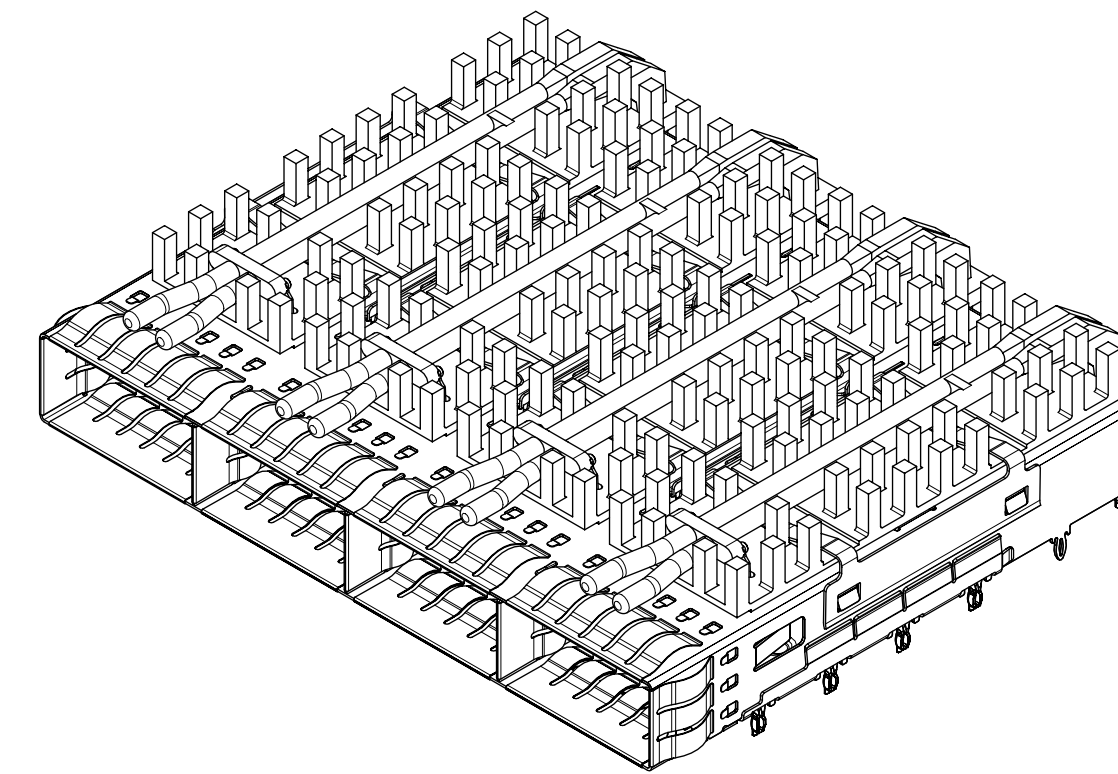

QUAD LIGHT PIPE

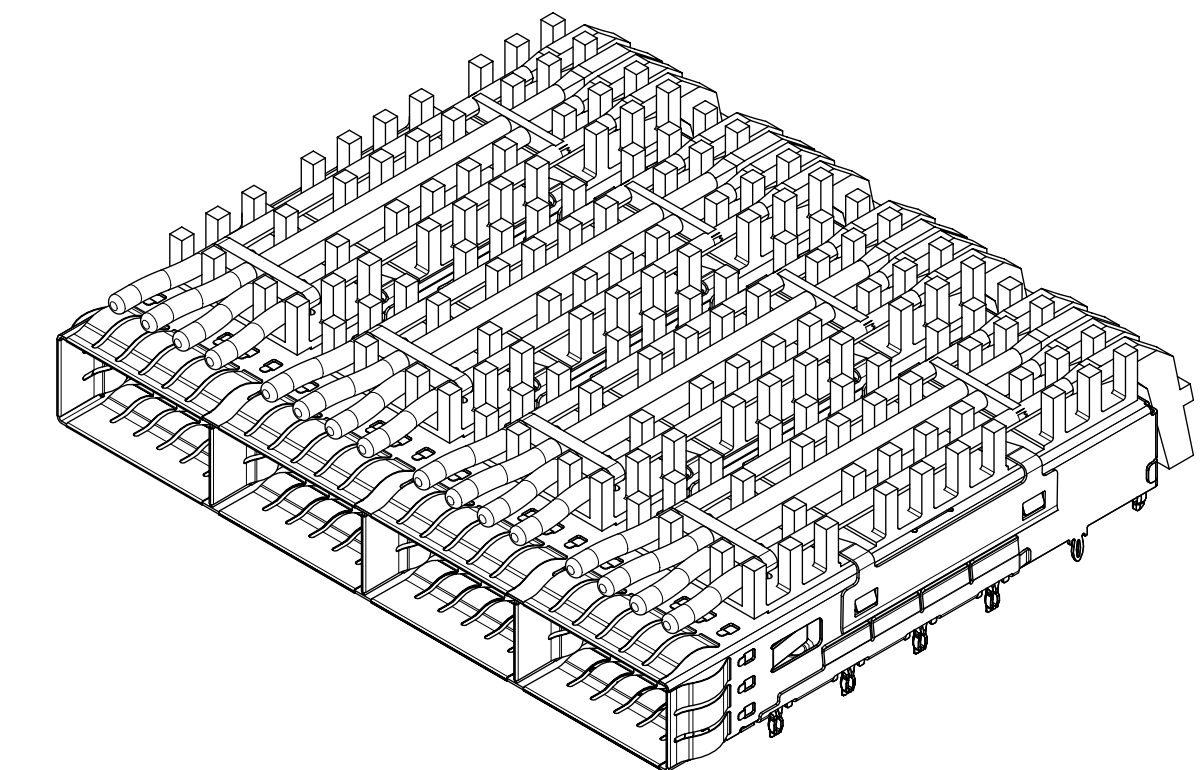

2 ROW QUAD LIGHT PIPE

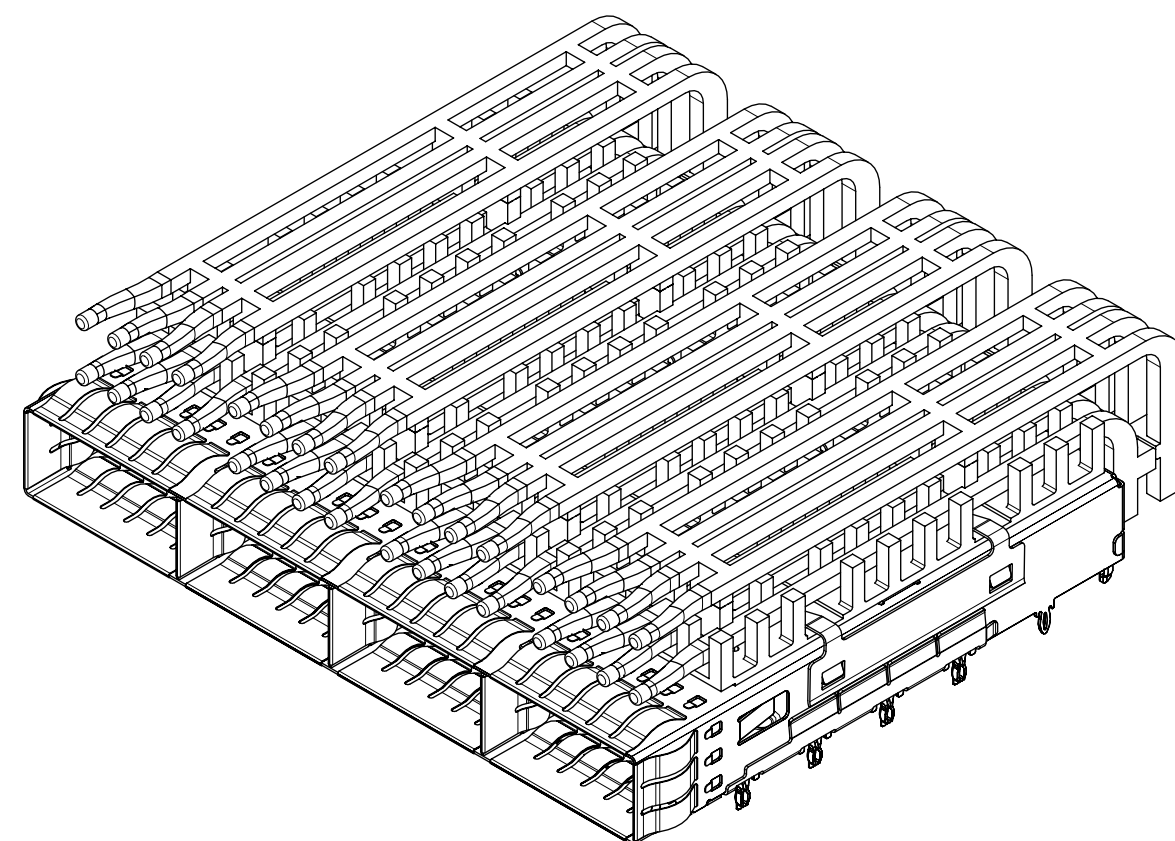

THIS DRAWING CONTAINS INFORMATION THAT IS PROPRIETARY TO MOLEX ELECTRONIC TECHNOLOGIES, LLC AND SHOULD NOT BE USED WITHOUT WRITTEN PERMISSION

DIMENSION UNITS <b>mm</b>	SCALE <b>1.5:1</b>	CURRENT REV DESC: REACTIVATED PART NUMBER			
GENERAL TOLERANCES (UNLESS SPECIFIED)		EC NO: 643481			
ANGULAR TOL	± 1.0°	DRWN: AKUMAR19 2020/08/17		PRODUCT CUSTOMER DRAWING	
4 PLACES	±	CHK'D: GB 2020/08/25		DOCUMENT NUMBER	
3 PLACES	±	APPR: GB 2020/08/25		1000171200	
2 PLACES	± 0.13	INITIAL REVISION:		DOC TYPE	DOC PART
1 PLACE	± 0.25	DRWN: KNAGANNA 2015/06/03		PSD	SD
0 PLACES	±	APPR: RCHEN08 2016/01/11		REVISION	L
DRAFT WHERE APPLICABLE MUST REMAIN WITHIN DIMENSIONS		THIRD ANGLE PROJECTION	DRAWING	SERIES	MATERIAL NUMBER
			<b>D-SIZE</b>	100017	SEE TABLE
			CUSTOMER	GENERAL MARKET	SHEET NUMBER
					3 OF 9

# PCB LAYOUT FOR SINGLE SIDED MOUNTING

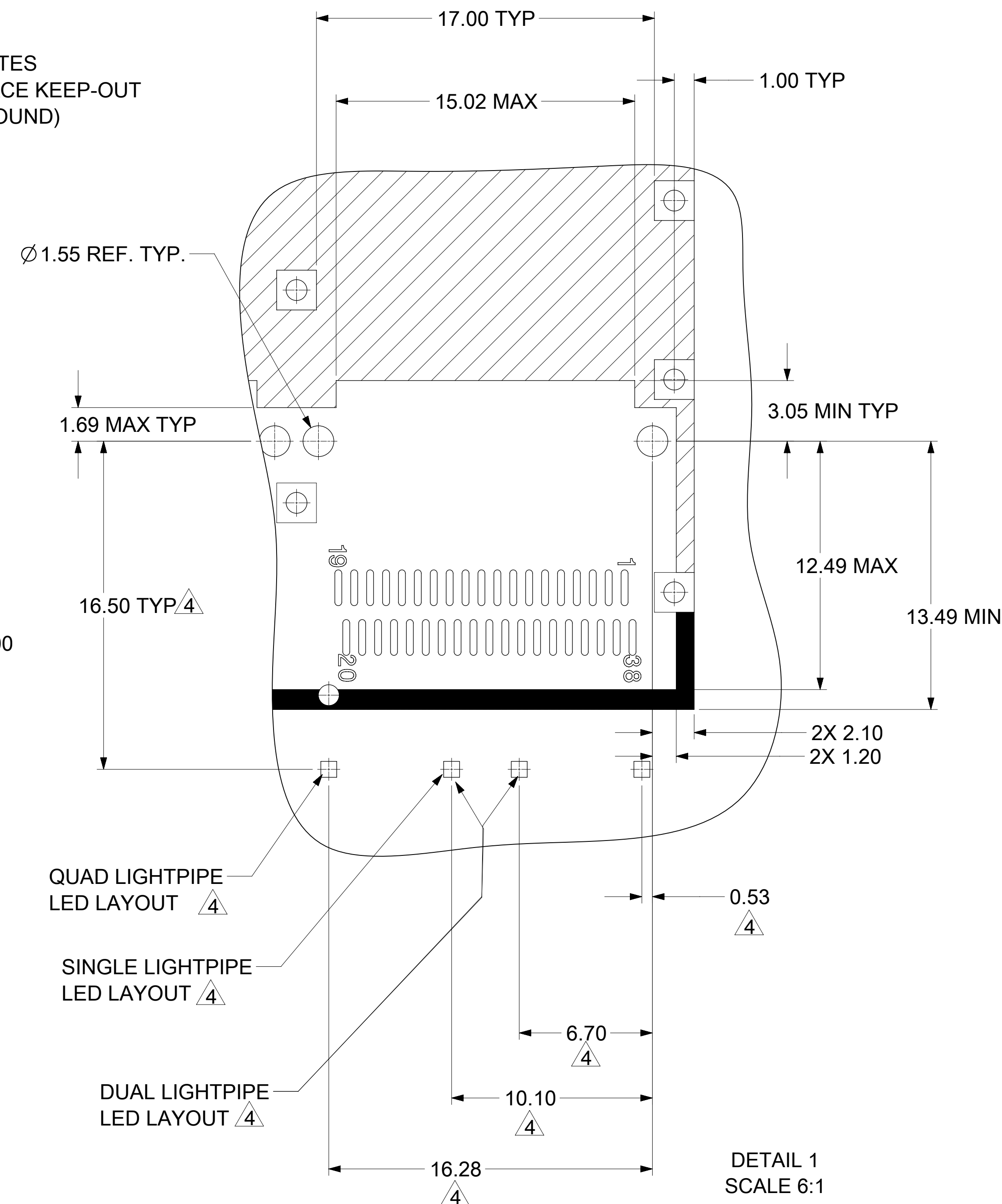
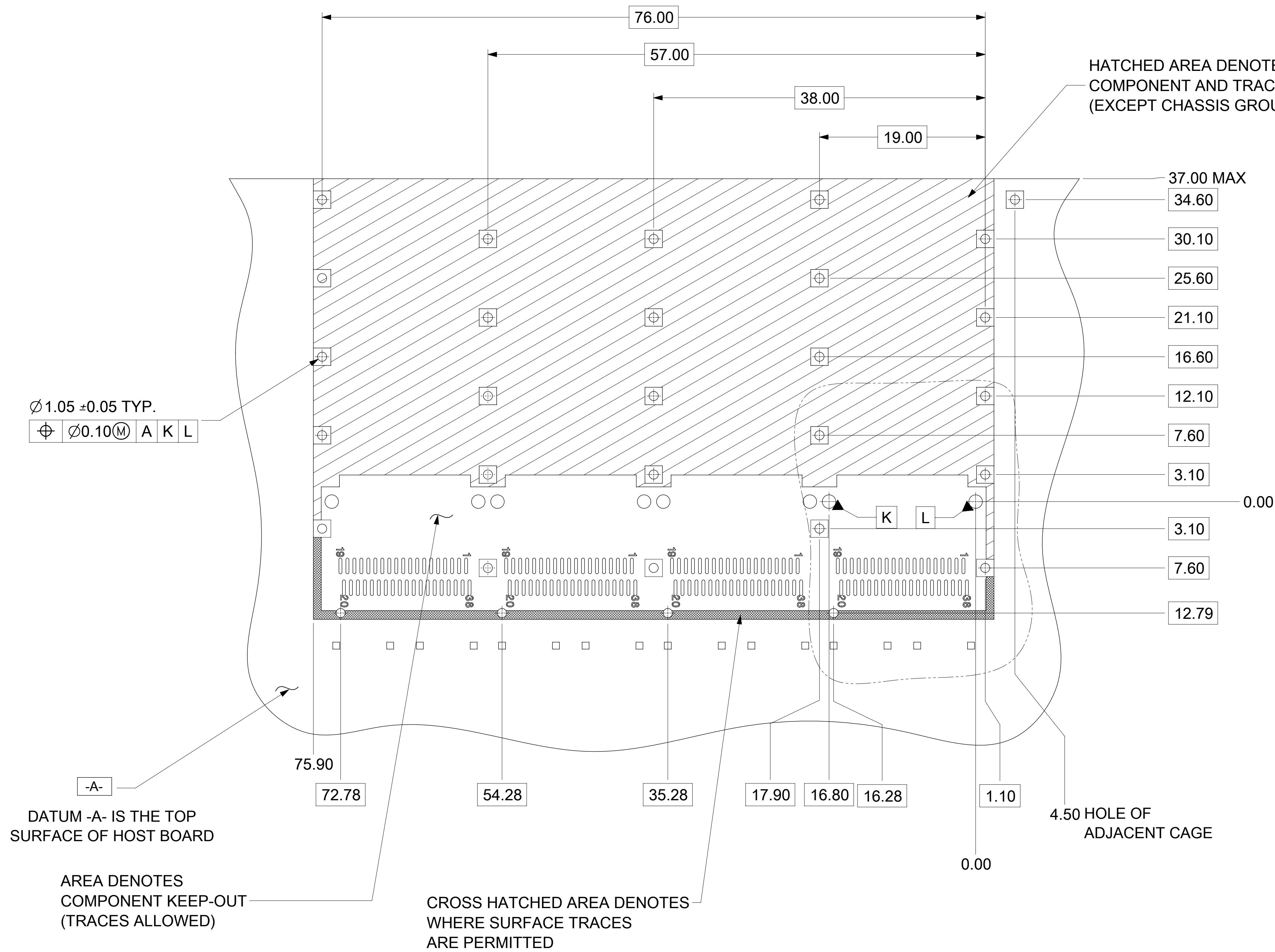

- NOTES:
1. PADS AND VIAS GO TO CHASSIS GROUND. (RECOMMENDED PADS TO BE 2.00mm SQUARE.)
  2. RECOMMENDED THRU HOLE PLATING INCLUDES HASL, OSP, OR IMMERSION (GOLD, SILVER, OR TIN).
  3. CONNECTOR PAD LAYOUT PER SFF-8663 WILL ACCOMODATE MOLEX CONNECTOR SERIES 170432.
  4. NOTED DIMENSIONS ONLY APPLY TO CAGE ASSEMBLIES WITH LIGHT PIPES.

THIS DRAWING CONTAINS INFORMATION THAT IS PROPRIETARY TO MOLEX ELECTRONIC TECHNOLOGIES, LLC AND SHOULD NOT BE USED WITHOUT WRITTEN PERMISSION									
DIMENSION UNITS		SCALE		CURRENT REV DESC: REACTIVATED PART NUMBER					
mm		3.5:1							
GENERAL TOLERANCES (UNLESS SPECIFIED)									
ANGULAR TOL ± 1.0°									
4 PLACES ±		EC NO: 643481		DRWN: AKUMAR19		2020/08/17			
3 PLACES ±		CHK'D: GB		APPR: GB		2020/08/25			
2 PLACES ± 0.13		INITIAL REVISION:		DRWN: KNAGANNA		2015/06/03			
1 PLACE ± 0.25		DRWN: RCHEN08		APPR: RCHEN08		2016/01/11			
0 PLACES ±		DRAFT WHERE APPLICABLE MUST REMAIN WITHIN DIMENSIONS		THIRD ANGLE PROJECTION		DRAWING		SERIES	
				D-SIZE		100017		MATERIAL NUMBER	
				SEE TABLE		GENERAL MARKET		CUSTOMER	
								SHEET NUMBER	
								4 OF 9	



# LED PLACEMENT FOR 2 ROW QUAD LIGHT PIPE

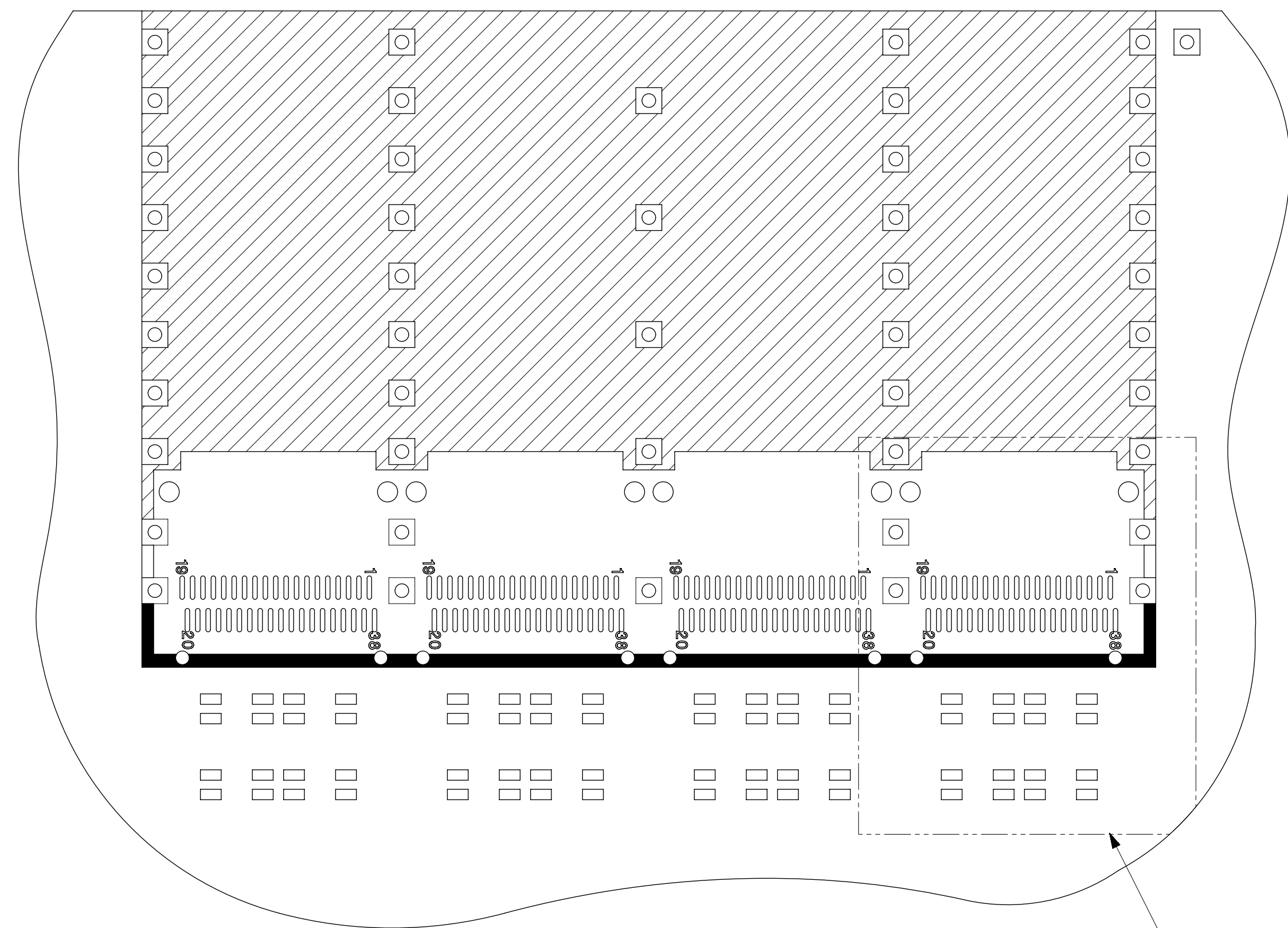

SEE Detail 1

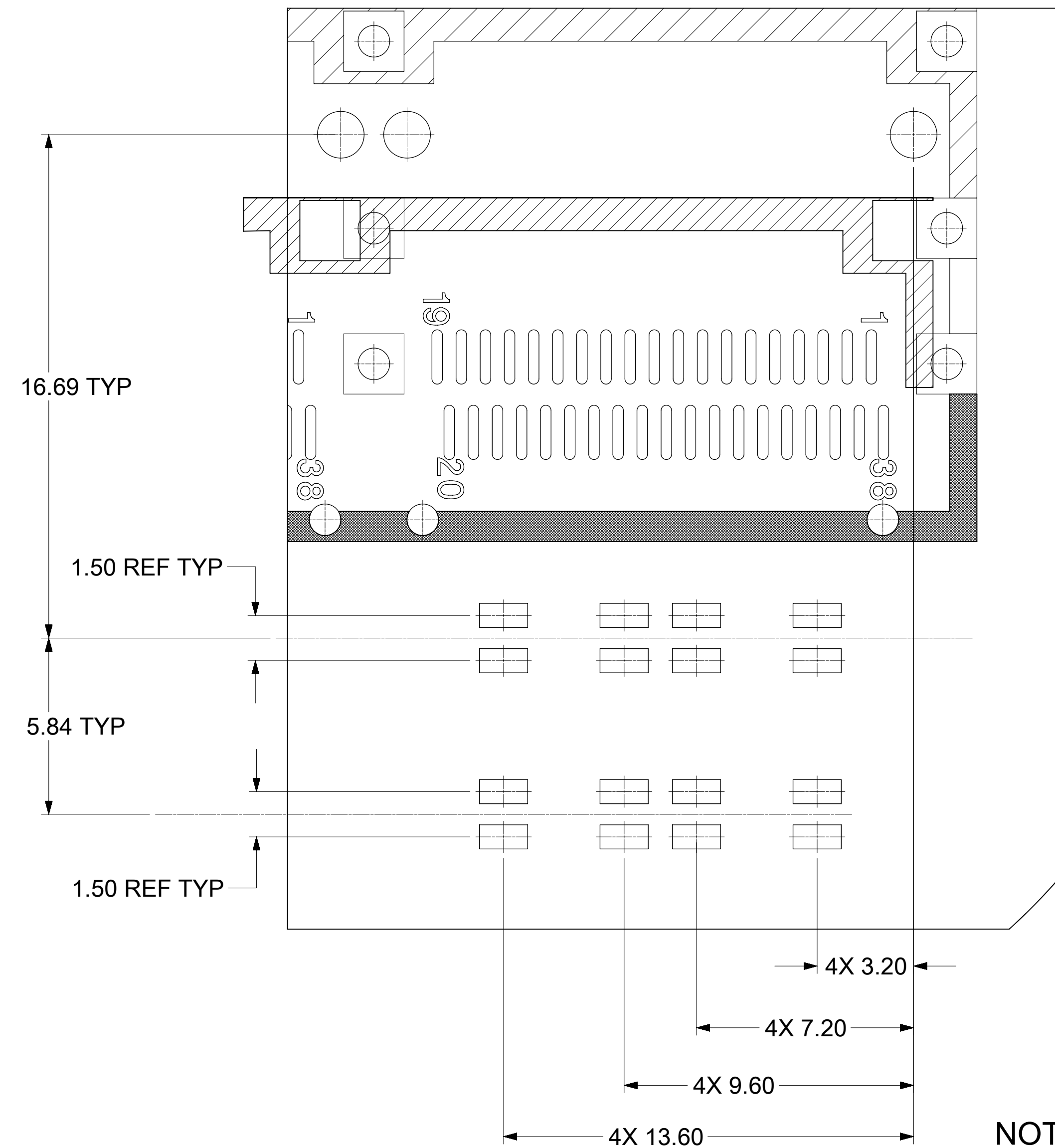

Detail 1  
Scale 8:1

NOTE:  
SEE SHEET 4 FOR HOST  
CONNECTOR DETAIL

THIS DRAWING CONTAINS INFORMATION THAT IS PROPRIETARY TO MOLEX ELECTRONIC TECHNOLOGIES, LLC AND SHOULD NOT BE USED WITHOUT WRITTEN PERMISSION

DIMENSION UNITS <b>mm</b>	SCALE <b>3:1</b>	CURRENT REV DESC: REACTIVATED PART NUMBER		<b>molex</b>			
GENERAL TOLERANCES (UNLESS SPECIFIED)		EC NO: 643481					
ANGULAR TOL	± 1.0°	DRWN: AKUMAR19 2020/08/17		PRODUCT CUSTOMER DRAWING			
4 PLACES	±	CHK'D: GB 2020/08/25		DOCUMENT NUMBER			
3 PLACES	±	APPR: GB 2020/08/25		1000171200			
2 PLACES	± 0.13	INITIAL REVISION:		DOC TYPE			
1 PLACE	± 0.25	DRWN: KNAGANNA 2015/06/03		PSD			
0 PLACES	±	APPR: RCHEN08 2016/01/11		SD			
DRAFT WHERE APPLICABLE MUST REMAIN WITHIN DIMENSIONS		THIRD ANGLE PROJECTION		SERIES		REVISION	
		D-SIZE		100017		L	
		DRAWING		MATERIAL NUMBER		CUSTOMER	
		SEE TABLE		GENERAL MARKET		SHEET NUMBER	
						6 OF 9	

# BEZEL AND BOARD POSITION DIMENSIONS FOR BELLY TO BELLY MOUNTING

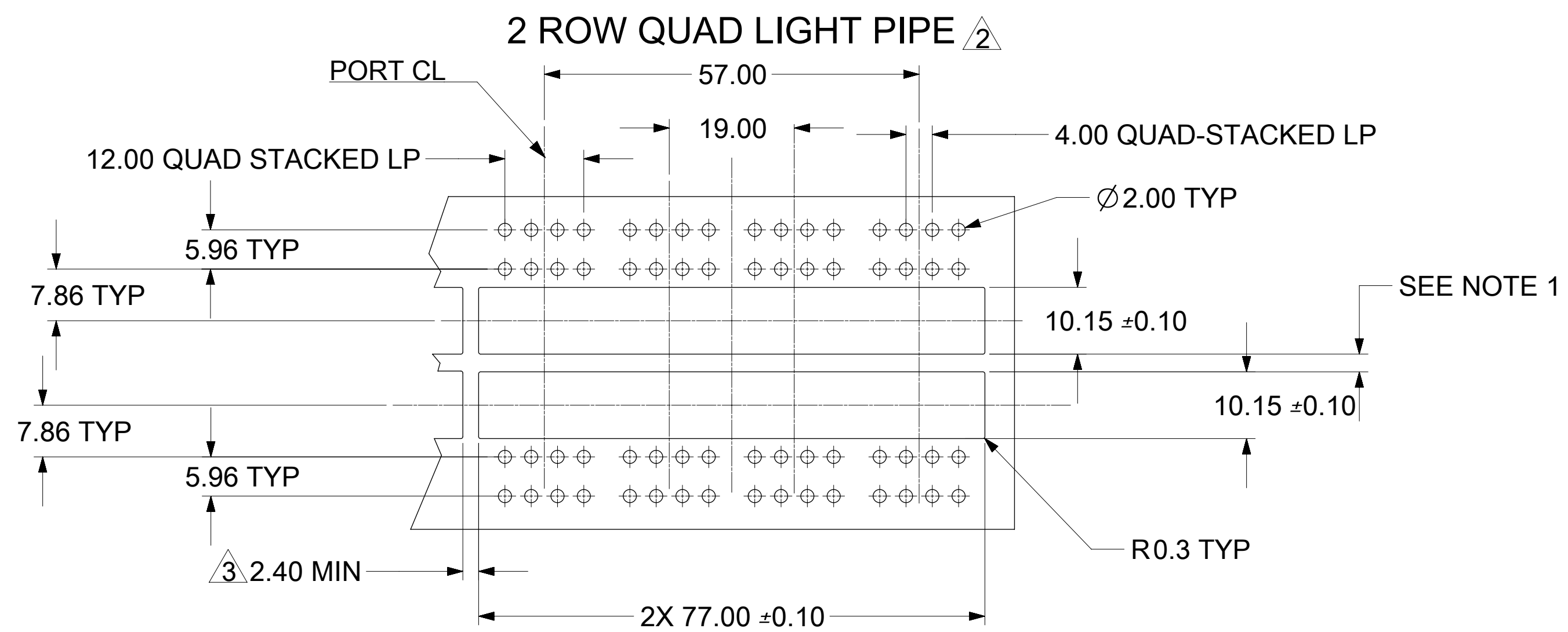
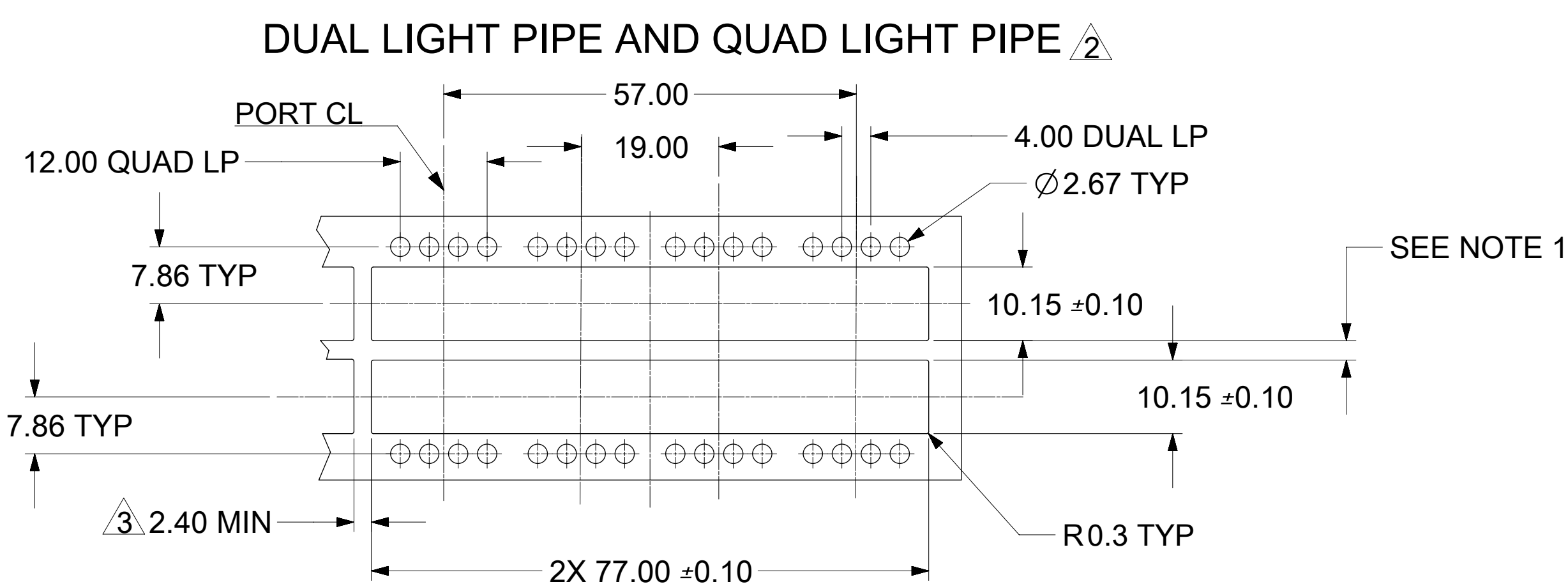
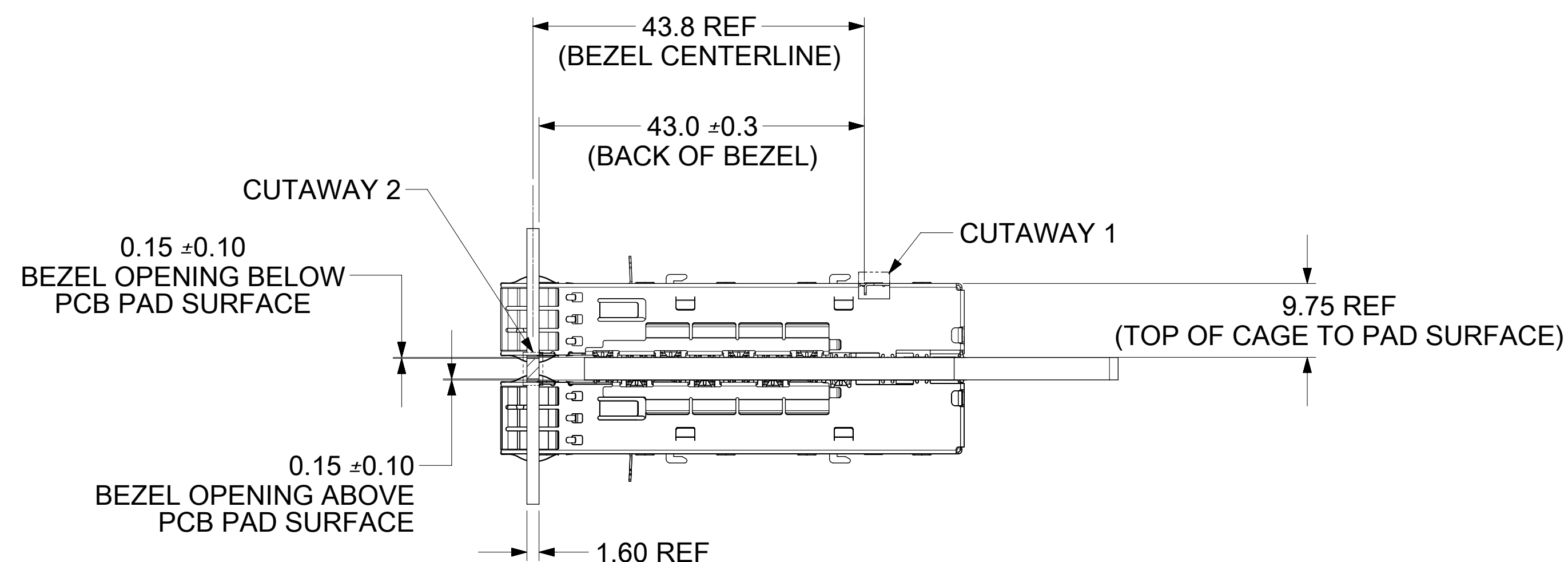
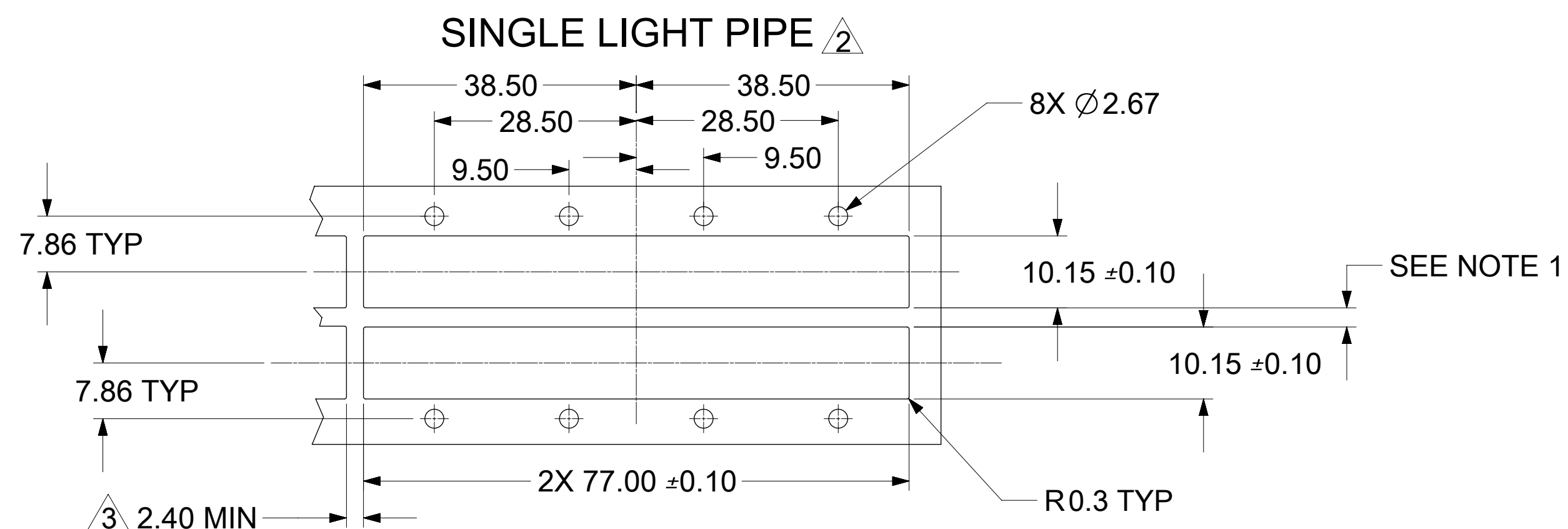

NOTE:  
 1. PCB THICKNESS VARIATION MUST BE CONSIDERED WHEN DETERMINING BEZEL OPENING LOCATION.  
 2. NOTED DIMENSIONS ONLY APPLY TO CAGE ASSEMBLIES WITH LIGHT PIPES.  
 3. THIS DIMENSION IS FOR REFERENCE ONLY. USER CAN MODIFY IT DEPENDS ON APPLICATION. (THIS DIMENSION VARIES BASED ON DISTANCE OF " HOLE OF ADJACENT CAGE" ON PCB LAYOUT.)

THIS DRAWING CONTAINS INFORMATION THAT IS PROPRIETARY TO MOLEX ELECTRONIC TECHNOLOGIES, LLC AND SHOULD NOT BE USED WITHOUT WRITTEN PERMISSION											
DIMENSION UNITS	SCALE	CURRENT REV DESC: REACTIVATED PART NUMBER									
mm	2.5:1	<p>ZQSFP+ 1X4 GANGED CAGE ASSY'S (SPRING FINGER) WITH H/S &amp; L/P OPTIONS</p> <p>PRODUCT CUSTOMER DRAWING</p>									
GENERAL TOLERANCES (UNLESS SPECIFIED)											
ANGULAR TOL	± 1.0°										
4 PLACES	±										
3 PLACES	±										
2 PLACES	± 0.13	EC NO: 643481	2020/08/17	2020/08/25	2020/08/25	DOCUMENT NUMBER			DOC TYPE	DOC PART	REVISION
1 PLACE	± 0.25	DRWN: AKUMAR19	2020/08/17	2020/08/25	2020/08/25	1000171200			PSD	SD	L
0 PLACES	±	CHK'D: GB	2020/08/17	2020/08/25	2020/08/25	1000171200			PSD	SD	L
DRAFT WHERE APPLICABLE MUST REMAIN WITHIN DIMENSIONS		APPR: GB	2020/08/17	2020/08/25	2020/08/25	1000171200			PSD	SD	L
THIRD ANGLE PROJECTION		INITIAL REVISION:	2015/06/03	2016/01/11	MATERIAL NUMBER			CUSTOMER	SHEET NUMBER		
D-DRAWING		DRWN: KNAGANNA	2015/06/03	2016/01/11	1000171200			GENERAL MARKET	7 OF 9		
D-DRAWING		APPR: RCHEN08	2015/06/03	2016/01/11	1000171200			GENERAL MARKET	7 OF 9		

# BEZEL AND BOARD POSITION DIMENSIONS FOR SINGLE SIDE MOUNTING

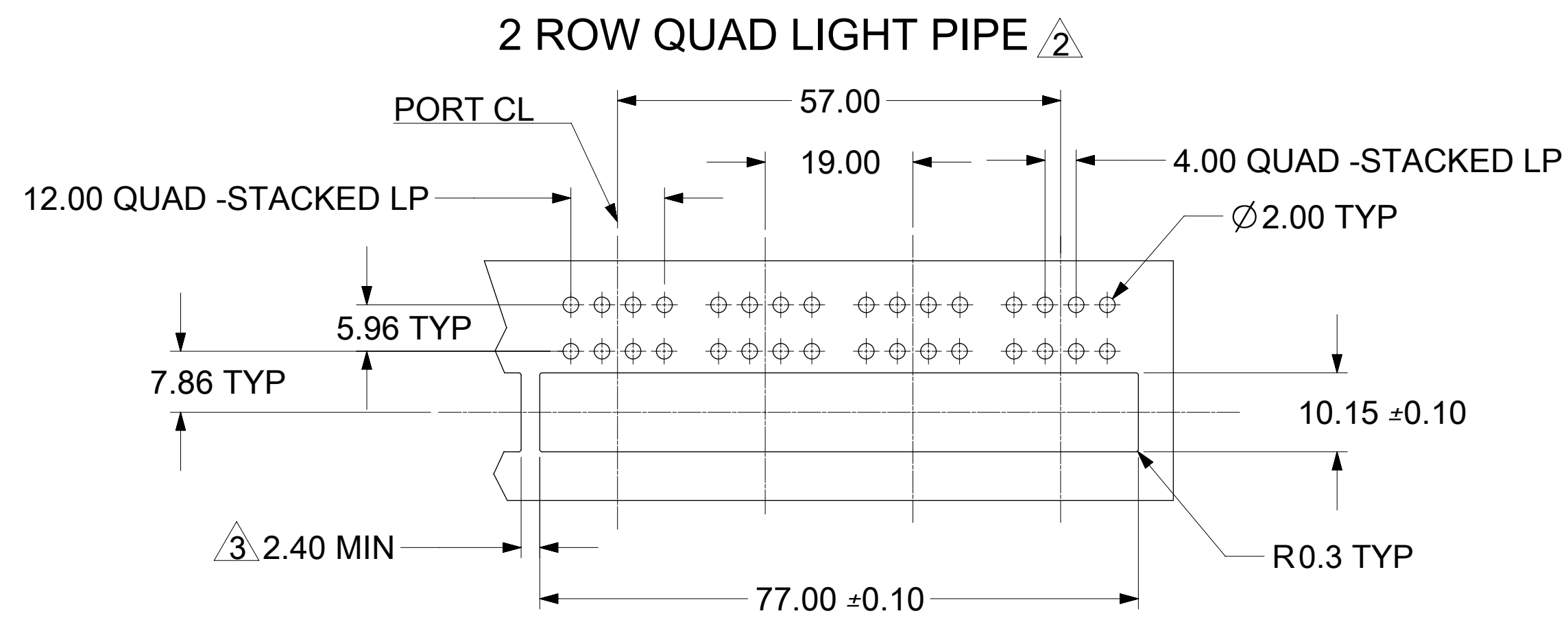
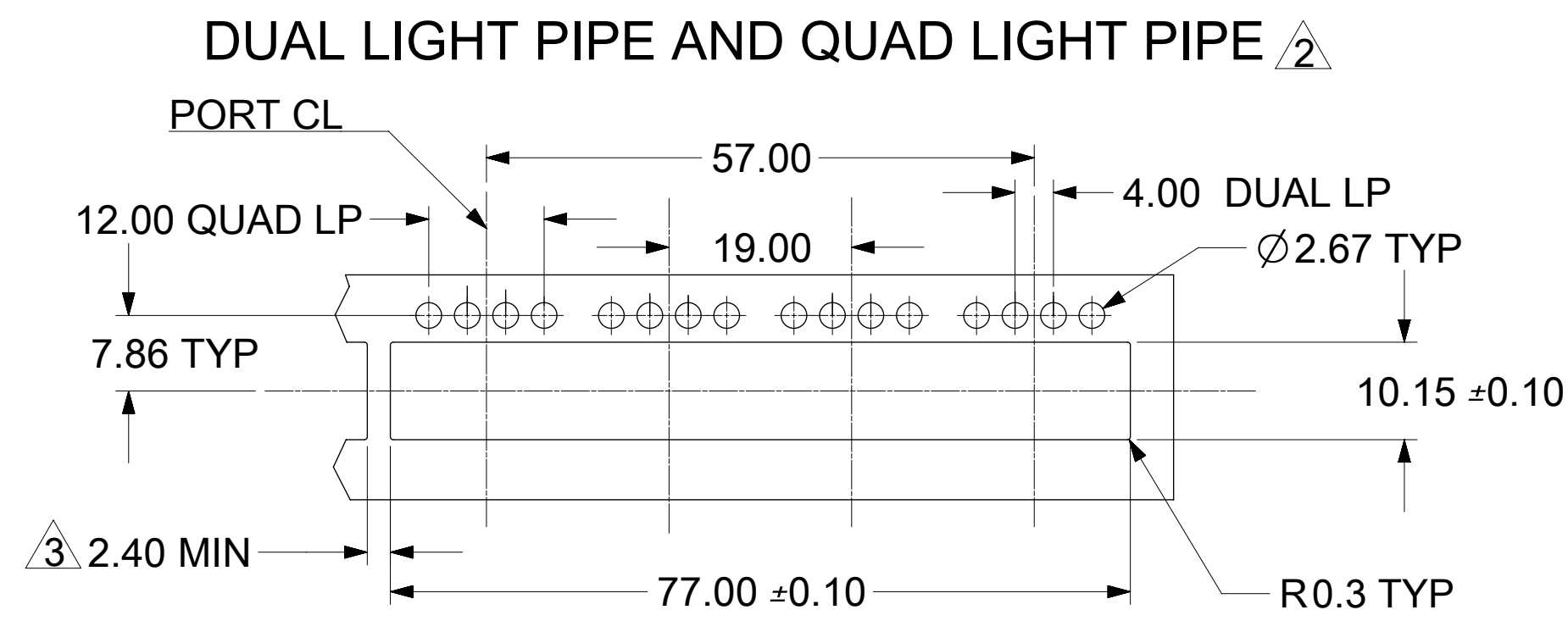
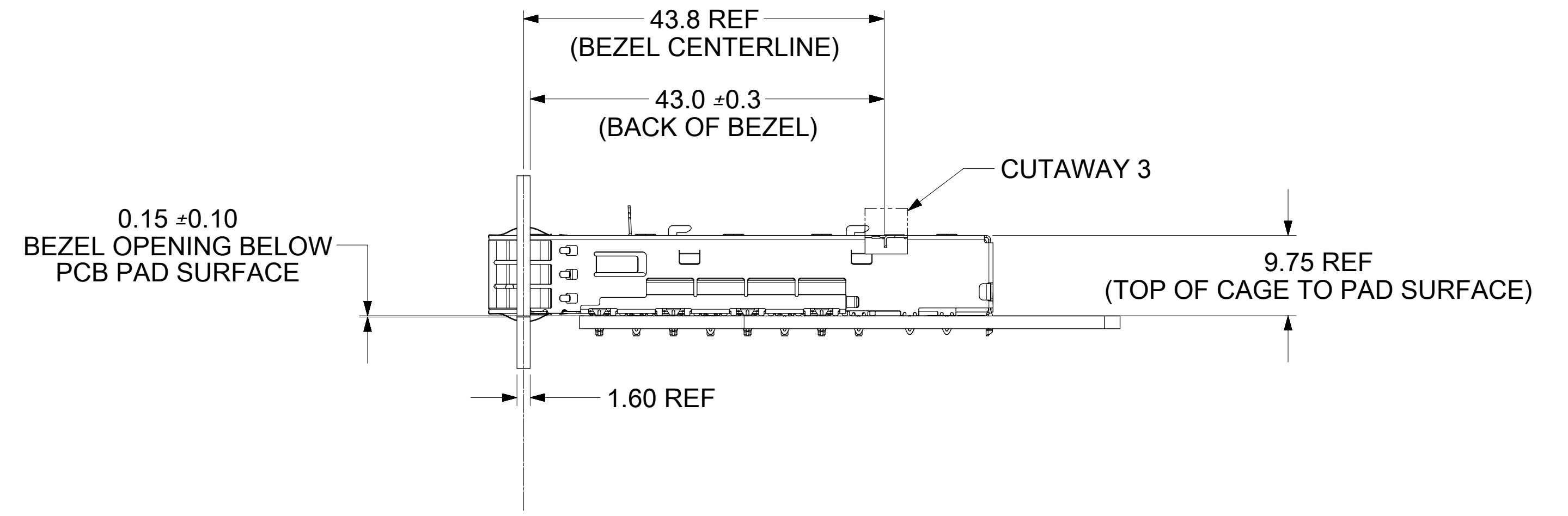
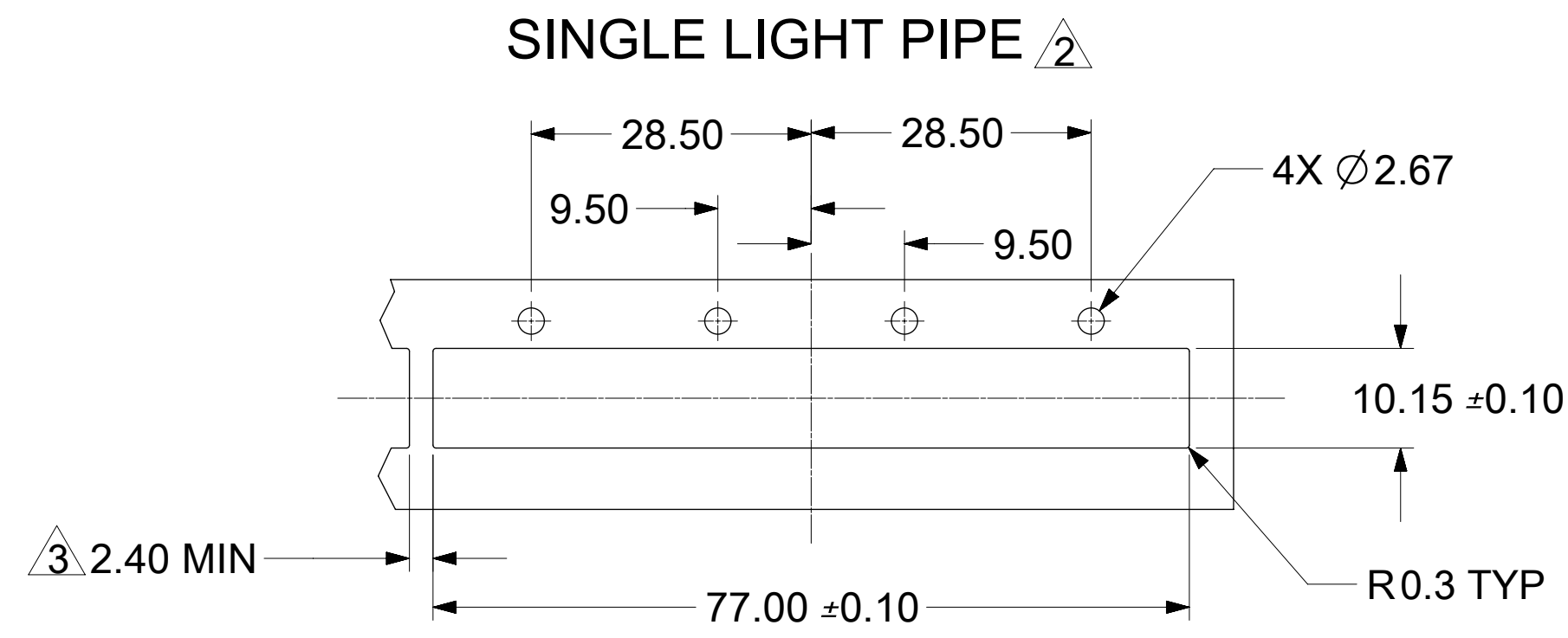

**NOTE:**  
 1. PCB THICKNESS VARIATION MUST BE CONSIDERED WHEN DETERMINING BEZEL OPENING LOCATION.  
<sup>2</sup> NOTED DIMENSIONS ONLY APPLY TO CAGE ASSEMBLIES WITH LIGHT PIPES.  
<sup>3</sup> THIS DIMENSION IS FOR REFERENCE ONLY. USER CAN MODIFY IT DEPENDS ON APPLICATION. (THIS DIMENSION VARIES BASED ON DISTANCE OF " HOLE OF ADIACENT CAGE" ON PCB LAYOUT.)

THIS DRAWING CONTAINS INFORMATION THAT IS PROPRIETARY TO MOLEX ELECTRONIC TECHNOLOGIES, LLC AND SHOULD NOT BE USED WITHOUT WRITTEN PERMISSION											
DIMENSION UNITS	SCALE	CURRENT REV DESC: REACTIVATED PART NUMBER									
mm	1:1	<div style="text-align: center;"><b>molex</b></div> ZQSFP+ 1X4 GANGED CAGE ASSY'S (SPRING FINGER) WITH H/S & L/P OPTIONS PRODUCT CUSTOMER DRAWING									
GENERAL TOLERANCES (UNLESS SPECIFIED)											
ANGULAR TOL	± 1.0°										
4 PLACES	±										
3 PLACES	±										
2 PLACES	± 0.13										
1 PLACE	± 0.25	EC NO: 643481	2020/08/17	DRWN: AKUMAR19				2020/08/25			
0 PLACES	±	CHK'D: GB	2020/08/25	APPR: GB				2020/08/25			
DRAFT WHERE APPLICABLE MUST REMAIN WITHIN DIMENSIONS		THIRD ANGLE PROJECTION	DRAWING	SERIES	MATERIAL NUMBER	CUSTOMER	SHEET NUMBER				
			D-SIZE	100017	SEE TABLE	GENERAL MARKET	8 OF 9				
							INITIAL REVISION:	DOCUMENT NUMBER	DOC TYPE	DOC PART	REVISION
							DRWN: KNAGANNA	1000171200	PSD	SD	L
							APPR: RCHEN08				
							2015/06/03				
							2016/01/11				

DOCUMENT STATUS	P1	RELEASE DATE	2020/08/25	04:10:24
-----------------	----	--------------	------------	----------

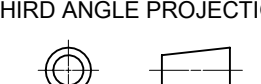

REV	DATE	DESCRIPTION
A	03/29/2013	RELEASE
B	06/26/2013	ADDED DIM 12.77 AT G-9 ON SHEET 4.
C	02/05/2014	SHEET 3: ADDED VIEW AND P/N TABLE FOR CLOSED TOP W/LP. SHEET 4/5: EXPANDED ALLOWABLE AREA WHERE SURFACE TRACES ARE PERMITTED. REMOVED "HOLE PATTERN REPEATS FOR EACH PORT." FROM NOTE 4
D	07/15/2014	SHEET 1: ADDED MATERIAL INFORMATION TO NOTES. SHEET 2: MADE HEATSINK HEIGHT DIMENSIONS REF. CHANGED REARMOST LEG ON BOTH SIDES OF ALL CAGES FROM 3D PRESSFIT TO EYE-OF-THE-NEEDLE PRESSFIT LEG.
E	10/6/2014	ADDED 2 ROW QUAD LIGHT PIPE OPTION SHEET 2: CHANGED HEATSINK HEIGHT DIMENSIONS TO REF J14: DIM 67.48 CHANGED TO REF SHEET 4: MOVED DATUMS "K" AND "L" TO CONNECTOR HOLES REMOVED BASIC FROM "0.00" POSITIONS SHEET 5: MOVED DATUMS "K" AND "L" TO CONNECTOR HOLES REMOVED BASIC FROM "0.00" POSITIONS H18: MADE HOLE DIAMETER DIMENSION TYP SHEET 7: EDIT NOTE 1, REMOVED "SIZE" REMOVED NOTE 1 FROM ALL "10.15" DIMENSIONS
F	3/12/2015	ADDED 1000171255 & LIGHT PIPE FEATURE IN COLUMN @ M10 ON SHEET3.
G	04/14/2015	SHEET 4: REVISED DIM "WAS" 12.77 "NOW" 12.79 @G9 REVISED FRAMED TEXT NUMBER 4 TRIANGLES TO FRAMED TEXT NUMBER 5 @D5, @E4, @E6, @F4, @F6, AND @H7 SHEET 5: REVISED DIM "WAS" 12.77 "NOW" 12.79 @F7 REMOVED NOTE 4 AND REVISED NOTE 5 TO NOTE 4 REMOVED NOTE 4 @A20 REMOVED SEE NOTE 4 AND ADDED DIMS @K11, K12, K13, AND @K14 SHEET 6: REVISED PORT CL "WAS" (4) "NOW" PORT CL @E7, D17, G17 AND @H7
H	06/16/2015	SHEET 1: C7: CHANGED YR FROM 12,13,14 ETC.(EXAMPLE: YEAR 2012=12) TO 15,16,17 ETC.(EXAMPLE: YEAR 2015=15) SHEET 3: B18: ADDED PN 1000171649 CUSTOM H/S 19mm TO HEATSINK AND LIGHT PIPE TABLE SHEET 6: CHANGED REVISION DESCRIPTION FROM ENTER DESCRIPTION TO SEE REVISION TABLE CHANGED MATERIAL NO. FROM 9999999999 TO SEE DRAWING
J	06/26/2015	REMASTERED FROM SD-100017-1200_REV-H
J1	01/04/2016	UP-REVISIED TO CORRECT THE MODEL
J2	01/07/2016	CHANGED DOCUMENT FROM RSD TO SD
J3	2016/01/15	UPDATE DRAWING FORMAT TO NEW SIZE D SHEET 7 & 8: ADDED NOTE: THIS DIMENSION IS FOR REFERENCE ONLY. USER CAN MODIFY IT DEPENDS ON APPLICATION. (THIS DIMENSION VARIES BASED ON DISTANCE OF " HOLE OF ADIACENT CAGE" ON PCB LAYOUT.)
K	2017/06/07	SHEET 4: ADDED PAD TO HOLES & UPDATED VIEWS TO AVOID CONFUSION SHEET 5: ADDED PAD TO HOLES & UPDATED VIEWS TO AVOID CONFUSION C05: ADDED BASIC DIM 19.52 C10: ADDED BASIC DIM 35.28 & 38.52 C12: ADDED BASIC DIM 54.28 & 57.52 C13: ADDED BASIC DIM 72.78 SHEET 6: ADDED PAD TO HOLES & UPDATED VIEWS TO AVOID CONFUSION SHEET 7: J03: CHANGED DIM FROM 9.78 REF TO 9.75 REF SHEET 8: J03: CHANGED DIM FROM 9.78 REF TO 9.75 REF
K1	2019/08/26	OBSOLETED P/N 1000171240,1000171255,1000171448,1000171543,1000171647.
L	2020/08/17	REACTIVATED P/N 1000171255

THIS DRAWING CONTAINS INFORMATION THAT IS PROPRIETARY TO MOLEX ELECTRONIC TECHNOLOGIES, LLC AND SHOULD NOT BE USED WITHOUT WRITTEN PERMISSION									
DIMENSION UNITS	SCALE	CURRENT REV DESC: REACTIVATED PART NUMBER							
mm	1:1	 ZQSFP+ 1X4 GANGED CAGE ASSY'S (SPRING FINGER) WITH H/S & L/P OPTIONS  PRODUCT CUSTOMER DRAWING							
GENERAL TOLERANCES (UNLESS SPECIFIED)									
ANGULAR TOL	± 1.0°								
4 PLACES	±								
3 PLACES	±								
2 PLACES	± 0.13	EC NO: 643481	2020/08/17		2020/08/25		2020/08/25		
1 PLACE	± 0.25	DRWN: AKUMAR19	2020/08/25		CHK'D: GB		2020/08/25		
0 PLACES	±	APPR: GB	2020/08/25		INITIAL REVISION:		DOCUMENT NUMBER		
DRAFT WHERE APPLICABLE MUST REMAIN WITHIN DIMENSIONS		DRWN: KNAGANNA	2015/06/03		APPR: RCHEN08		2016/01/11		
THIRD ANGLE PROJECTION		DRAWING		SERIES	MATERIAL NUMBER	CUSTOMER	SHEET NUMBER		
		D-SIZE		100017	SEE TABLE	GENERAL MARKET	9 OF 9		

DOCUMENT STATUS	P1	RELEASE DATE	2020/08/25	04:10:24
-----------------	----	--------------	------------	----------