

PART NUMBER	REV	FIRST USED
1385365-1	B	122500-1
1385365-2	A	565435-5

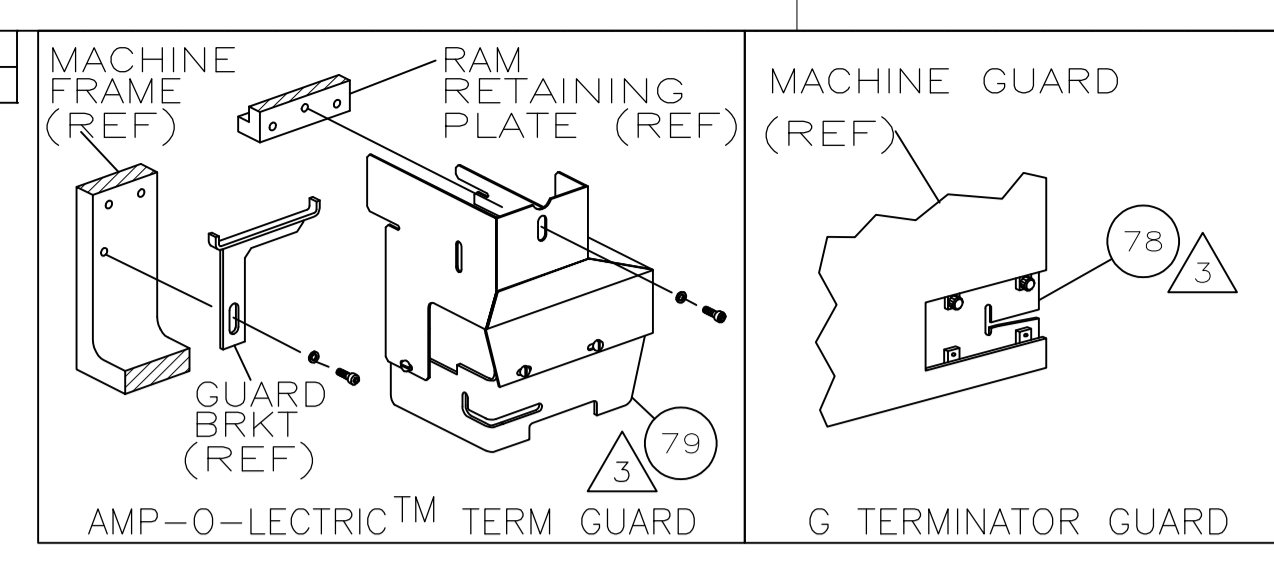

AMP PN		MFR PN		GROTE HARTMAN TERMINAL		AMP CRIMP SPECS	
1572042	25266.123.211	PAD LTR		CRIMP HEIGHT		WIRE SIZE	
1949656-1	25211.212.179						
		A		.119 ±.002 [3.02 ±0.05mm]		10	
		B		.102 ±.002 [2.59 ±0.05mm]		12	
		C		NOT		USED	
		D		NOT		USED	
		CRIMP		SIZE		TYPE	
		WIRE		.140 [3.56mm]		F	
		INSUL		.200 [5.08mm]		F	
						.160 MAX	
WIRE STRIP LENGTH		TERM APPL SPEC		FEED		APPL INSTRUCTION	
.218		NONE		1.035		408-8039	
				SET UP GAGE		LAYOUT	
				458638-1		L2613	

LOC	DIST	REVISIONS			
A	66	REV	DESCRIPTION	DATE	BY
		B1	ECR-08-006284	3-2008	MY

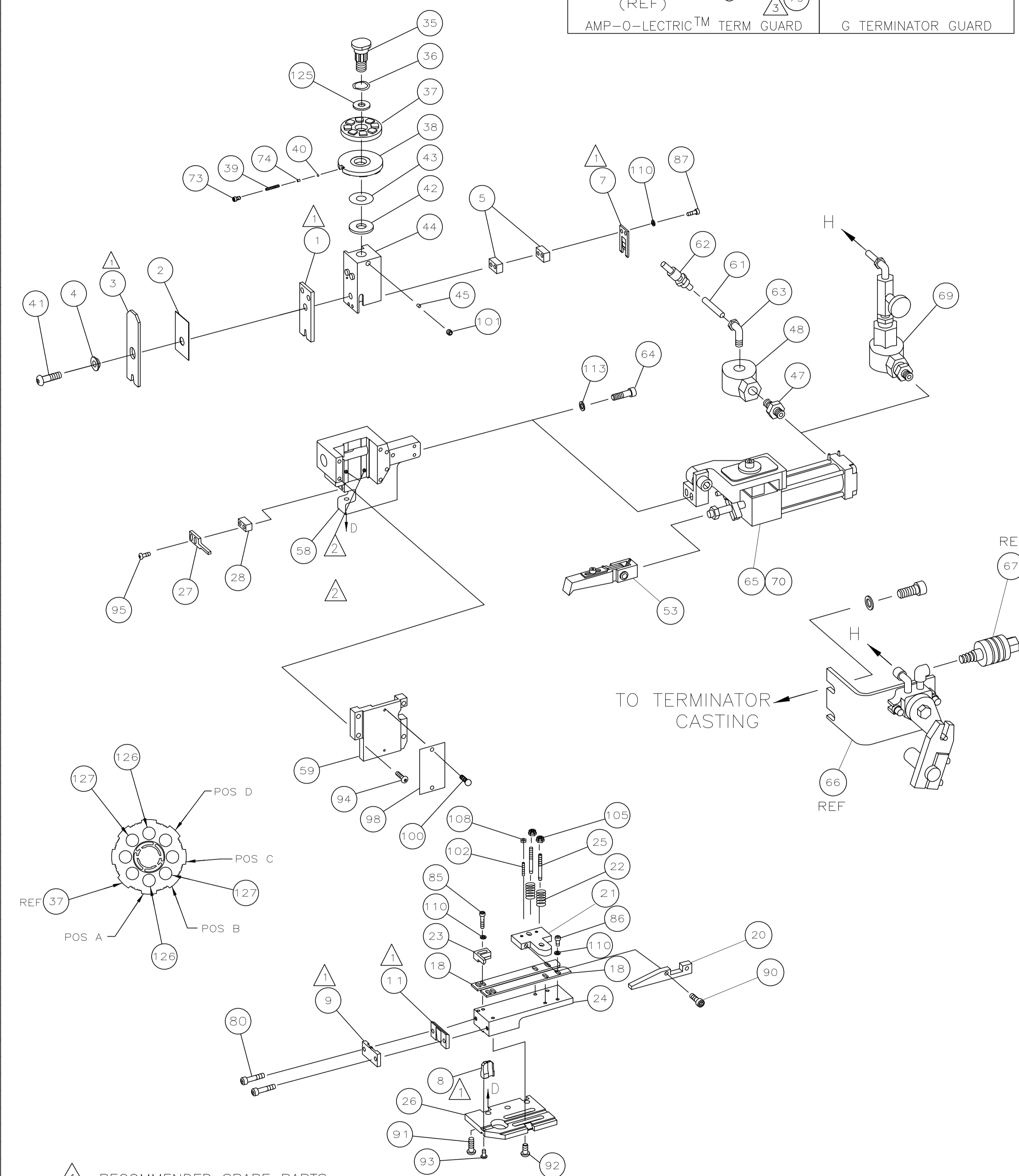

QTY	REV	DESCRIPTION	ITEM NO	
			129	
			128	
2	2	3-354778-7	PIN, WIRE DISC (.2680)B	127
2	2	354778-1	PIN, WIRE DISC (.2500)A	126
1	1	986950-1	WASHER, FLAT PRECISION	125
1	1	217238-1	GENERAL INSTRUCTION PACKAGE	124
1	1	4088039	EF APPL INST 408-8039	123
			122	
			121	
			120	
			119	
			118	
			117	
			116	
			115	
			114	
2	2	21024-5	WASHER,LOCK(#10)AIR ASSY	113
			112	
			111	
7	7	21024-4	WASHER,LOCK(NO.8)SHEAR BL	110
			109	
2	2	21018-4	NUT,HEX(4-40)DRAG	108
			107	
			106	
2	2	21022-2	NUT,HEX SL(8-32)DRAG STUD	105
			104	
			103	
2	2	2-21006-6	SCR,SKT SET(4-40x.62)DRAG	102
1	1	21009-2	SCR,SKT SET(1/4-20x.25)RAM	101
2	2	21017-2	SCR,DRIVE(#2x.19)ID PLATE	100
			99	
1	1	461264-1	PLATE, IDENTIFICATION	98
			97	
			96	
2	2	2-21002-2	SCR,BHC(8-32x.50)STRIPPER	95
4	4	2-21002-9	SCR,BHC(10-32x.75)CAP	94
1	1	22733-8	SCR,BHC(8-32x.38 LW)ANVIL	93
4	4	3-21002-3	SCR,BHC(1/4-20x.50)ST GD PL	92
3	3	2-22733-8	SCR,BHC(1/4-20x.62)HSG	91
2	2	1-21000-3	SCR,SHC(4-40x.25)DRAG	90
			89	
			88	
2	2	2-21000-8	SCR,SHC(8-32x.62)SLUG BLADE	87
3	3	2-21000-6	SCR,SHC(8-32x.38)STRIP GUIDE	86
2	2	2-21000-9	SCR,SHC(8-32x.75)R STRIP GUIDE	85
			84	
			83	
			82	
			81	
2	2	3-21000-8	SCR,SHC(10-32x.88)SHEAR PL	80
1	-	455750-7	GUARD ASSY	79
-	REF	679532-1	INSERT, GUARD	78
			77	
			76	
			75	
1	1	690603-1	SPRING, ASSIST	74
1	1	23030-1	SCR,SKT CAP(6-32x.25)CP DSC	73
			72	
			71	

-1	LEADMAKER & BENCH MODEL G	AIR FEED
-2	BENCH MODEL K	AIR FEED

QTY	REV	DESCRIPTION	ITEM NO	
			70	
			69	
			68	
			67	
			66	
			65	
			64	
			63	
			62	
			61	
			60	
1	1	454220-1	CAP, RAM	59
1	1	453736-1	HOUSING	58
			57	
			56	
			55	
			54	
4	1	460680-1	FEED FINGER ASSY	53
			52	
			51	
			50	
			49	
-	1	22374-7	VALVE, QUICK EXHAUST	48
-	1	22304-1	NIPPLE,HEX 1/8 NPT	47
			46	
1	1	690191-1	PLUG, NYLON	45
1	1	455674-1	RAM	44
1	1	690125-1	WASHER, LAMINATED	43
1	1	690124-7	WASHER, RAM	42
1	1	7-21002-9	BOLT, CRIMPER(5/16-24x1.00)	41
1	1	23241-6	BALL, STEEL	40
1	1	690170-1	SPRING, COMPRESSION	39
1	1	1-690142-0	DISC, INSULATION	38
1	1	354777-1	WIRE DISC, PLASTIC	37
1	1	22480-5	WASHER, SPRING	36
1	1	690212-1	POST, RAM	35
			34	
			33	
			32	
			31	
			30	
			29	
1	1	3-690451-2	SPACER, STRIPPER	28
1	1	240639-1	STRIPPER	27
1	1	455676-1	PLATE, BASE	26
2	2	22354-8	DRAG, STUD	25
1	1	455678-1	PLATE, STRIP GUIDE	24
1	1	240825-8	PLATE, STRIP HOLD DOWN	23
2	2	4-22281-1	SPRING, DRAG	22
1	1	464451-1	ARM, STOCK DRAG	21
1	1	464452-4	DRAG, STOCK	20
			19	
2	2	1-454204-0	GUIDE, STRIP (FRONT)	18
			17	
			16	
			15	
			14	
			13	
			12	
1	1	240644-1	PLATE, REAR SHEAR	11
			10	
1	1	690482-5	PLATE, FRONT SHEAR	9
1	1	8-461295-8	ANVIL	8
1	1	690474-5	BLADE, SLUG	7
			6	
2	2	1-240641-0	SPACER, SLUG BLADE	5
1	1	1-238009-1	SPACER, BLOCK CRIMPER	4
1	1	3-1213077-2	CRIMPER, INSULATION	3
1	1	1-455888-4	SPACER, CRIMPER	2
1	1	456425-9	CRIMPER, WIRE	1

- 1 RECOMMENDED SPARE PARTS.
- 2 GREASE LIGHTLY.
- 3 GUARD MUST BE IN PLACE WHEN OPERATING APPLICATOR IN A BENCH MACHINE.
- 4 SEE DRAWING FOR COMPONENTS
- 5 ITEM 78 USED WITH G TERMINATOR ONLY.

QTY REQD PER ASSY	REV	DESCRIPTION	ITEM NO
-3	-2	-1	U/M

QTY REQD PER ASSY	REV	DESCRIPTION	ITEM NO
-2	-1	U/M	

THIS DRAWING IS A CONTROLLED DOCUMENT.

APPROVED: R. KNEPPER, Tyco Electronics Corporation, Harrisburg, PA 17105-3608

APPROVED: J. ELBIN

END FEED HDM APPLICATOR

SIZE: A1, CAGE CODE: 00779, DRAWING NO: 1385365

CUSTOMER DRAWING