

PAGE 1/3	ISSUE 21-12-15B	SERIES SMP	PART NUMBER R222645700
----------	-----------------	-------------------	-------------------------------

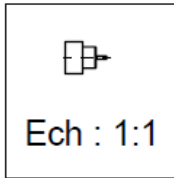

All dimensions are in mm.

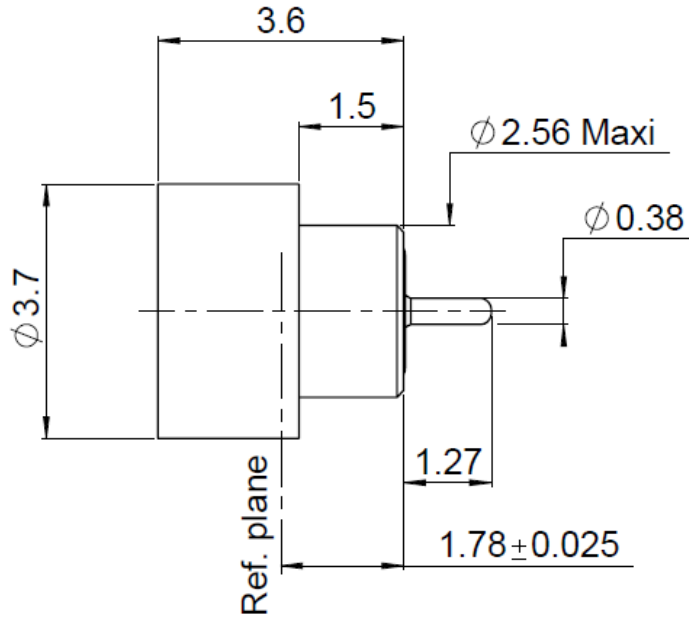
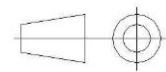

COMPONENTS	MATERIALS	PLATING (µm)
Body	DILVER P1	GOLD OVER NICKEL
Center contact	DILVER P1	GOLD OVER NICKEL
Outer contact		
Insulator	GLASS	
Gasket		
Others parts		
-	-	-
-	-	-

PAGE 2/3	ISSUE 21-12-15B	SERIES SMP	PART NUMBER R222645700
----------	-----------------	------------	------------------------

PACKAGING

Standard	Unit	Other
100	Contact us	Contact us

ELECTRICAL CHARACTERISTICS

Impedance		50	Ω
Frequency		0-40	GHz
VSWR	1.15* +	0.0000	x F(GHz) Maxi
Insertion loss		0.12	√F(GHz) dB Maxi
RF leakage	- (- F(GHz)) dB Maxi
Voltage rating		335	Veff Maxi
Dielectric withstanding voltage		500	Veff mini
Insulation resistance		5000	MΩ mini

ENVIRONMENTAL

Operating temperature	-65/+165	°C
Hermetic seal	10-8	Atm.cm3/s
Panel leakage	NA	

MECHANICAL CHARACTERISTICS

Center contact retention			
Axial force – Mating End		6.8	N mini
Axial force – Opposite end		6.8	N mini
Torque		NA	N.cm mini
Recommended torque			
Mating		NA	N.cm
Panel nut		NA	N.cm
Mating life		1000	Cycles mini
Weight		0.0950	g

SPECIFICATION

OTHER CHARACTERISTICS

Assembly instruction:

Others:
* to 18GHz

PAGE 3/3	ISSUE 21-12-15B	SERIES SMP	PART NUMBER R222645700
----------	-----------------	------------	------------------------

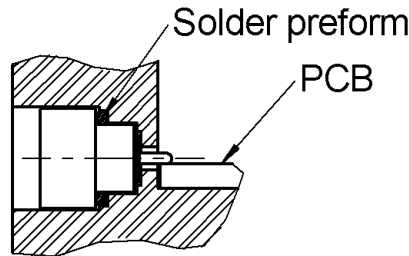

1. Degrease and clean connector and box
2. Solder the connector on the panel
we advise SnAg4 Cu0.5, we recommend a low residue flux. Preheating at 100 °C. Take care not to exceed 260°C during solder operation
3. Solder the pin on the track
we advise SnAg4 Cu0.5, we recommend a low residue flux. Preheating at 100 °C (only for ceramic substrate). Take care not to exceed 260°C during solder operation

Panel mounting hole

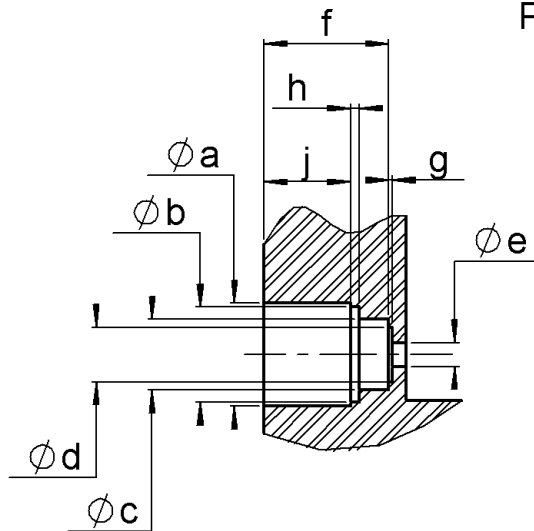

a	3,76 - 3,78
b	3,43 - 3,55
c	2,59 - 2,61
d	1,95 - 2,05
e	0,87 - 0,91
f	4,55 - 4,59
g	0,13 - 0,17
h	0,28 - 0,38
j	3,15 - 3,19