



BeStar Technologies Inc.

Address: 761 N. 17th Street Unit 4, St. Charles, IL 60174

Tel : 847-261-2850 E-mail : sales@bestartech.com Web : www.bestartech.com

Document Number : 0810-71
Revision : A6
Total Pages : 6
Prepare by : Loki, **Lo**
Date : 28 November, 2016

SoniCrest Brand Acoustic Components

www.jlsonicrest.com

Document Type : Specification
Product Type : SMD Piezo Sound Generator Component
Part Number : HPS22A

A1 - New issue created by Holmes, Poon on 20 Oct., 2008	A5 - Updated section 4 ~ 7 by Loki, Lo on 29 Jul., 2015	
A2 - Updated section 4 by Ting Lok, Ngan on 12 Jan., 2011	A6 - Updated section 4, 5, 7, 8 by Loki, Lo on 28 No., 2016	
A3 - Updated section 7 & 8 by Holmes, Poon on 21 Sept., 2011		
A4 - Updated section 4 by Holmes, Poon on 18 Oct., 2011		

This material is the property of BeStar Technologies Inc.
Unauthorized copying or use of this material is prohibited.

1. Purpose and Scope

This document contains both general requirements, qualification requirements, and those specific electrical, mechanical requirements for this part.

2. Description

Ø22mm SMD piezo sound generator, RoHS compliant.

3. Application

Telecommunication Equipment, Computers and Peripherals, Portable Equipment, Automobile Electronics, POS System, etc.

4. Component Requirement

4.1. General Requirement

- 4.1.1. Operating Temperature Range : -20°C to +85°C
- 4.1.2. Storage Temperature Range : -30°C to +90°C
- 4.1.3. Housing material : PPS

4.2. Electrical Requirement

- 4.2.1. Rated Voltage : 9Vp-p
- 4.2.2. Operating Voltage : 2 ~ 30 Vp-p
- 4.2.3. Rated Current : <=5mA
- 4.2.4. Capacitance at 1KHz : 20 ± 30% nF
- 4.2.5. Sound Pressure level at 10cm
(Applying rated voltage and 4000Hz) : >=100dB
- 4.2.6. Resonant Frequency : 4000 ± 500Hz

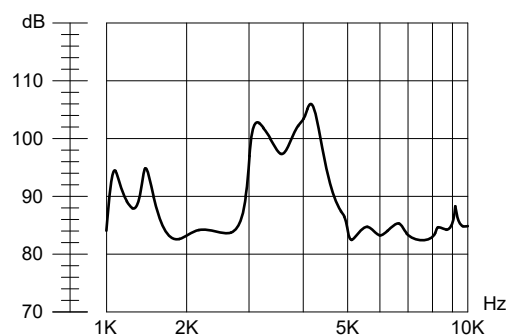

Figure 1. Frequency Response

4.3. Mechanical Requirement

- 4.3.1. Layout and Dimension : See Section 7, Figure 4

4.4. Test Setup

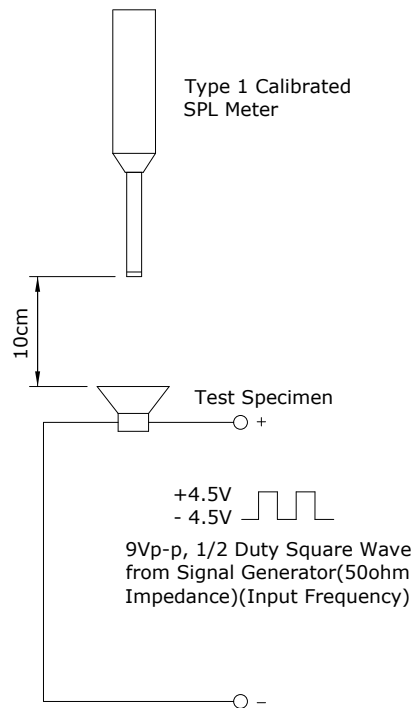

Figure 2. Test Setup

Notes : Apply 9Vp-p from Signal Generator, set 4000Hz from Signal Generator. Measure SPL using a calibrated SPL meter 10cm from the alert port. Sound level meter to be in accordance with IEC651 (1979) Type 1 and/or ANSI S1.4-1983. The meter must be checked on a daily basis using a calibrated acoustic calibrator recommended by the manufacturer. Measurement should be carried out in a free field environment or at least 40cm from any surface.

5. Reliability Test

- 5.1. High Temperature** : Subject samples to +85°C for 4 hours. Components must be fully stabilized at temperature extremes before data is taken, which may require up to a 2 hours soak.
- 5.2. Low Temperature** : Subject samples to -40°C for 4 hours. Components must be fully stabilized at temperature extremes before data is taken, which may require up to a 2 hours soak.
- 5.3. Temperature Shock** : Each temperature cycle shall consist of 30 minutes at -40°C, 15 minutes at +20°C, 30 minutes at +85°C and 15 minutes at +20°C. Test duration is for 5 cycles. Components must be fully stabilized at temperature extremes before data is taken, which may require up to a 2 hours soak.
- 5.4. Static Humidity** : Precondition at room temperature for 1 hour. Then expose to +40°C with 90 ~ 95% relative humidity for 24 hours. Finally dry at room ambient for 2 hours before taking final measurement.
- 5.5. Random Vibration** : Secure samples. Vibrated randomly 10 ~ 55Hz with 1.5mm peak amplitude in 3 directions (x, y and z). The test duration is 2 hours per plane.
- 5.6. Drop Test** : Drop samples naturally from the height of 80cm onto a 5cm thickness wooden board in 3 directions (x, y and z).
- 5.7. Solderability** : Immerse solder pads into molten solder at 250 ± 5 °C for 10 ± 1 second. After testing covered area of pins should be $\geq 90\%$ with a continuous coating of bright solder.

6. Recommended Reflow Process Condition

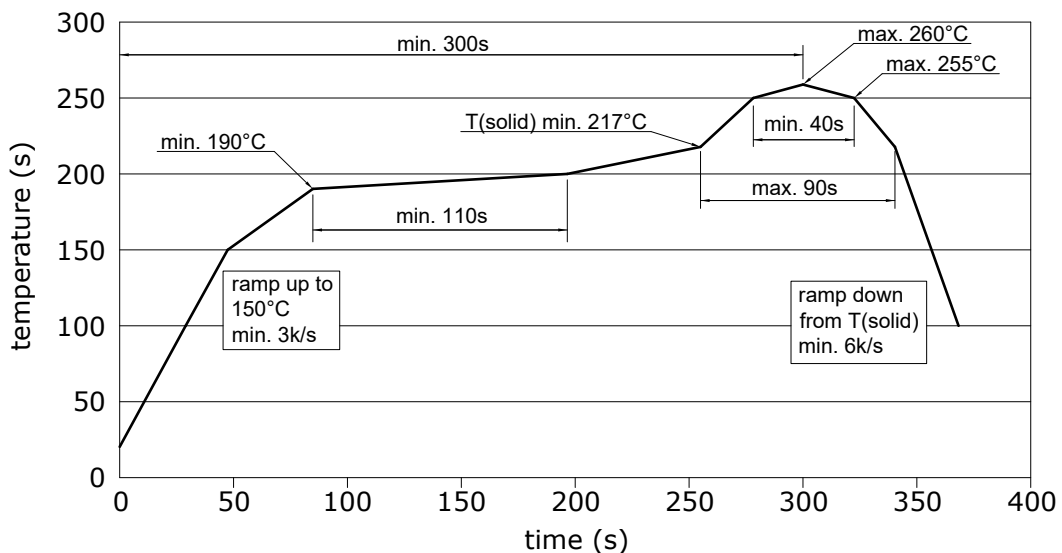

Figure 3. Recommended reflow oven temperature profile

7. Mechanical Layout

Unit : mm

Tolerance : Linear XX.X = ±0.3
 XX.XX = ±0.05
 Angular = ±0.25°
 (unless otherwise specified)

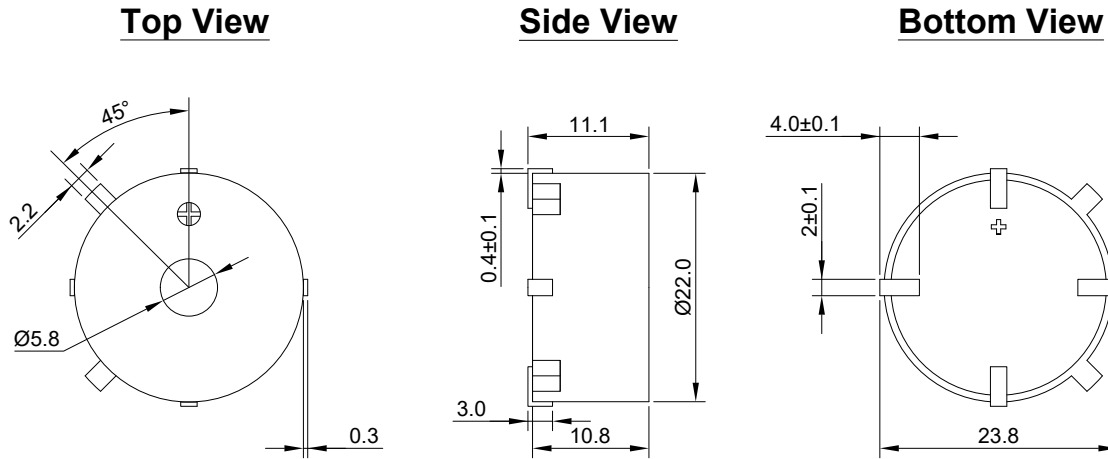

Figure 4. HPS22A Mechanical Layout

8. Standard Packing Layout

8.1. Tape Layout

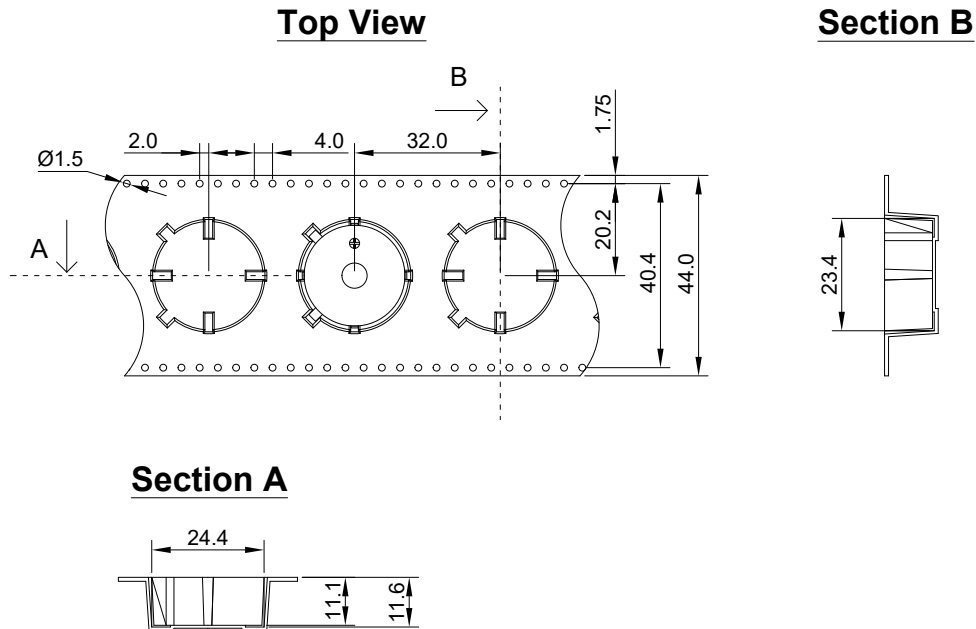

Figure 5. Tape Layout

8.2. Reel Layout

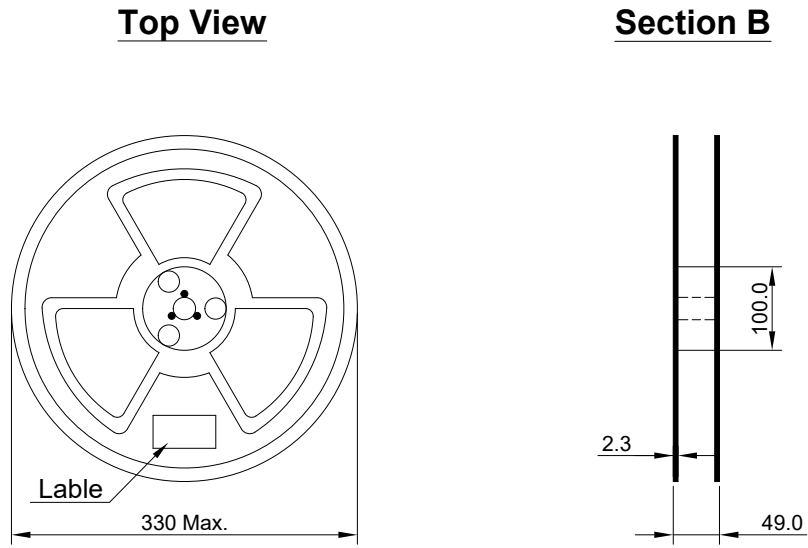

Figure 6. Reel Layout

8.3. Packing Quantity : 150 pieces per reel, 3 reels per carton (Total 450 pieces)

8.4. Carton Size : 37.5 x 37.5 x 23.5 cm

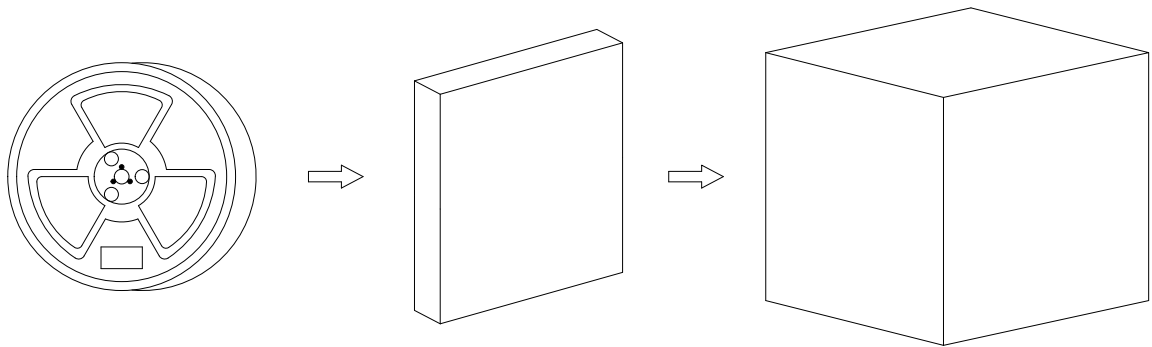

Figure 7. Reels Installation