

PART NUMBER	REVISION	DESCRIPTION	FEED TYPE
2151040-1	D	FINE CRIMP HEIGHT ADJUST	MECHANICAL
2151040-2	D	FINE CRIMP HEIGHT ADJUST	PNEUMATIC
7-2151040-1	D	MECHANICAL AND CRIMP TOOLING KIT	MECHANICAL
7-2151040-2	D	PNEUMATIC AND CRIMP TOOLING KIT	PNEUMATIC
7-2151040-7	B	CRIMP TOOLING KIT	-

ATLANTIC VERSION TERMINATOR INTERFACE ADAPTER

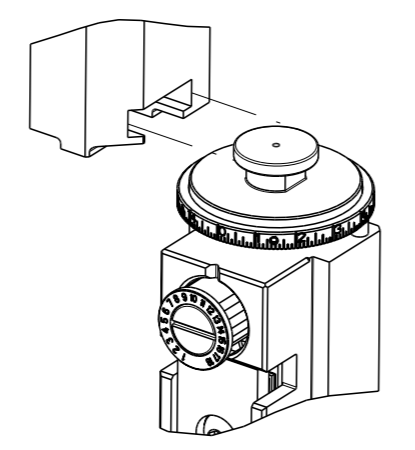

APPLICATOR DATA		
CRIMP	SIZE	TYPE
WIRE	1.40 mm [.055]	F
INSUL	2.03 mm [.080]	O

APPLICATOR INSTRUCTIONS
408-35042

TERMINAL DATA: TE TERMINAL		TE CRIMP SPECIFICATION	
TERMINAL NAME: AMP MCP 2.8K FLAT TYPE RECEPTACLE			
WIRE STRIP LENGTH		INSULATION DIAMETER RANGE	
3.10-3.70 mm [.122-.146 IN]		Ø1.10-1.40 mm [.043-.055 IN]	
TERMINAL APPLICATION SPECIFICATION	114-18387		
TERMINALS APPLIED			
TE TERMINAL	TE TERMINAL	TE TERMINAL	TE TERMINAL
1241386-1	1241386-2	1241386-3	

WIRE SIZE	CRIMP HEIGHT mm [INCH]	CRIMP HEIGHT REFERENCE SETTING
0.35mm2	1.03+/-0.03 [.041+/- .001]	7.2
0.25mm2	0.98+/-0.03 [.039+/- .001]	7.6
0.22mm2	0.96+/-0.03 [.038+/- .001]	8.1
0.20mm2	0.96+/-0.03 [.038+/- .001]	8.1

- RECOMMENDED SPARE PARTS
- REFER TO SUPPLIED INSTRUCTION SHEET FOR CLEANING, LUBRICATION & STORAGE OF APPLICATOR.
- APPLY PART NUMBER 2-23419-6 LOCTITE TO THREADS OF ITEM 242.
- CRIMP HEIGHT REFERENCE SETTING WAS THE SETTING USED WHEN THE APPLICATOR WAS QUALIFIED AT THE FACTORY. ADJUSTMENT MAY BE NECESSARY WHEN RUNNING APPLICATOR IN THE FIELD.
- TERMINAL LUBRICANT IS RECOMMENDED.
- 6. UNLESS SPECIFIED OTHERWISE TORQUE VALUES SHALL BE USED PER DOCUMENT 101-35000.

***WARNING**
 ON INSTALLATION, SET WIRE DISC TO CRIMP HEIGHT REFERENCE SETTING FOR LARGEST WIRE SIZE. CRIMP HEIGHT REFERENCE SETTINGS GREATER THAN THE VALUE SHOWN MAY CAUSE DAMAGE TO THE CRIMP TOOLING, REFER TO THE INSTRUCTION SHEET FOR PROPER SETUP AND ADJUSTMENTS.

ATLANTIC VERSION
 Shown on sheets 1 of 4 & 2 of 4
 (Pacific version shown on sheets 3 of 4 & 4 of 4)

REVISONS		DATE	OWN	APVD
B	ECR-13-002383	07FEB2013	L.Z	S.X
B1	ECR-15-002036	06FEB2015	YY	UG
C	ECR-17-010770	25JULY2017	RS	LZ
D	ECR-19-003861	11MAR2019	LG	TE

-	1	-	1	-	2119640-1	PUSH ROD, AIR FEED	250
-	1	-	1	-	1803259-1	BUSHING, FLANGED	249
-	1	-	1	-	2119641-1	FEED CAM, AIR FEED	248
-	1	1	1	1	2119082-9	CAM, SNAIL, INSULATION ADJUSTMENT	244
-	1	1	1	1	2079764-1	WASHER, WAVE SPRING, CREST-TO-CREST	243
-	1	1	1	1	2119083-1	RETAINER, INSULATION DIAL	242
-	1	1	1	1	7-18023-7	SCR, SKT HD CAP M3 X 4.0	241
-	-	1	-	1	2119580-1	MECHANICAL FEED ASSEMBLY	239
-	1	-	1	-	2063440-1	AIR FEED MODULE	238
-	2	-	2	-	21045-3	RING, RETAIN, EXTERN, 3/16 CRESCENT	172
-	REF	REF	REF	REF	994970-2	COUNTER, MAGNETIC	164
-	1	-	1	-	240638-1	SPRING, FEED FINGER	163
-	1	-	1	-	3-23627-7	PIN, RETAIN, GRVD, 3/16 X .854	137
-	1	-	1	-	2119799-1	HOLDER, FEED FINGER, AF	136
-	1	1	1	1	1-18028-2	WASHER, FLAT, REG M4	119
-	1	1	1	1	2119955-1	ASSY, LUBRICATOR, SIDE FEED	113
-	1	1	1	1	2844908-1	SCREW, LOCKING	99
-	1	1	1	1	2844907-1	POST, LOCKING	98
-	1	1	1	1	455888-5	SPACER, CRIMPER	82
-	1	1	1	1	1803607-1	DOCUMENTATION PACKAGE	71
-	1	1	1	1	2119740-1	TAG, IDENTIFICATION	67
-	2	2	2	2	2168078-1	SCREW, DRIVE, RH, RoHS, 2 x .188	66
-	1	1	1	1	2168083-2	SCR, SKT HD CAP, RoHS, M4 X 8.0	60
-	1	1	1	1	5-18022-5	SCR, HEX HD CAP, M4 X 6.0	59
-	1	1	1	1	1338685-1	PAWL, FEED	56
-	4	4	4	4	2168083-3	SCR, SKT HD CAP, RoHS, M4 X 12.0	54
-	2	2	2	2	2-2168083-5	SCR, SKT HD CAP, RoHS, M4 X 14	53
-	1	1	1	1	1803382-2	HOLD DOWN, SPRING LOADED	50
-	1	2	1	2	18023-9	SCR, SKT HD CAP M4 X 6.0	49
-	-	1	-	1	2119652-1	FEED CAM, PRE FEED	48
-	-	1	-	1	2119653-1	FEED CAM, POST FEED	47
-	1	1	1	1	1803583-9	APPLICATOR BASIC ASSEMBLY, SF	46
-	1	1	1	1	1803515-1	RAM ASSEMBLY, SF ATLANTIC	44
-	1	1	1	1	1803602-1	SCR, BHSC, RoHS (M8 X 25)	41
-	1	1	1	1	1-1752356-7	SUPPORT, TERMINAL	34
-	2	2	2	2	2079383-5	SCR, BHSC, RoHS (M4 X 20)	33
-	2	2	2	2	2-2844962-6	SPACER, CYLINDRICAL, STRIP GUIDE	30
-	1	1	1	1	2844992-2	ASSEMBLY, STRIP GUIDE	29
-	1	1	1	1	1-455888-0	SPACER, CRIMPER	28
-	1	1	1	1	1320928-2	STRIP GUIDE	24
-	1	1	1	1	2168083-2	SCR, SKT HD CAP, RoHS, M4 X 8.0	21
-	1	1	1	1	1-18028-2	WASHER, FLAT, REG M4	20
-	1	1	1	1	2119533-1	STRIPPER, SIDE FEED	19
-	1	1	1	1	2119806-1	INSERT, SHEAR	13
-	1	1	1	1	3-22280-3	SPRING, COMPRESSION	12
-	1	1	1	1	1-356885-4	STOP, SHEAR	11
-	1	1	1	1	2119805-1	SHEAR HOLDER, FRONT	10
-	1	1	1	1	1803095-6	FLOATING SHEAR, FRONT	9
1	2	2	1	1	2-1333201-4	ANVIL, COMBINATION	8
-	1	1	1	1	2119757-8	DEPRESSOR, SHEAR	5
-	1	1	1	1	1-238011-0	BLOCK, CRIMPER SPACER	4
1	2	2	1	1	2119784-3	CRIMPER, INSULATION O PREMIUM	3
-	1	1	1	1	455888-3	SPACER, CRIMPER	2
1	2	2	1	1	456402-1	CRIMPER, WIRE PREMIUM	1

DIMENSIONS: mm		TOLERANCES UNLESS OTHERWISE SPECIFIED:		OWN: C. CHEN 18MAR2011		TE Connectivity Harrisburg, PA 17105-3608	
mm		0 PLC ±		CHK: S.XI 18MAR2011		NAME: Ocean Side Feed Applicator	
		1 PLC ±		APVD: J. CRUZ 18MAR2011		SIZE: A1	
		2 PLC ±		PRODUCT SPEC		CAGE CODE: 00779	
		3 PLC ±		APPLICATION SPEC		DRAWING NO: 2151040	
		4 PLC ±		MATERIAL		SCALE: 1:2	
		FINISH		WEIGHT		SHEET 1 OF 4	
				CUSTOMER ACCESSIBLE PRODUCTION DRAWING		REV D	

LOC	DIST	REVISIONS					
A	66	P	LYR	DESCRIPTION	DATE	OWN	APVD
		-		SEE SHEET 1	-	-	-

FEED TYPE MECHANICAL

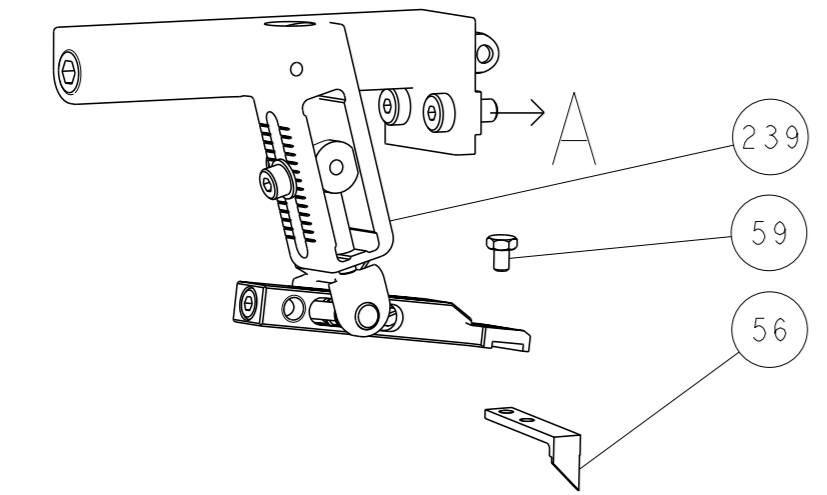

PNEUMATIC

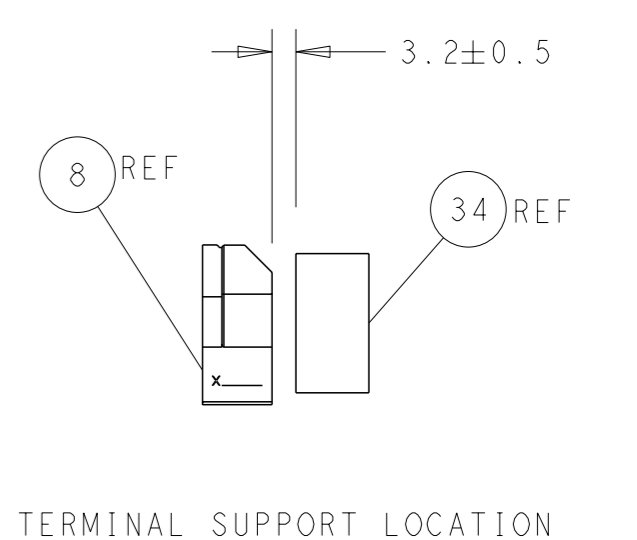
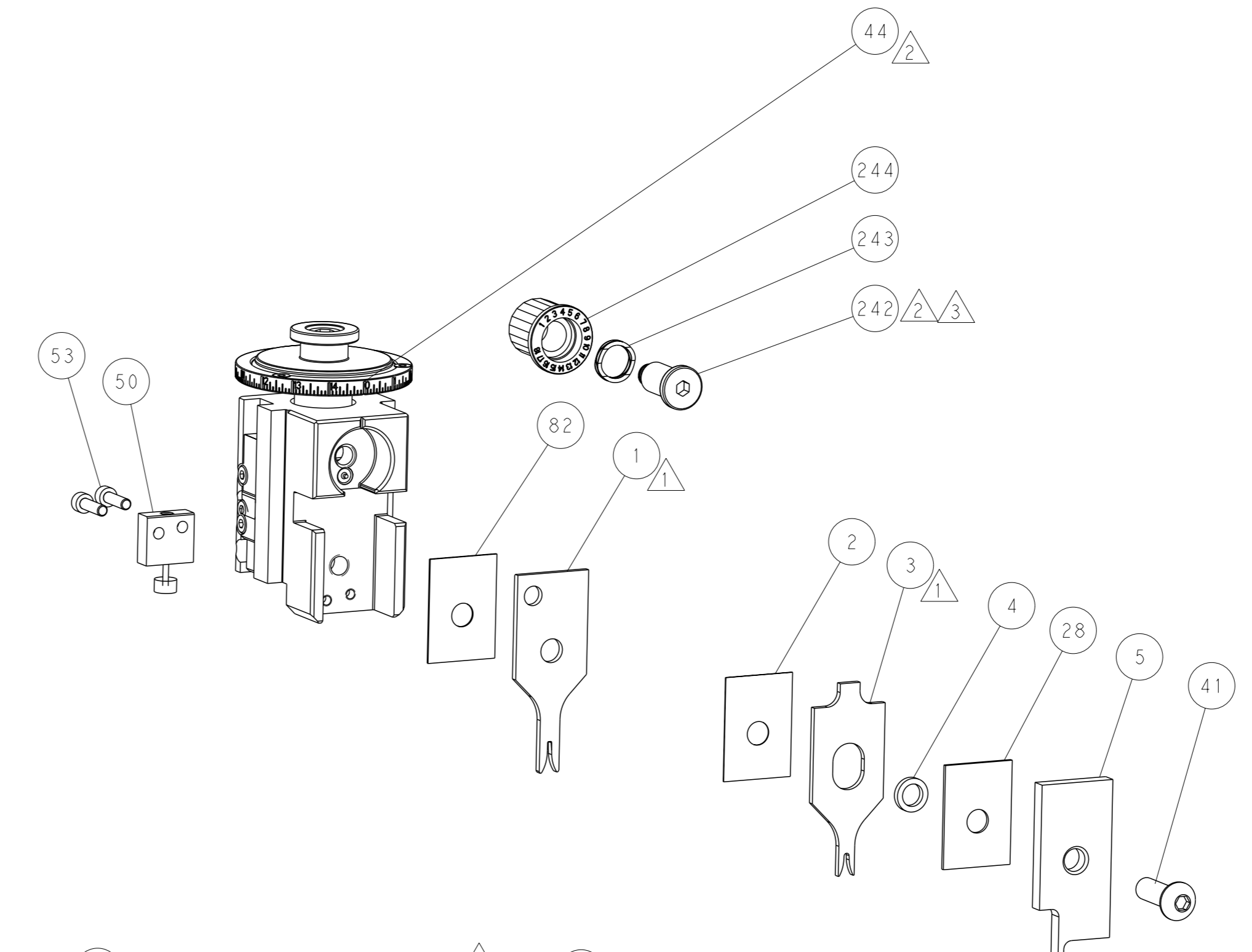
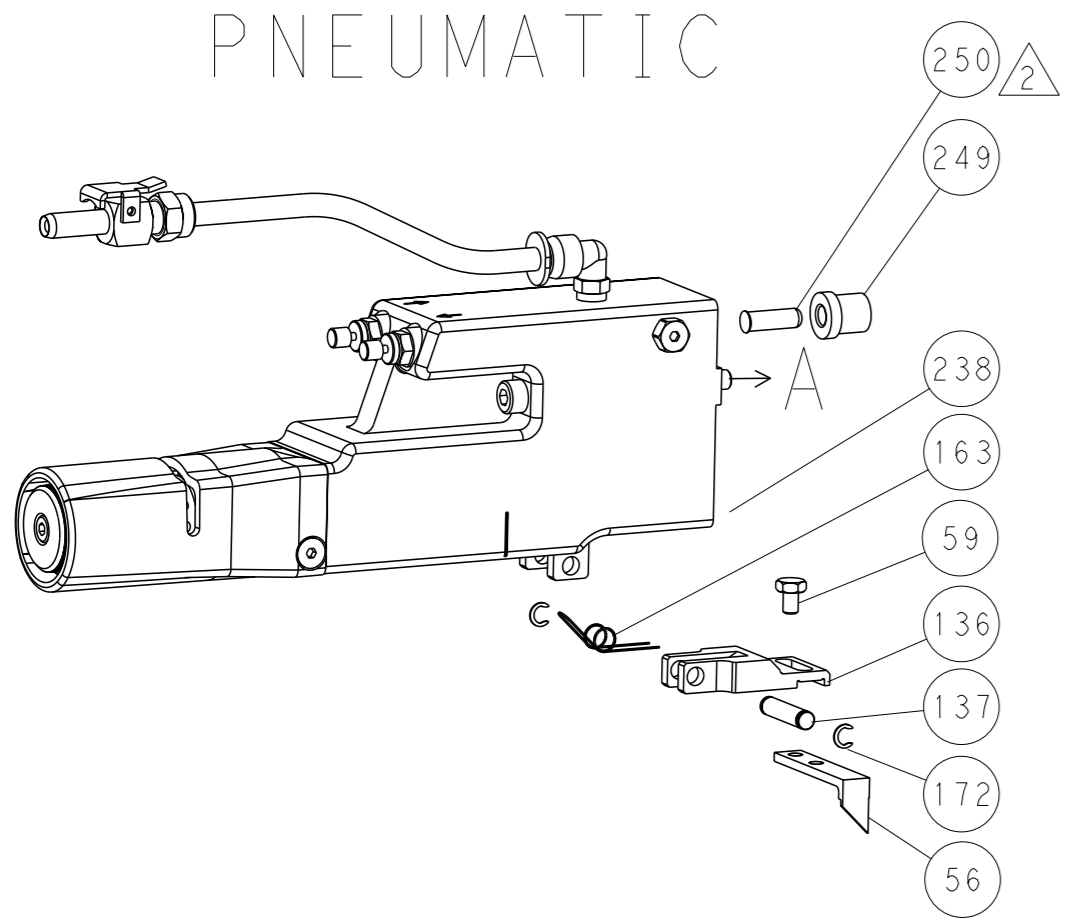

TERMINAL SUPPORT LOCATION

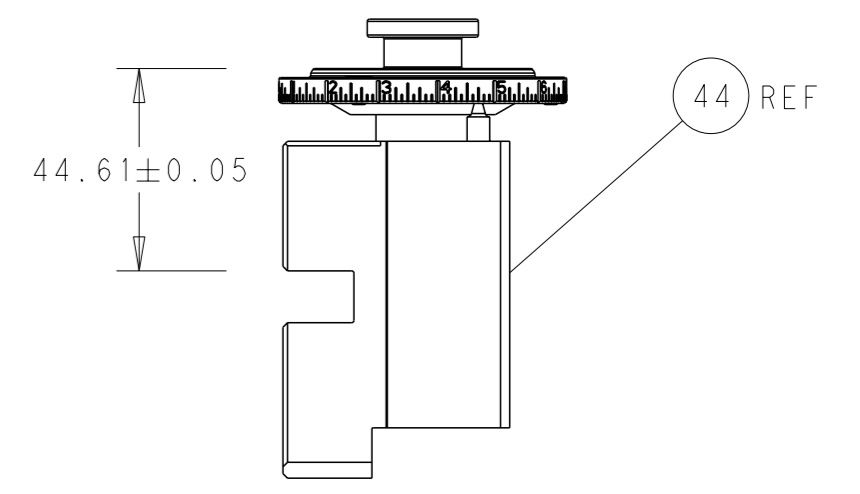

RAM SET-UP

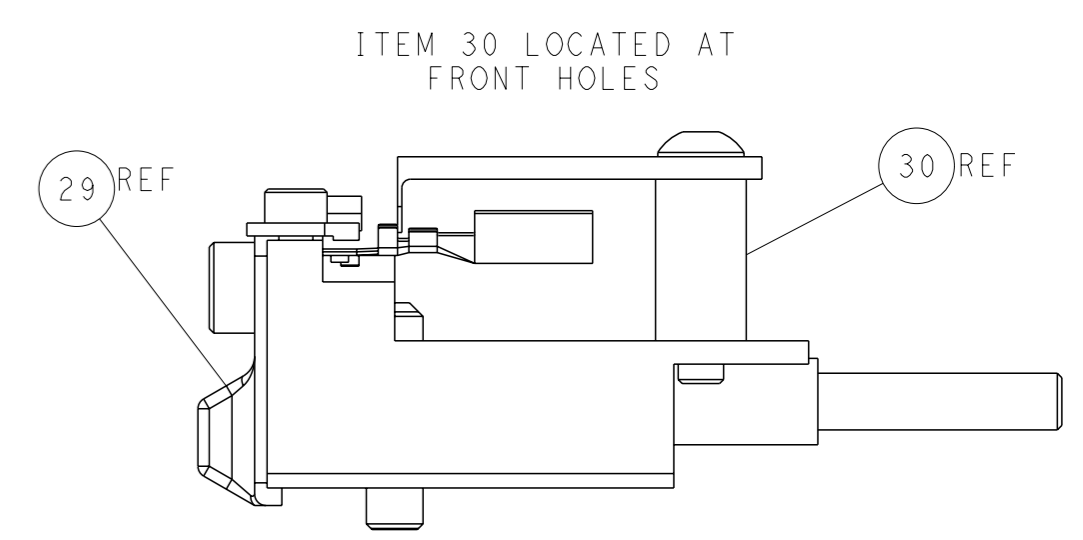

FEED TRACK POSITION GUIDE BY INSULATION BARREL

CAM POSITIONS

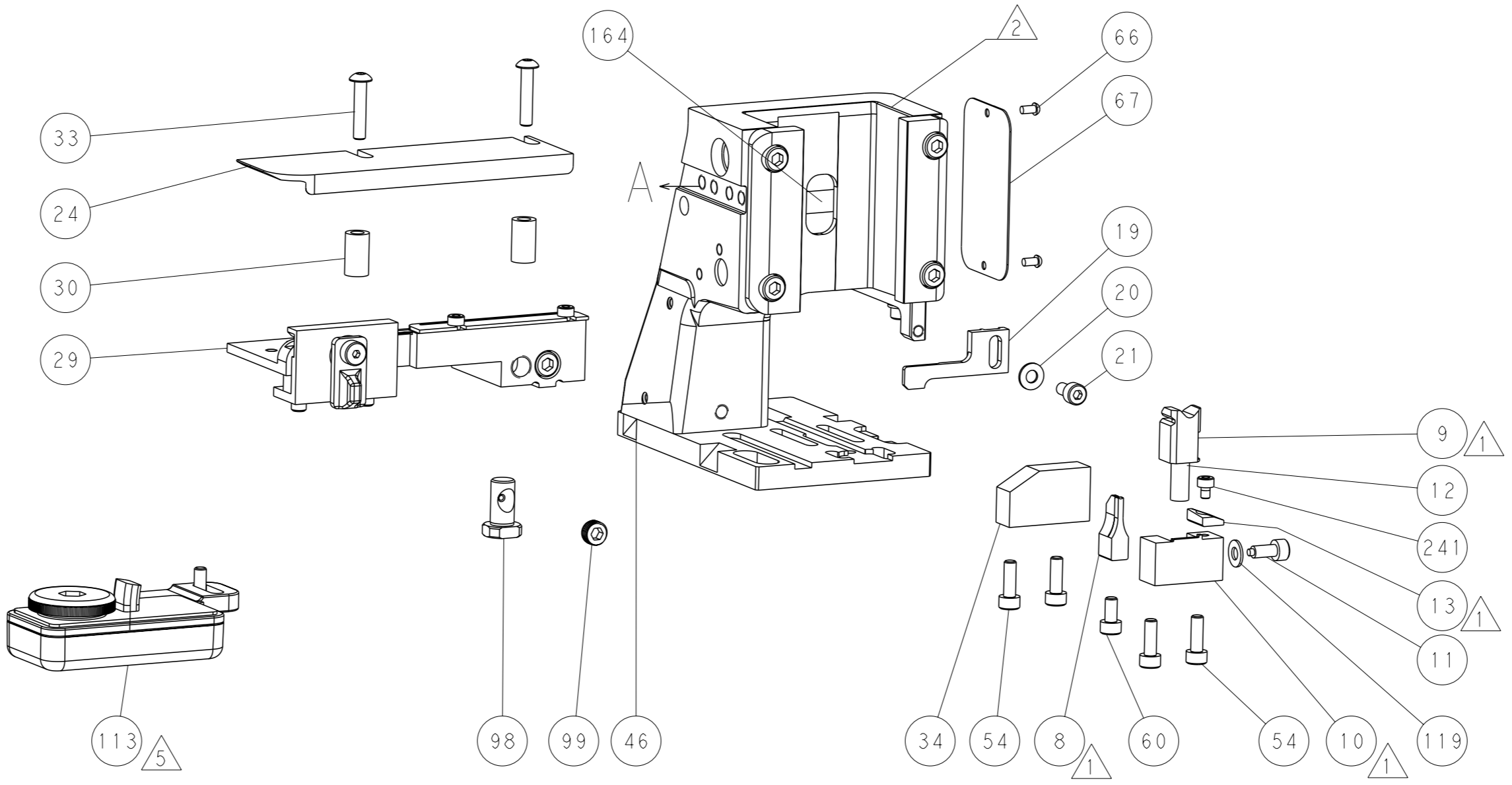
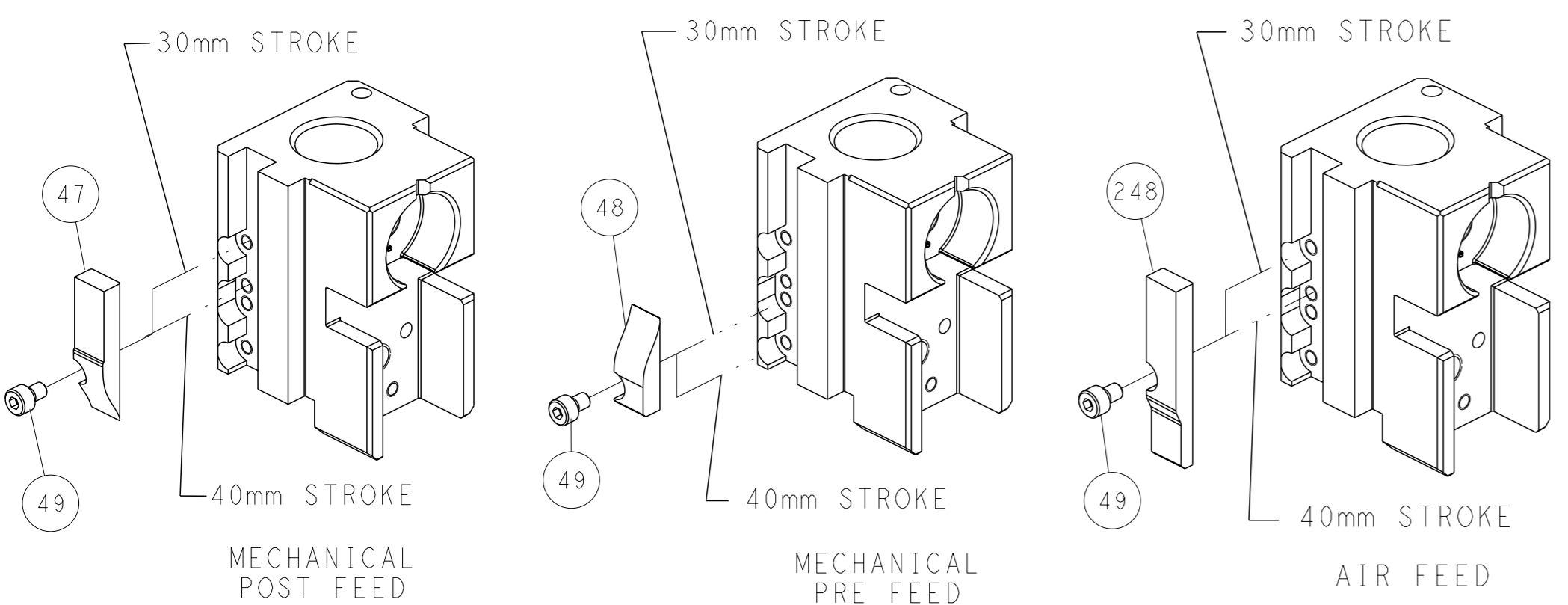

ATLANTIC VERSION
 Shown on sheets 1 of 4 & 2 of 4
 (Pacific version shown on sheets 3 of 4 & 4 of 4)

DIMENSIONS: mm 		TOLERANCES UNLESS OTHERWISE SPECIFIED: 0 PLC ± 1 PLC ± 2 PLC ± 3 PLC ± 4 PLC ± ANGLES ±		OWN: C. CHEN 18MAR2011 CHK: S. XI 18MAR2011 APVD: J. CRUZ 18MAR2011 PRODUCT SPEC APPLICATION SPEC WEIGHT: - CUSTOMER ACCESSIBLE PRODUCTION DRAWING		NAME: Ocean Side Feed Applicator SIZE: A1 CAGE CODE: 00779 DRAWING NO: 2151040 SCALE: 1:2 SHEET: 2 of 4 REV: D	
-----------------------	--	---	--	--	--	--	--

PART NUMBER	REVISION	DESCRIPTION	FEED TYPE
2-2151040-1	D	FINE CRIMP HEIGHT ADJUST	MECHANICAL
2-2151040-2	D	FINE CRIMP HEIGHT ADJUST	PNEUMATIC
7-2151040-7	B	CRIMP TOOLING KIT	-

PACIFIC VERSION TERMINATOR
 INTERFACE ADAPTER

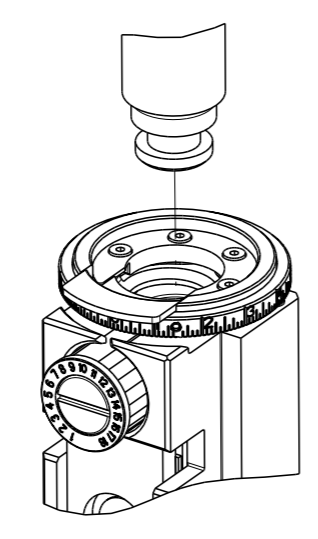

APPLICATOR DATA		
CRIMP	SIZE	TYPE
WIRE	1.40 mm [.055]	F
INSUL	2.03 mm [.080]	O
APPLICATOR INSTRUCTIONS 408-35042		

TERMINAL DATA: TE TERMINAL		TE CRIMP SPECIFICATION	
TERMINAL NAME: AMP MCP 2.8K FLAT TYPE RECEPTACLE			
WIRE STRIP LENGTH		INSULATION DIAMETER RANGE	
3.10-3.70 mm [.122-.146 IN]		Ø1.10-1.40 mm [.043-.055 IN]	
TERMINAL APPLICATION SPECIFICATION	114-18387		
TERMINALS APPLIED			
TE TERMINAL	TE TERMINAL	TE TERMINAL	TE TERMINAL
1241386-1	1241386-2	1241386-3	

WIRE SIZE	CRIMP HEIGHT mm [INCH]	CRIMP HEIGHT REFERENCE SETTING
0.35mm2	1.03+/-0.03 [.041+/-0.001]	7.2
0.25mm2	0.98+/-0.03 [.039+/-0.001]	7.6
0.22mm2	0.96+/-0.03 [.038+/-0.001]	8.1
0.20mm2	0.96+/-0.03 [.038+/-0.001]	8.1

- RECOMMENDED SPARE PARTS
 - REFER TO SUPPLIED INSTRUCTION SHEET FOR CLEANING, LUBRICATION & STORAGE OF APPLICATOR.
 - APPLY PART NUMBER 2-23419-6 LOCTITE TO THREADS OF ITEM 242.
 - CRIMP HEIGHT REFERENCE SETTING WAS THE SETTING USED WHEN THE APPLICATOR WAS QUALIFIED AT THE FACTORY. ADJUSTMENT MAY BE NECESSARY WHEN RUNNING APPLICATOR IN THE FIELD.
 - TERMINAL LUBRICANT IS RECOMMENDED.
6. UNLESS SPECIFIED OTHERWISE TORQUE VALUES SHALL BE USED PER DOCUMENT 101-35000.

***WARNING**
 ON INSTALLATION, SET WIRE DISC TO CRIMP HEIGHT REFERENCE SETTING FOR LARGEST WIRE SIZE. CRIMP HEIGHT REFERENCE SETTINGS GREATER THAN THE VALUE SHOWN MAY CAUSE DAMAGE TO THE CRIMP TOOLING, REFER TO THE INSTRUCTION SHEET FOR PROPER SETUP AND ADJUSTMENTS.

PACIFIC VERSION
 Shown on sheets 3 of 4 & 4 of 4
 (Atlantic version shown on sheets 1 of 4 & 2 of 4)

LOC	DIST	REVISIONS					
A	66	P	LYR	DESCRIPTION	DATE	OWN	APVD
		-		SEE SHEET 1			

-	1	-	2119640-1	PUSH ROD, AIR FEED			250
-	1	-	1803259-1	BUSHING, FLANGED			249
-	1	1	2119082-9	CAM, SNAIL, INSULATION ADJUSTMENT			244
-	1	1	2079764-1	WASHER, WAVE SPRING, CREST-TO-CREST			243
-	1	1	2119083-1	RETAINER, INSULATION DIAL			242
-	1	1	7-18023-7	SCR, SKT HD CAP M3 X 4.0			241
-	-	1	2119580-1	MECHANICAL FEED ASSEMBLY			239
-	1	-	2063440-1	AIR FEED MODULE			238
-	2	-	21045-3	RING, RETAIN, EXTERN, 3/16 CRESCENT			172
-	REF	REF	994970-2	COUNTER, MAGNETIC			164
-	1	-	240638-1	SPRING, FEED FINGER			163
-	1	-	2119641-2	FEED CAM, AIR FEED			151
-	1	1	2168083-8	SCR, SKT HD CAP, RoHS, M4 X 16			144
-	4	4	2168083-9	SCR, SKT HD CAP, RoHS, M4 X 20			143
-	-	1	2119653-2	FEED CAM, POST FEED			142
-	1	1	1-1803583-0	APPLICATOR BASIC ASSEMBLY, SF			141
-	1	1	1803516-1	RAM ASSEMBLY, SF PACIFIC			140
-	1	-	3-23627-7	PIN, RETAIN, GRVD, 3/16 X .854			137
-	1	-	2119799-1	HOLDER, FEED FINGER, AF			136
-	1	1	1-18028-2	WASHER, FLAT, REG M4			119
-	1	1	2119955-1	ASSY, LUBRICATOR, SIDE FEED			113
-	1	1	2844908-1	SCREW, LOCKING			99
-	1	1	2844907-1	POST, LOCKING			98
-	1	1	455888-5	SPACER, CRIMPER			82
-	1	1	1803607-1	DOCUMENTATION PACKAGE			71
-	1	1	2119740-1	TAG, IDENTIFICATION			67
-	2	2	2168078-1	SCREW, DRIVE, RH, RoHS, 2 x .188			66
-	1	1	5-18022-5	SCR, HEX HD CAP, M4 X 6.0			59
-	1	1	1338685-1	PAWL, FEED			56
-	2	2	2-2168083-5	SCR, SKT HD CAP, RoHS, M4 X 14			53
-	1	1	1803382-2	HOLD DOWN, SPRING LOADED			50
-	1	2	18023-9	SCR, SKT HD CAP M4 X 6.0			49
-	-	1	2119652-1	FEED CAM, PRE FEED			48
-	1	1	1803602-1	SCR, BHSC, RoHS (M8 X 25)			41
-	1	1	1-1752356-7	SUPPORT, TERMINAL			34
-	2	2	2079383-5	SCR, BHSC, RoHS (M4 X 20)			33
-	2	2	2-2844962-6	SPACER, CYLINDRICAL, STRIP GUIDE			30
-	1	1	2844992-2	ASSEMBLY, STRIP GUIDE			29
-	1	1	1-455888-0	SPACER, CRIMPER			28
-	1	1	1320928-2	STRIP GUIDE			24
-	1	1	2168083-2	SCR, SKT HD CAP, RoHS, M4 X 8.0			21
-	1	1	1-18028-2	WASHER, FLAT, REG M4			20
-	1	1	2119533-1	STRIPPER, SIDE FEED			19
-	1	1	2119806-1	INSERT, SHEAR			13
-	1	1	3-22280-3	SPRING, COMPRESSION			12
-	1	1	1-356885-4	STOP, SHEAR			11
-	1	1	2119805-1	SHEAR HOLDER, FRONT			10
-	1	1	1803095-6	FLOATING SHEAR, FRONT			9
-	1	1	2-1333201-4	ANVIL, COMBINATION			8
-	1	1	2119757-8	DEPRESSOR, SHEAR			5
-	1	1	1-238011-0	BLOCK, CRIMPER SPACER			4
-	1	1	2119784-3	CRIMPER, INSULATION O PREMIUM			3
-	1	1	455888-3	SPACER, CRIMPER			2
-	1	1	456402-1	CRIMPER, WIRE PREMIUM			1
-77	-22	-21	PART NO	DESCRIPTION			ITEM NO

DIMENSIONS: mm 		TOLERANCES UNLESS OTHERWISE SPECIFIED: 0 PLC ± 1 PLC ± 2 PLC ± 3 PLC ± 4 PLC ± ANGLES ± FINISH ±		DWN C. CHEN 18MAR2011 CHK S. XI 18MAR2011 APVD J. CRUZ 18MAR2011	NAME Ocean Side Feed Applicator
MATERIAL		WEIGHT		SIZE CAGE CODE DRAWING NO A1 00779 C=2151040	RESTRICTED TO CUSTOMER ACCESSIBLE PRODUCTION DRAWING SCALE 1:2 SHEET 3 OF 4 REV D

LOC		DIST		REVISIONS			
A	66	P	LYR	DESCRIPTION	DATE	OWN	APVD
		-		SEE SHEET 1	-	-	-

FEED TYPE MECHANICAL

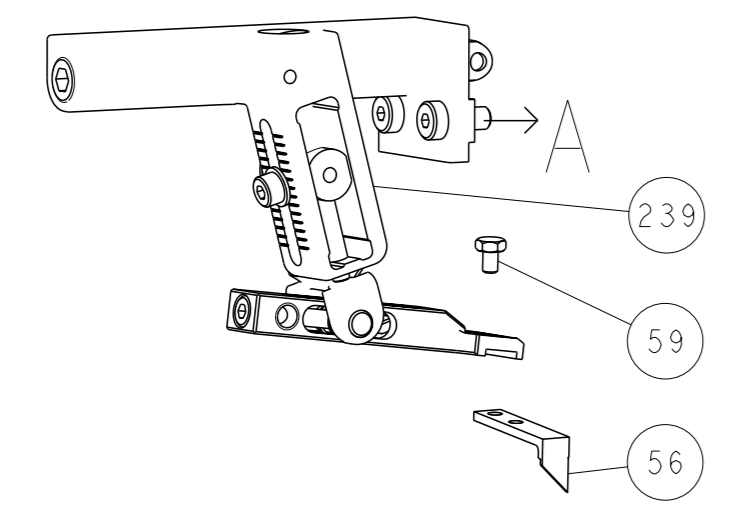

PNEUMATIC

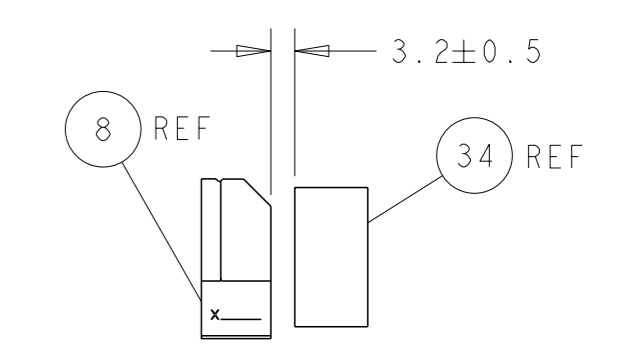
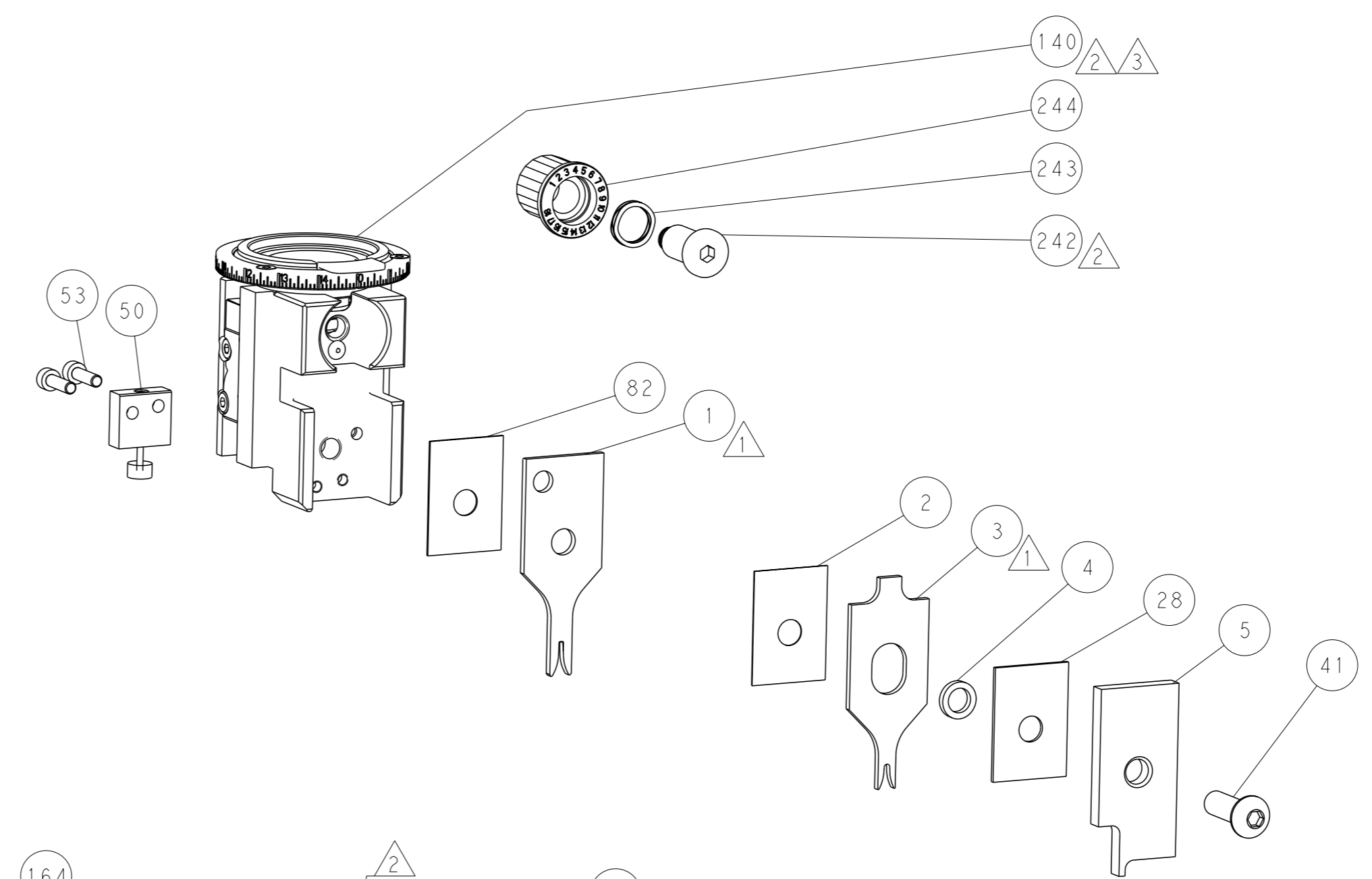
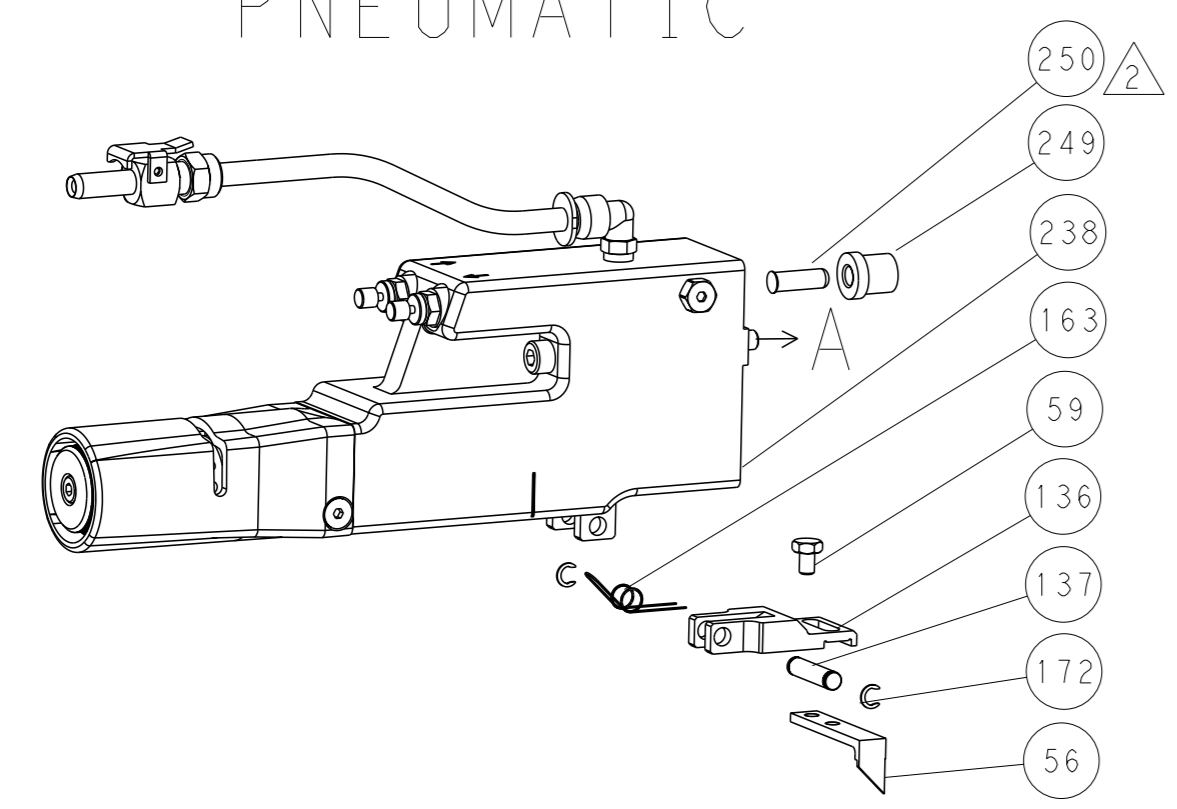

TERMINAL SUPPORT LOCATION

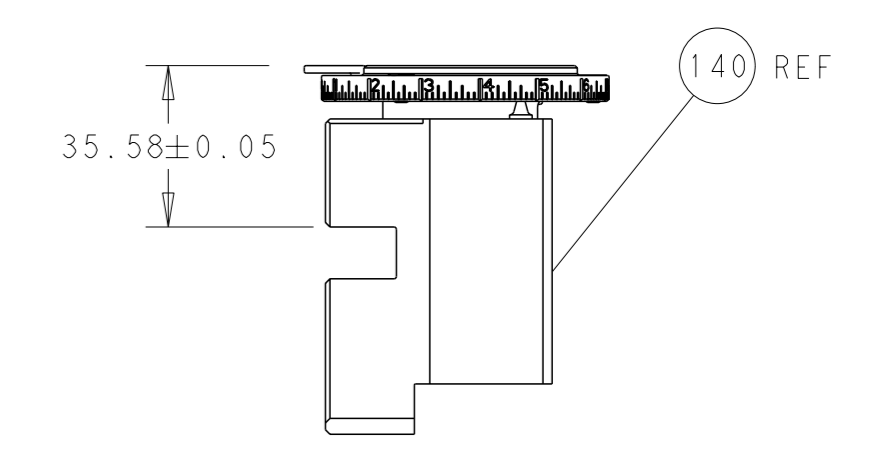
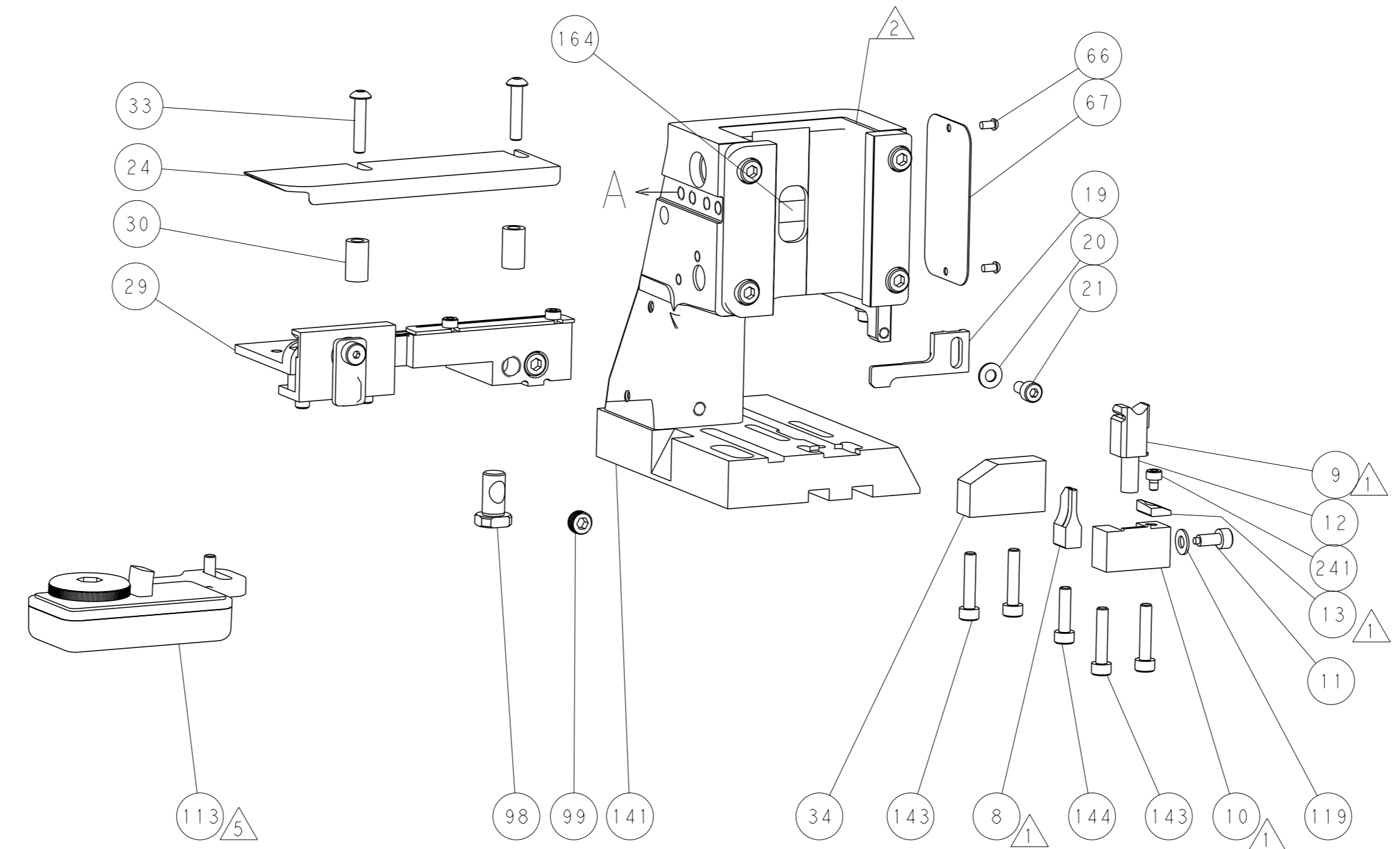

RAM SET-UP

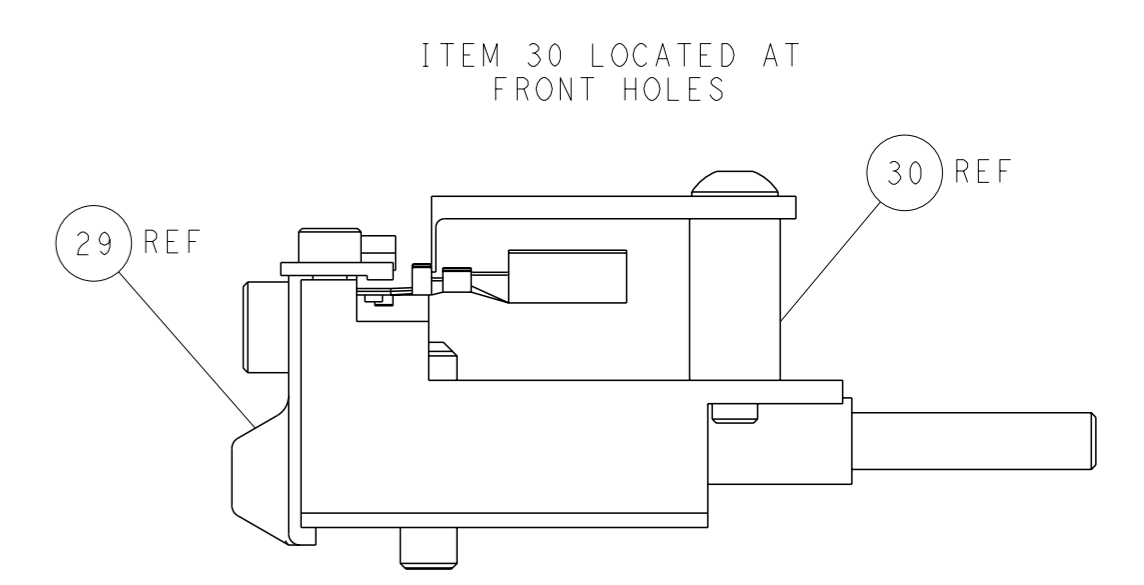

FEED TRACK POSITION
GUIDE BY INSULATION BARREL

CAM POSITIONS

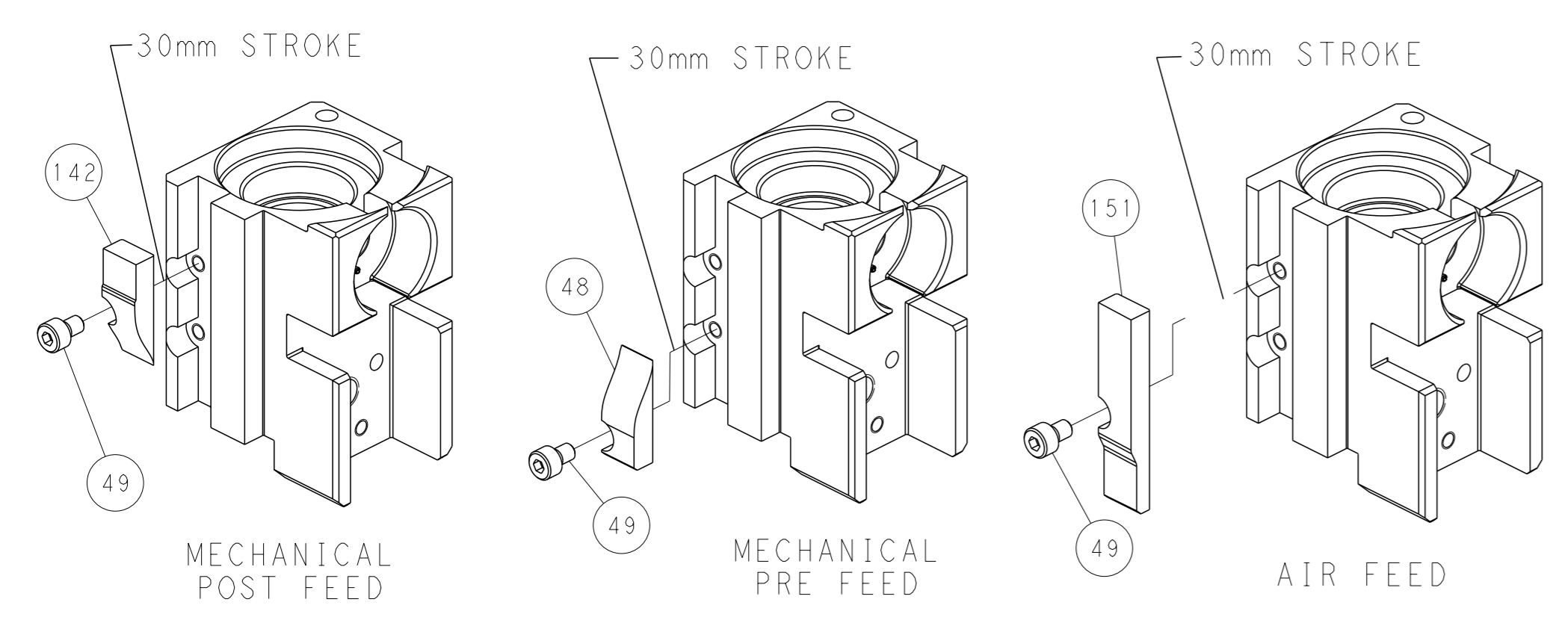

PACIFIC VERSION
 Shown on sheets 3 of 4 & 4 of 4
 (Atlantic version shown on sheets 1 of 4 & 2 of 4)

<small>THIS DRAWING IS A CONTROLLED DOCUMENT FOR TYCO ELECTRONICS CORPORATION. IT IS SUBJECT TO CHANGE AND THE CONTROL AND RESTRICTION DESIGNATION SHOULD BE CONTACTED FOR THE LATEST REVISION.</small>		DWN: C. CHEN 18MAR2011 CHK: S. XI 18MAR2011 APVD: J. CRUZ 18MAR2011	TE Connectivity Harrisburg, PA 17105-3608
DIMENSIONS: mm 	TOLERANCES UNLESS OTHERWISE SPECIFIED: 0 PLC ± 1 PLC ± 2 PLC ± 3 PLC ± 4 PLC ± ANGLES ± FINISH ±	NAME: Ocean Side Feed Applicator SIZE: A1 CAGE CODE: 00779 DRAWING NO: C=2151040	RESTRICTED TO: D SCALE: 1:2 SHEET: 4 of 4 REV: D
MATERIAL:		WEIGHT:	
CUSTOMER ACCESSIBLE PRODUCTION DRAWING			