

MATERIAL AND FINISHES

BODY: STAINLESS STEEL  
PASSIVATED

CONTACT: BRASS  
PLATED GOLD

INSULATOR: TEFLON

COUPLING NUT: BRASS  
PLATED NICKEL

SNAP RING: BERYLLIUM COPPER

GASKET: SILICONE RUBBER

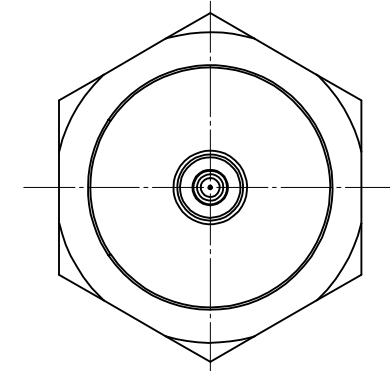
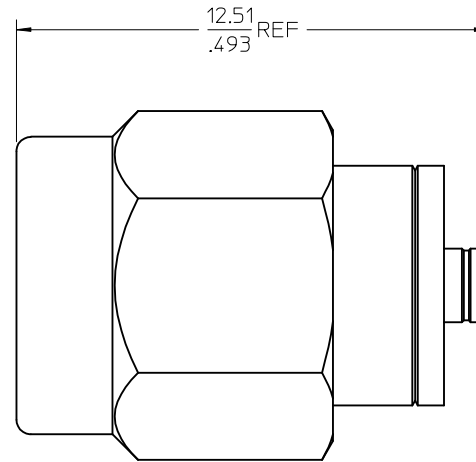
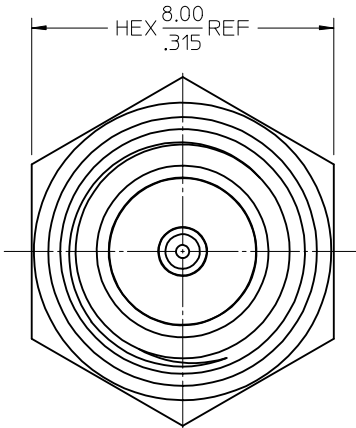
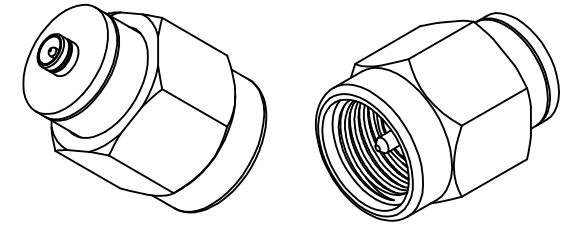

73386-0851	73386-0850 ONE PIECE PER BAG
73386-0850	TRAY
PART NO.	PACKAGING

CHG: UPDATED TITLE & PACKAGING PER RF15-E332 EC NO: URF2016-0227 DRWR:YEH 2015/09/21 CHKD: APPR:YCHENG 2015/09/24 REV:	QUALITY SYMBOLS	GENERAL TOLERANCES (UNLESS SPECIFIED)	DIMENSION STYLE	SCALE	DESIGN UNITS	THIRD ANGLE PROJECTION
	▽=0	mm INCH	MM/IN	10:1	METRIC	
	▽=0	4 PLACES ± --- ± ---	DRAWN BY DATE	TITLE		
	▽=0	3 PLACES ± --- ± ---	JOHN 2004/05/28	BSA SMA PLUG TO MCRF PLUG 50 OHMS BSA-SMAP/MCRFP		
	2 PLACES ± 0.10 ± ---	CHECKED BY DATE	molex			
	1 PLACE ± 0.13 ± ---	KENNY 2004/05/28	DOCUMENT NO. SD-73386-085			
	0 PLACE ± ±	APPROVED BY DATE	SHEET NO. 1 OF 1			
	ANGULAR ± 2 °	MISEN 2004/05/28	THIS DRAWING CONTAINS INFORMATION THAT IS PROPRIETARY TO MOLEX INCORPORATED AND SHOULD NOT BE USED WITHOUT WRITTEN PERMISSION			
	DRAFT WHERE APPLICABLE MUST REMAIN WITHIN DIMENSIONS	MATERIAL NO.				
		SIZE C				

MATERIAL AND FINISHES

BODY: STAINLESS STEEL  
PASSIVATED

CONTACT: BRASS  
PLATED GOLD

INSULATOR: TEFLON

COUPLING NUT: BRASS  
PLATED NICKEL

SNAP RING: BERYLLIUM COPPER

GASKET: SILICONE RUBBER

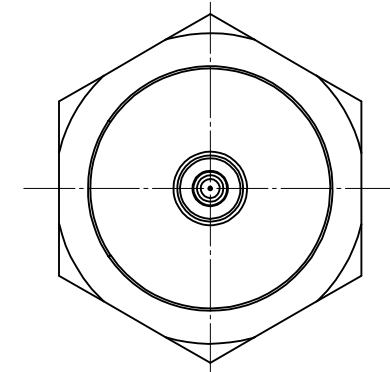
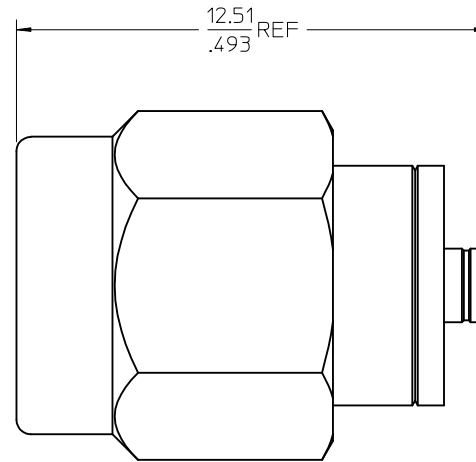
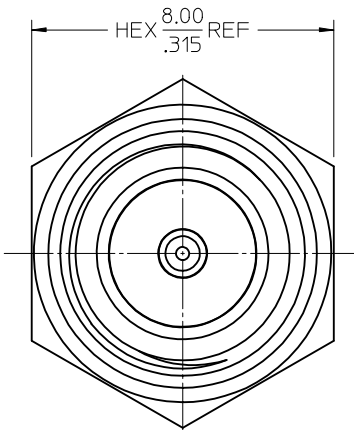
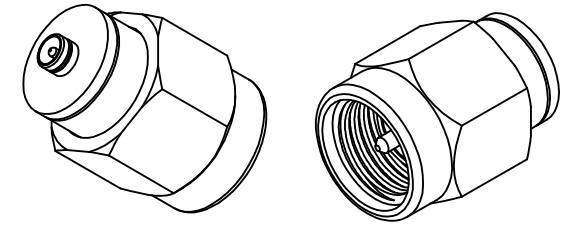

73386-0851	73386-0850 ONE PIECE PER BAG
73386-0850	TRAY
PART NO.	PACKAGING

CHG: UPDATED TITLE & PACKAGING PER RF15-E332 EC NO: URF2016-0227 DRWR:YEH 2015/09/21 CHKD: APPR:YCHENG 2015/09/24	QUALITY SYMBOLS	GENERAL TOLERANCES (UNLESS SPECIFIED)	DIMENSION STYLE	SCALE	DESIGN UNITS	THIRD ANGLE PROJECTION
	▽=0	mm INCH	MM/IN	10:1	METRIC	
	▽=0	4 PLACES ± --- ± ---	DRAWN BY DATE	TITLE		
	▽=0	3 PLACES ± --- ± ---	CHECKED BY DATE	BSA SMA PLUG TO MCRF PLUG 50 OHMS BSA-SMAP/MCRFP		
		2 PLACES ± 0.10 ± ---	APPROVED BY DATE	molex		
		1 PLACE ± 0.13 ± ---	MISEN 2004/05/28	DOCUMENT NO. SD-73386-085		
		0 PLACE ± ±	MATERIAL NO.	SHEET NO. 1 OF 1		
		ANGULAR ± 2 °	SEE TABLE			
		DRAFT WHERE APPLICABLE MUST REMAIN WITHIN DIMENSIONS	THIS DRAWING CONTAINS INFORMATION THAT IS PROPRIETARY TO MOLEX INCORPORATED AND SHOULD NOT BE USED WITHOUT WRITTEN PERMISSION			