



TAI-SAW TECHNOLOGY CO., LTD.

No. 3, Industrial 2nd Rd., Ping-Chen Industrial District,
Taoyuan, 324, Taiwan, R.O.C.

TEL: 886-3-4690038 FAX: 886-3-4697532

E-mail: tstsales@mail.taisaw.com Web: www.taisaw.com

Product Specifications Approval Sheet

Product Description: Crystal Unit 2.0x1.2 Tuning Fork 32.768KHz

TST Part No.: TZ3158D

Customer Part No.: _____

| |
|-----------------------------|
| Customer signature required |
| Company: _____ |
| Division: _____ |
| Approved by : _____ |
| Date: _____ |

Checked by: _____ Yifan Chen *Yifan*

Approved by: _____ Kelly Huang *Kelly Huang*

Date: _____ 12/15/2022

1. Customer signed back is required before TST can proceed with sample build and receive orders.
2. Orders received without customer signed back will be regarded as agreement on the specifications.
3. Any specifications changes must be approved upon by both parties and a new revision of specifications shall be released to reflect the changes.



TAI-SAW TECHNOLOGY CO., LTD.
Tuning Fork 2.0x1.2 32.768KHz Crystal Unit

MODEL NO.: TZ3158D

REV. NO.: 1.0

Revise:

| Rev. | Rev. Page | Rev. Account | Date | Ref. No. | Reviser |
|------|-----------|-----------------|-----------|----------|------------|
| 1 | N/A | Initial release | 12/15/22' | N/A | Yifan Chen |



TAI-SAW TECHNOLOGY CO., LTD.

No. 3, Industrial 2nd Rd., Ping-Chen Industrial District,
Taoyuan, 324, Taiwan, R.O.C.

TEL: 886-3-4690038 FAX: 886-3-4697532

E-mail: tstsales@mail.taisaw.com Web: www.taisaw.com

Tuning Fork 2.0x1.2 32.768KHz Crystal Unit

MODEL NO.: TZ3158D

REV. NO.: 1.0

Features:

- Ceramic Seam Weld Package
- Excellent Reliability Performance
- Ultra Miniature Package
- Available to Surface Mount Technology and IR Reflow Process
- Moisture Sensitivity Level (MSL) : Level-1

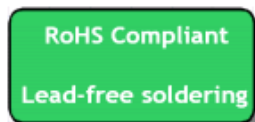

Description and Applications:

Surface mount 2.0mmx1.2mm crystal unit for use in communications devices,.

Electrical Specifications:

| TZ3158D | Specification |
|----------------------------------|---|
| Nominal Frequency | 32.768000 KHz |
| Storage Temperature Range | -55°C to +125°C |
| Operating Temperature Range | -40°C to +105°C |
| Turnover Temperature | 25 +/- 5 °C |
| Parabolic Curvature Constant | -0.04 x10 ⁻⁶ /°C ² max. |
| Drive Level | 0.5 uW max. |
| Frequency Make Tolerance (FL) | +/-20 ppm |
| Equivalent Series Resistor (ESR) | 90 kΩ max . |
| Motional Capacitance (C1) | 6.4 fF typ |
| Shunt Capacitance (Co) | 1.3 pF typ |
| Load Capacitance (CL) | 7 pF |
| Aging | +/-3.0 ppm / year |
| Insulation Resistance | 500M Ω min at DC 100V +/-15 |
| Marking | Laser marking |

TST DCC
Release document

Mechanical Dimensions (mm):

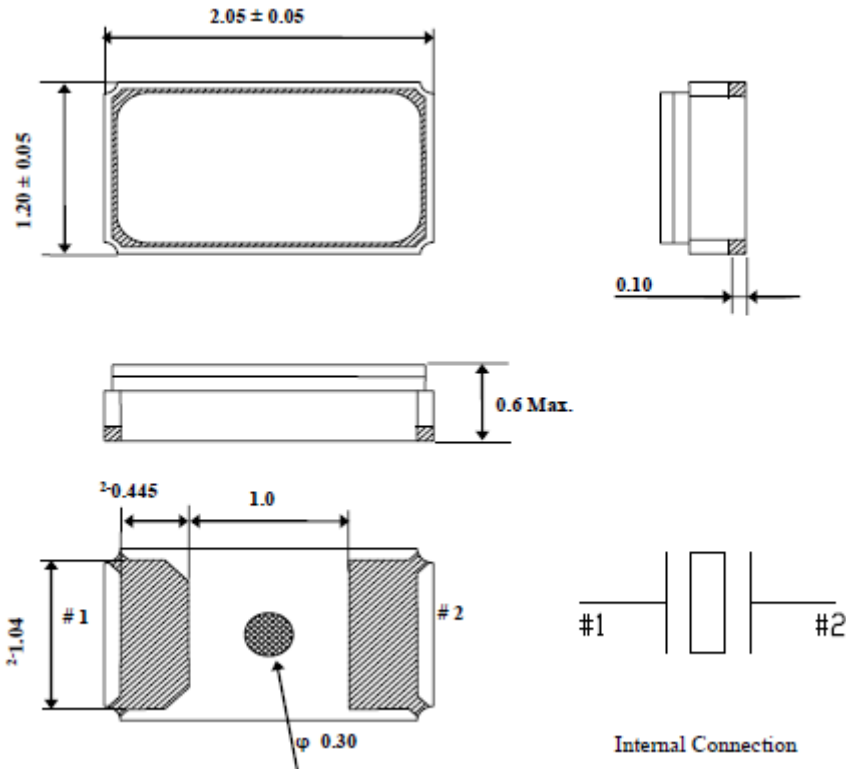

Recommended Land Pattern: (unit: mm)

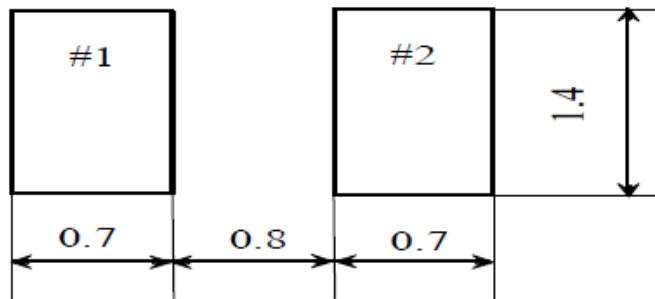

Marking:

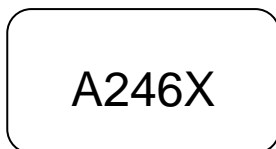

A: Frequency code

2: Year code : 2 for 2022

47: Week code

X: Traceability code

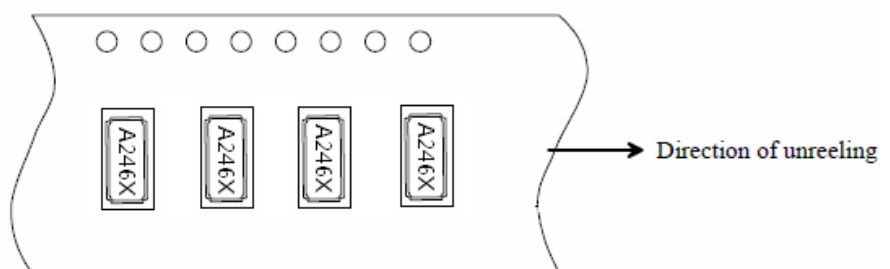

Reel Dimensions (mm):

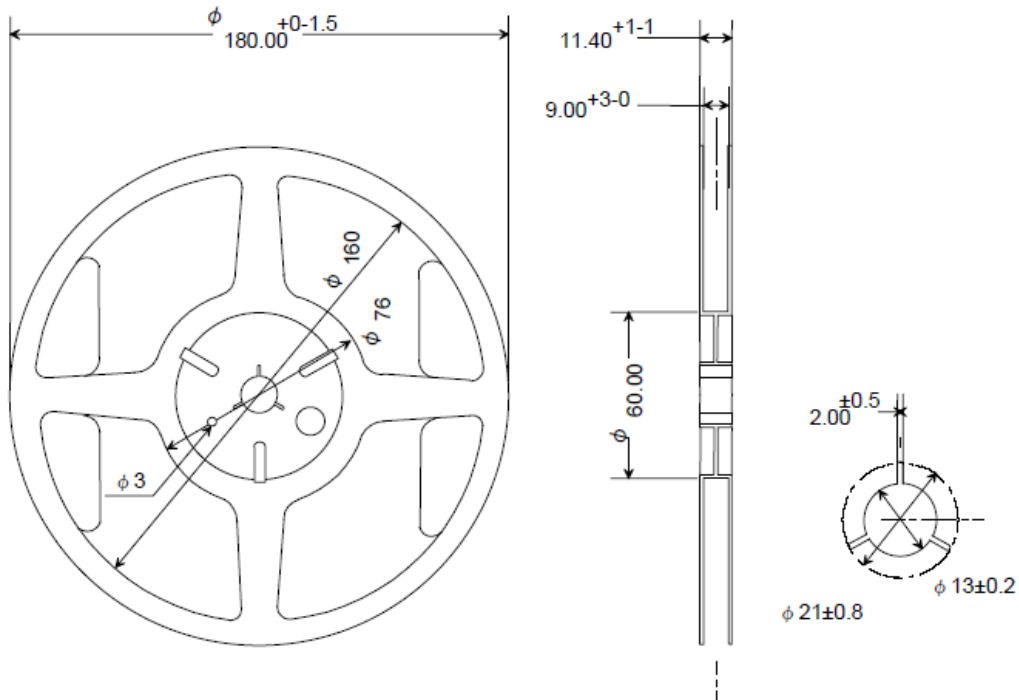

Tape Dimensions (mm):

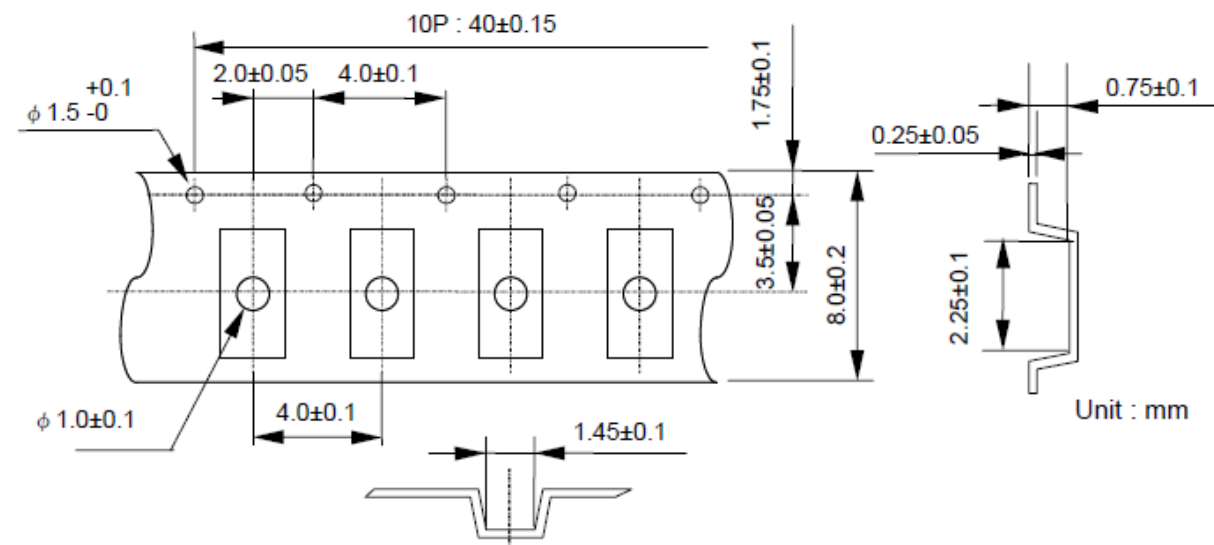

Unit : mm

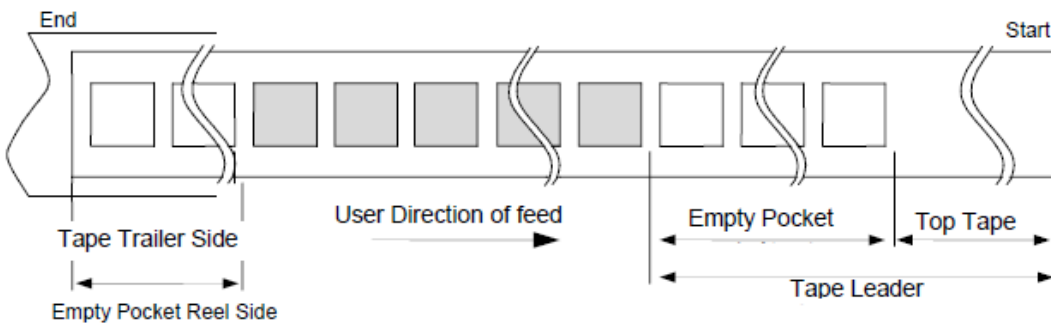

Packing Quantity/Packing:

3000 pcs maximum per reel

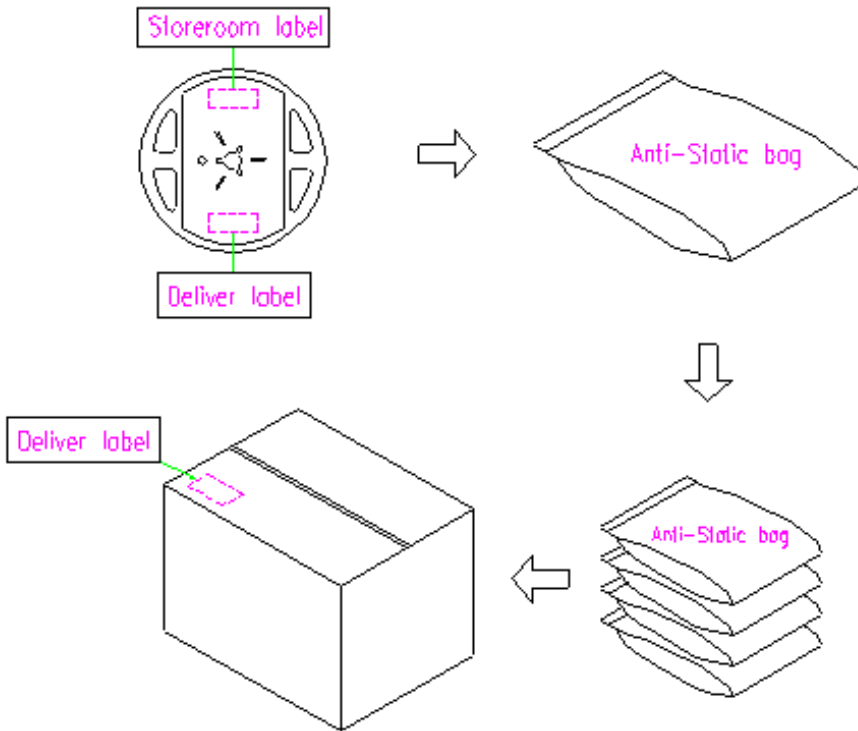

Reflow Profile:

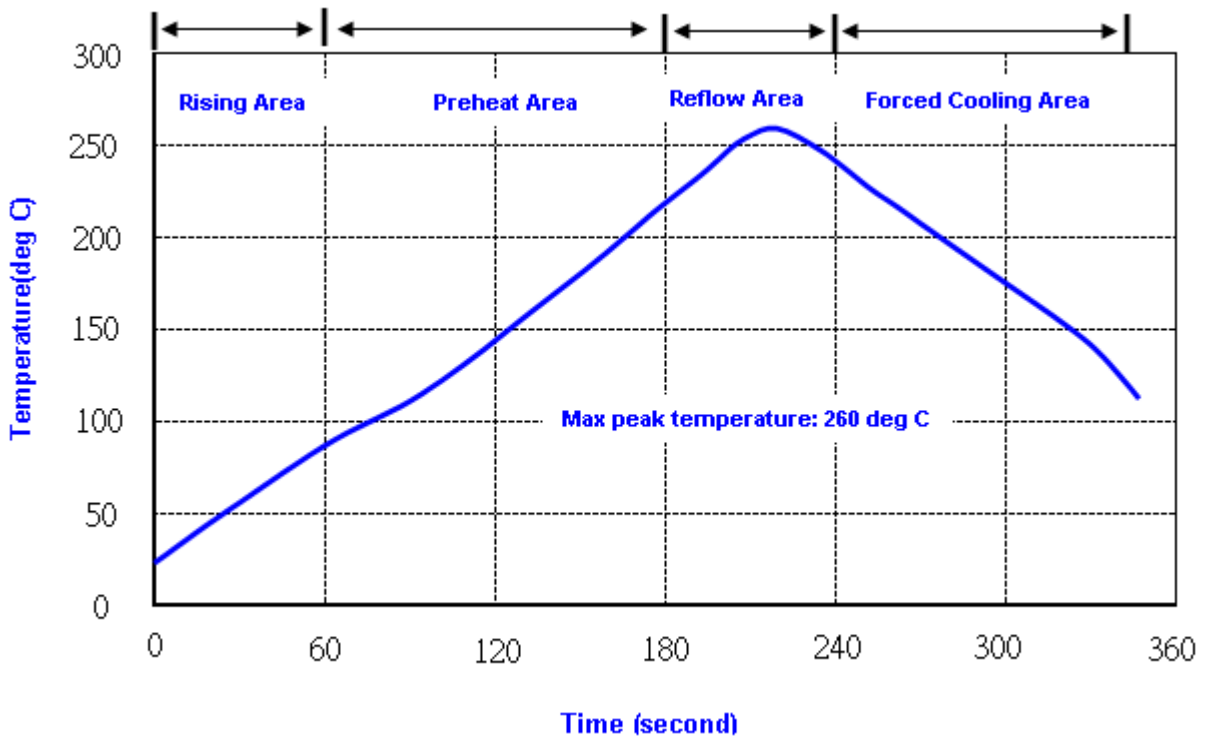

Reliability Specifications

| Test name | Test process / method | Reference standard |
|--|--|-----------------------------------|
| Mechanical characteristics | | |
| resistance to Soldering heat (IR reflow) | Temp/ Duration : 265°C /10sec x2 times Total time : 4min.(IR-reflow) | EIAJED-4701 -300(301)M(II) |
| Vibration | Total peak amplitude : 1.5mm Vibration frequency : 10 to 2000 Hz Sweep period : 20 minute Vibration directions : 3 mutually perpendicular Duration : 2 hr / direc. | MIL-STD 202G method 204 |
| Mechanical Shock | directions : 3 impacts per axis Acceleration : 3000g's, +20/-0 % Duration : 0.3 ms (total 18 shocks) Waveform : Half-sine | MIL-STD 202G method 213 |
| Solderability | Solder Temperature:265±5°C Duration time: 5±0.5 seconds. | J-STD-002 |
| Environmental characteristics | | |
| Thermal Shock | Heat cycle conditions -40 °C (30min) ↔ 85 °C (30min) * cycle time : 10 times | MIL-STD 883G method 1010.8 |
| Humidity test | Temperature : 85 ± 2 °C Relative humidity : 85% Duration : 96 hours | MIL-STD 202G method 103 |
| Dry heat (Aging test) | Temperature : 125 ± 2 °C Duration : 168 hours | MIL-STD 202G method 108A |
| Cold resistance (Low Temp Storage) | Temperature : -40 ± 2 °C Duration : 96 hours | IEC 60068-2-1 |