

REVISIONS					
P	LTR	DESCRIPTION	DATE	OWN	APPRO
U	REV PER ECO	17-010391	8-8-17	CT	DM

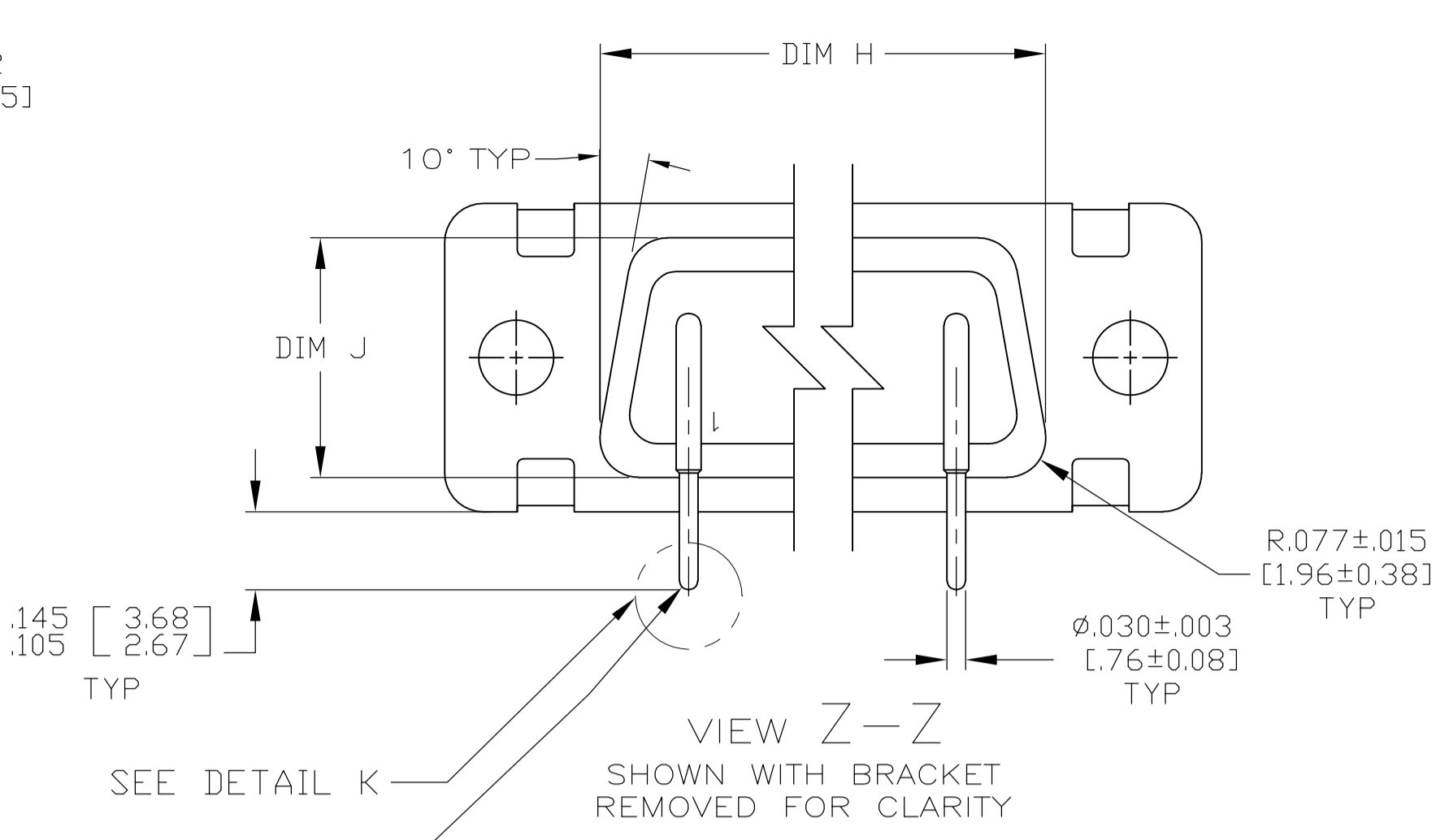

- 1 SEE SHEET 2 FOR RECOMMENDED P.C. BOARD LAYOUT. TRUE POSITION TOLERANCE FOR P.C. BOARD LAYOUT IS .010 [0.25] AT MAX MATERIAL CONDITION. SUGGESTED BOARD THICKNESS IS .062 [1.57]
- 2 THE CONNECTORS DESCRIBED IN THIS DOCUMENT MEET THE REQUIREMENTS OF MIL-DTL-24308 AND MATE WITH ANY RECEPTACLE CONNECTOR WITH SAME INSERT ARRANGEMENT.
- 3 MARKED WITH .047 [1.19]-.062 [1.57] HIGH CHARACTERS. FAR SIDE REFERS TO THE WIDE SIDE OF THE KEYSTONE. NEAR SIDE REFERS TO THE NARROW SIDE OF THE KEYSTONE. IF THE SHELL IS TOO SMALL FOR THE ENTIRE MARKING MARKING SHALL BE SPLIT AS FOLLOWS:
 - A. "MFG'S" (NAME, BRAND OR LOGO), AND DATE CODE ON FRONT SHELL, NEAR SIDE.
 - B. "MFG'S" PART NUMBER ON REAR SHELL, NEAR SIDE.
- 4 SOLDER DIPPED PER J-STD-001, CLASS 3 WITH Sn63 SOLDER PER J-STD-006 IN THIS REGION (LOOSE PIECE).
- 5 SOLDER DIP INSPECTED PRIOR TO ASSEMBLY.

CONTACT (QTY = NO. OF POSN)
 MATL: BRASS PER ASTM-B-16, OR BERYLLIUM COPPER PER ASTM-B-194
 FINISH: GOLD PER ASTM-B-488, .000050 MIN THK
 OVER NICKEL PER QQ-N-290, .00005 MIN THK

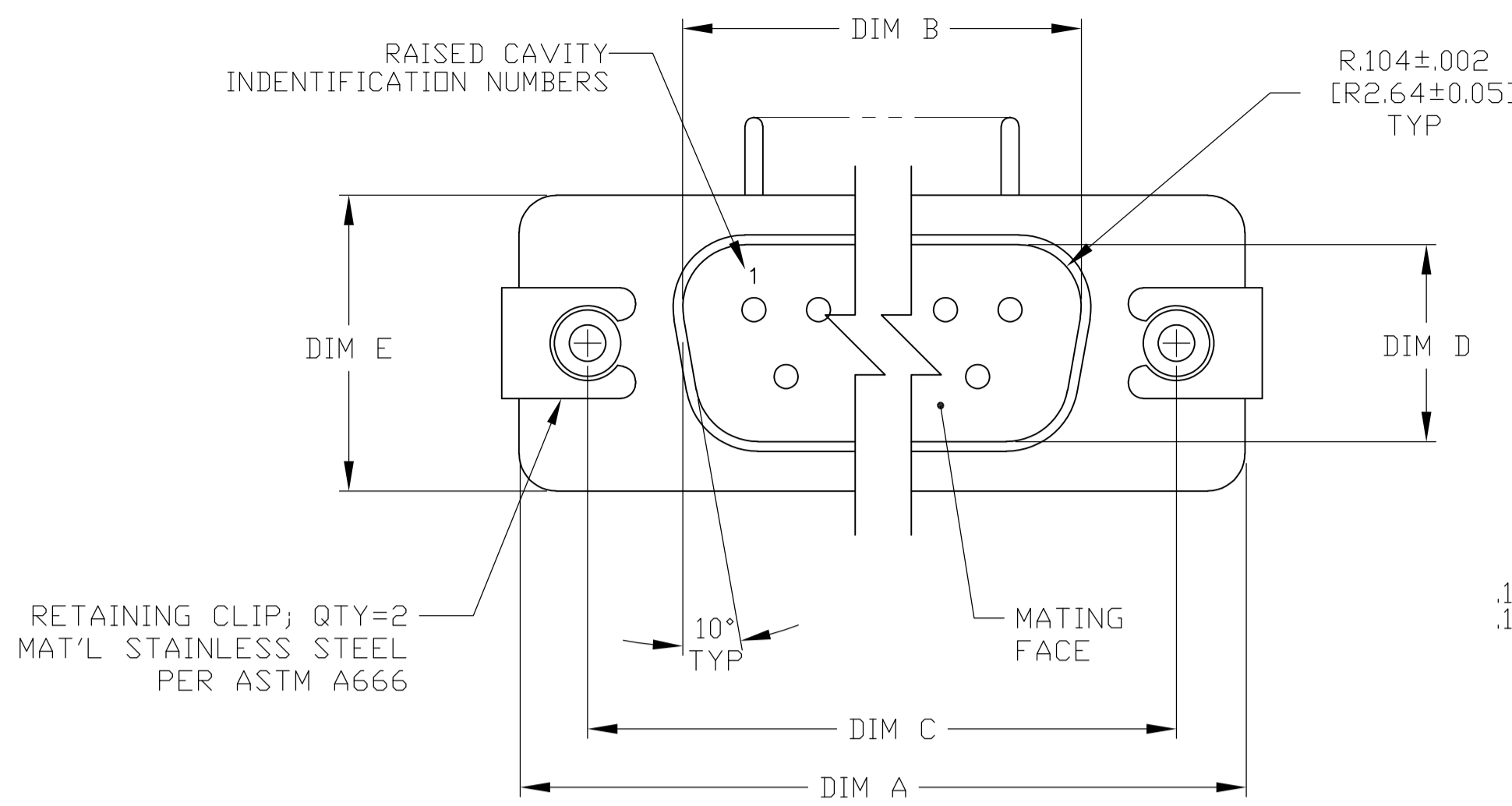
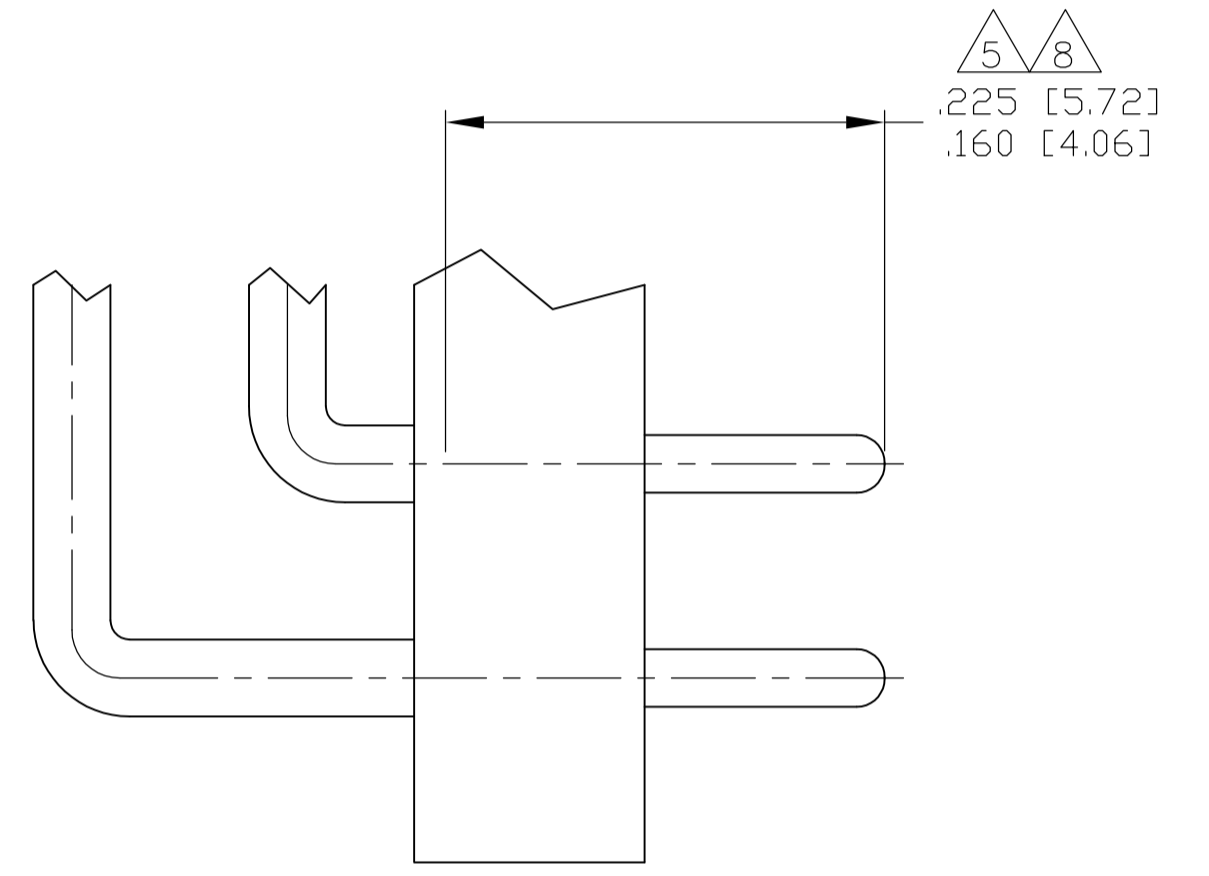
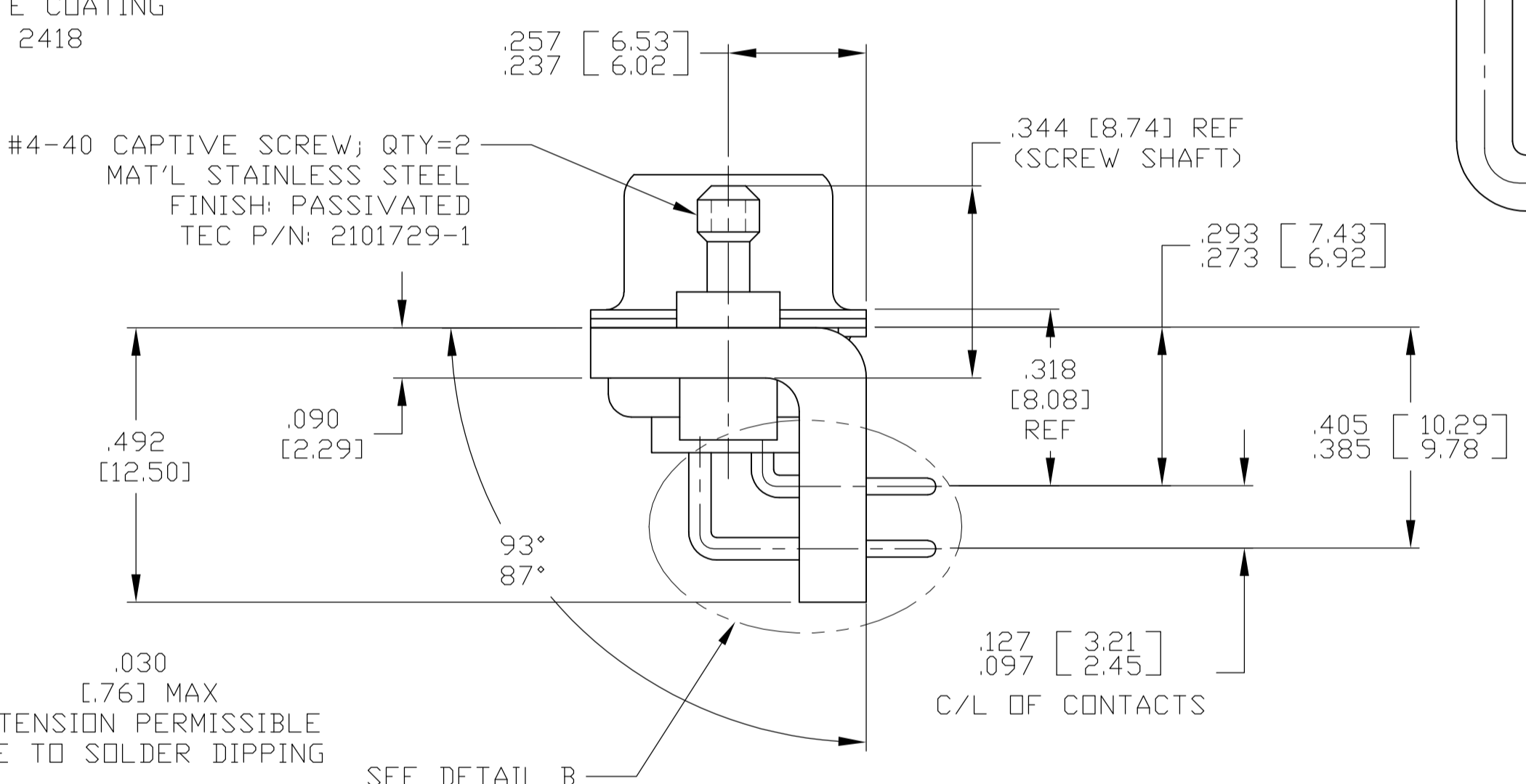
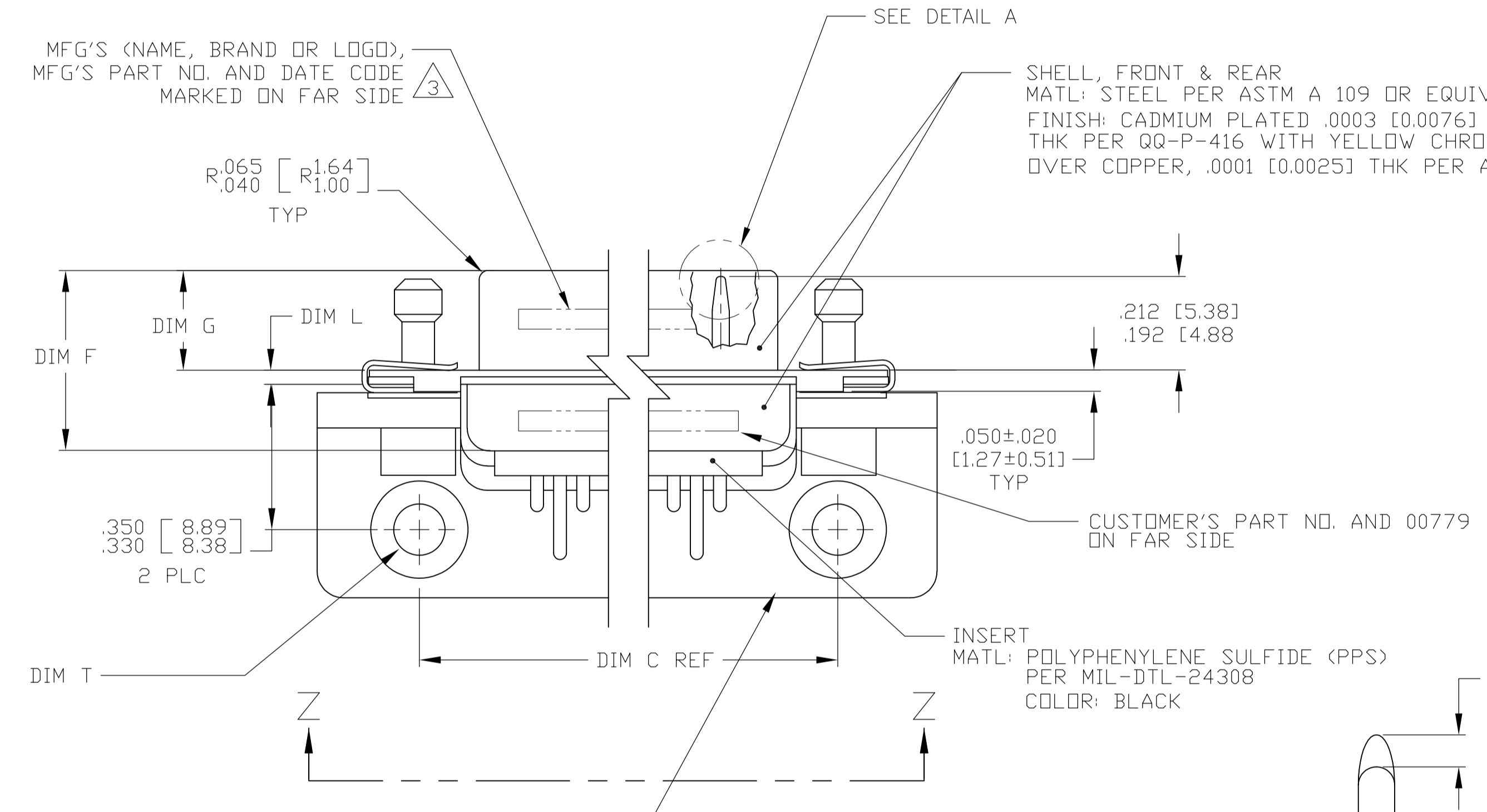

DETAIL B
SCALE 10:1

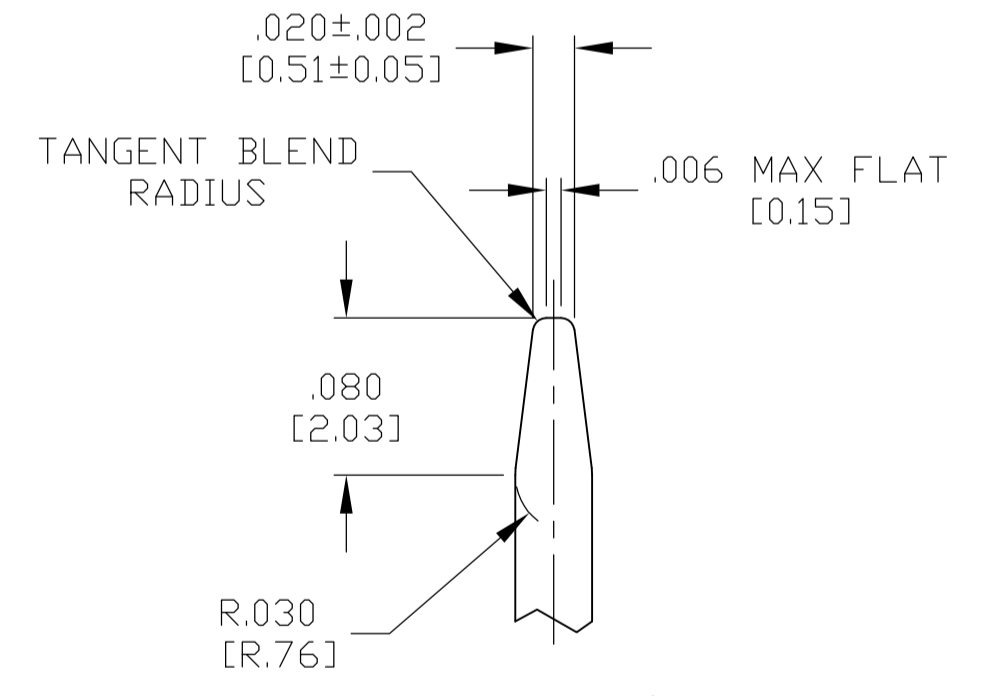

DETAIL A
SCALE 10:1
ALL CONTACTS
1--2, 1--4, 2--2 & 2--4 ONLY

DETAIL K
SCALE 10:1
ALL CONTACTS

SHELL SIZES 1 THRU 4
CONTACT CONFIGURATION

BRACKET
 MAT'L: ULTEM 2300; COLOR: BLACK
 OR ULTEM 2200; COLOR: BLACK
 OR THERMOPLASTIC PER MIL-M-24519 TYPE GPT-30F
 COLOR: BLACK

DIM T	DIM L	DIM J	DIM H	DIM G	DIM F	DIM E	DIM D	DIM C	DIM B	DIM A	INSERT ARRANGEMENT	NO OF POS	SHELL SIZE	CUSTOMER'S P/N MARKED ON CONNECTOR	MFG'S P/N MARKED ON CONNECTOR	MFG'S PART NO.
0.128 ^{+0.005} _{-0.001} [3.25 ^{+0.13} _{-0.03}] (2 PLC)	.049 [1.24]	.432 [10.97]	2.282 [57.96]	.236 [5.99]	.436 [11.07]	.509 [12.93]	.334 [8.48]	2.505 [63.63]	2.187 [54.97]	2.744 [69.70]	MS18276-1	37	4	13604039-1	2-2101619-4	2-2101619-4
Ø.220 [5.59] X .060 [1.52] C-BORE	.029 [0.74]	.412 [10.46]	2.262 [57.45]	.224 [5.69]	.416 [10.57]	.479 [12.17]	.324 [8.23]	2.495 [63.37]	2.177 [54.71]	2.714 [68.94]						
0.128 ^{+0.005} _{-0.001} [3.25 ^{+0.13} _{-0.03}] (2 PLC)	.040 [1.02]	.432 [10.97]	1.093 [27.76]	.238 [6.05]	.432 [10.97]	.509 [12.93]	.334 [8.48]	1.317 [33.45]	.999 [24.79]	1.556 [39.52]	MS18274-1	15	2	13604039-2	2-2101619-2	2-2101619-2
Ø.220 [5.59] X .060 [1.52] C-BORE	.020 [0.51]	.412 [10.46]	1.073 [27.25]	.229 [5.82]	.412 [10.46]	.479 [12.17]	.324 [8.23]	1.307 [33.20]	.989 [24.54]	1.526 [38.76]						
Ø.120 [3.05] (2 PLC)	.049 [1.24]	.432 [10.97]	2.282 [57.96]	.236 [5.99]	.436 [11.07]	.509 [12.93]	.334 [8.48]	2.505 [63.63]	2.187 [54.97]	2.744 [69.70]	MS18276-1	37	4	13603949-1	1-2101619-4	1-2101619-4
Ø.228 [5.80] X 82° C-SINK	.029 [0.74]	.412 [10.46]	2.262 [57.45]	.224 [5.69]	.416 [10.57]	.479 [12.17]	.324 [8.23]	2.495 [63.37]	2.177 [54.71]	2.714 [68.94]						
Ø.120 [3.05] (2 PLC)	.040 [1.02]	.432 [10.97]	1.093 [27.76]	.238 [6.05]	.432 [10.97]	.509 [12.93]	.334 [8.48]	1.317 [33.45]	.999 [24.79]	1.556 [39.52]	MS18274-1	15	2	13603949-2	1-2101619-2	1-2101619-2
Ø.228 [5.80] X 82° C-SINK	.020 [0.51]	.412 [10.46]	1.073 [27.25]	.229 [5.82]	.412 [10.46]	.479 [12.17]	.324 [8.23]	1.307 [33.20]	.989 [24.54]	1.526 [38.76]						
SUPERSEDED BY 1-2101619-4	.049 [1.24]	.432 [10.97]	2.282 [57.96]	.236 [5.99]	.436 [11.07]	.509 [12.93]	.334 [8.48]	2.505 [63.63]	2.187 [54.97]	2.744 [69.70]	MS18276-1	37	4		2101619-4	2101619-4
SUPERSEDED BY 1-2101619-2	.029 [0.74]	.412 [10.46]	2.262 [57.45]	.224 [5.69]	.416 [10.57]	.479 [12.17]	.324 [8.23]	2.495 [63.37]	2.177 [54.71]	2.714 [68.94]						
	.040 [1.02]	.432 [10.97]	1.093 [27.76]	.238 [6.05]	.432 [10.97]	.509 [12.93]	.334 [8.48]	1.317 [33.45]	.999 [24.79]	1.556 [39.52]	MS18274-1	15	2		2101619-2	2101619-2
	.020 [0.51]	.412 [10.46]	1.073 [27.25]	.229 [5.82]	.412 [10.46]	.479 [12.17]	.324 [8.23]	1.307 [33.20]	.989 [24.54]	1.526 [38.76]						

THIS DRAWING IS A CONTROLLED DOCUMENT. DIMENSIONING AND TOLERANCING PER ASME Y14.5M (ISO STANDARDS). DIMENSIONS: INCHES [mm]. TOLERANCES UNLESS OTHERWISE SPECIFIED: 0 PLC ± .005 [0.13], 1 PLC ± .005 [0.13], 2 PLC ± .005 [0.13], 3 PLC ± .005 [0.13], 4 PLC ± .005 [0.13]. ANGLES: ± 1'.

MATERIAL: SEE CALLOUTS. FINISH: SEE CALLOUTS.

WEIGHT: 0. A1 00779 C=2101619. CUSTOMER DRAWING. SCALE: 4:1. SHEET: 1 OF 2. REV: U.

DIN: C.C.THOMAS 11-4-09. CJK: 11-4-09. RELEASE: 11-4-09. NAME: PLUG ASSEMBLY, AMPLIMITE, RT ANGLE SPECIAL, SERIES 109. APPLICATION SPEC: -. SIZE: A1. CAGE CODE: 00779. DRAWING NO: 2101619. RESTRICTED TO: -. CUSTOMER DRAWING. SCALE: 4:1. SHEET: 1 OF 2. REV: U.

REVISIONS				
P	LTR	DESCRIPTION	DATE	APP'D
-		SEE SHEET 1	-	-

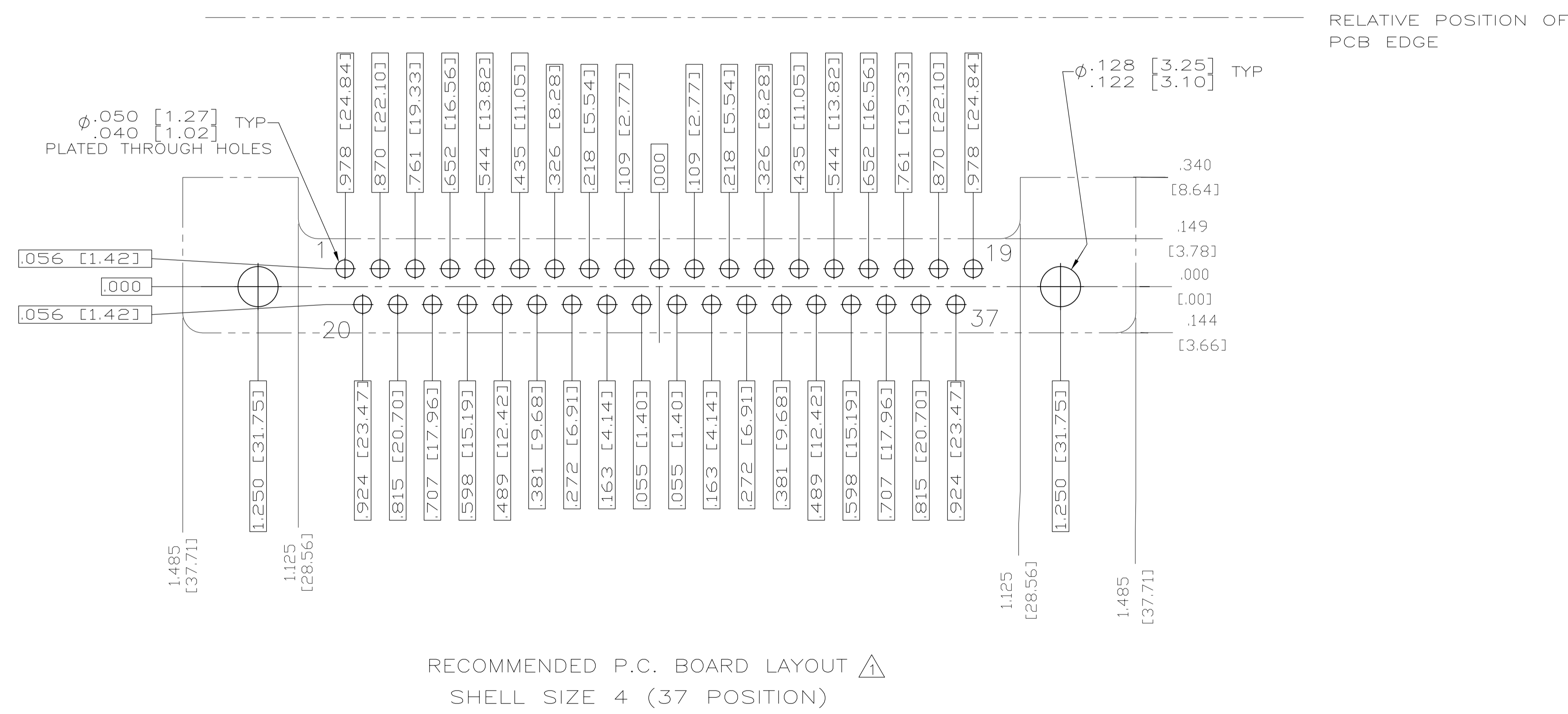
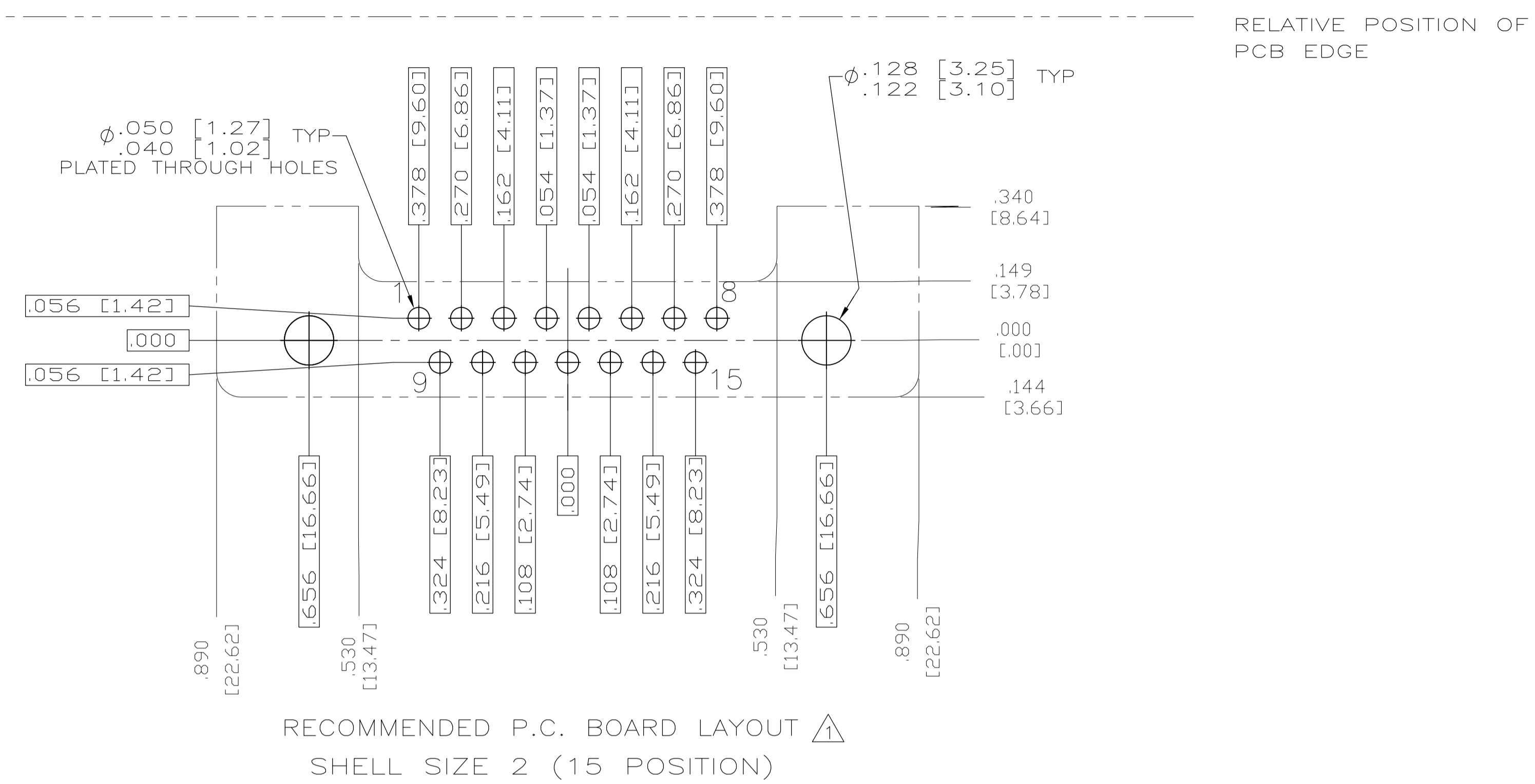

THIS DRAWING IS A CONTROLLED DOCUMENT. DIMENSIONING AND TOLERANCING PER ASME Y14.5M (ISO STANDARDS)		DWG: C.C.THOMAS 11-4-09	TE Connectivity
DIMENSIONS: INCHES [mm]		CHK: RELEASE 11-4-09	
TOLERANCES UNLESS OTHERWISE SPECIFIED:		APP'D: RELEASE 11-4-09	NAME: PLUG ASSEMBLY,AMPLIMITE,RT ANGLE SPECIAL, SERIES 109
0 PL ± - 1 PL ± - 2 PL ± - 3 PL ± .005 [0.13] 4 PL ± - ANGLES ± 1°		APPLICATION SPEC: -	SIZE: A1
MATERIAL: SEE CALLOUTS	FINISH: SEE CALLOUTS	WEIGHT: 0	CAGE CODE: 00779
CUSTOMER DRAWING		DRAWING NO: 2101619	RESTRICTED TO: -
SCALE: 4:1		SHEET: 2 OF 2	REV: U