

RECOMMENDED PTH PATTERN
SCALE 1:1

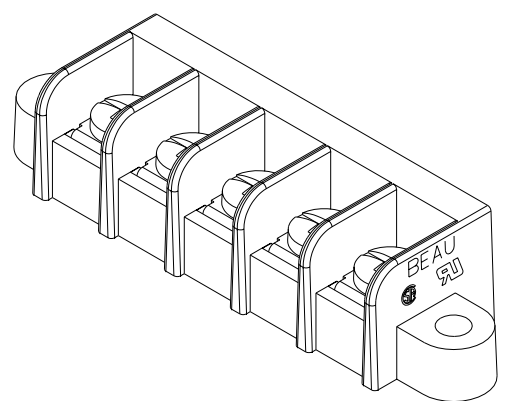

5 CIRCUIT SHOWN
Ø3.81 2 HOLES [.150]

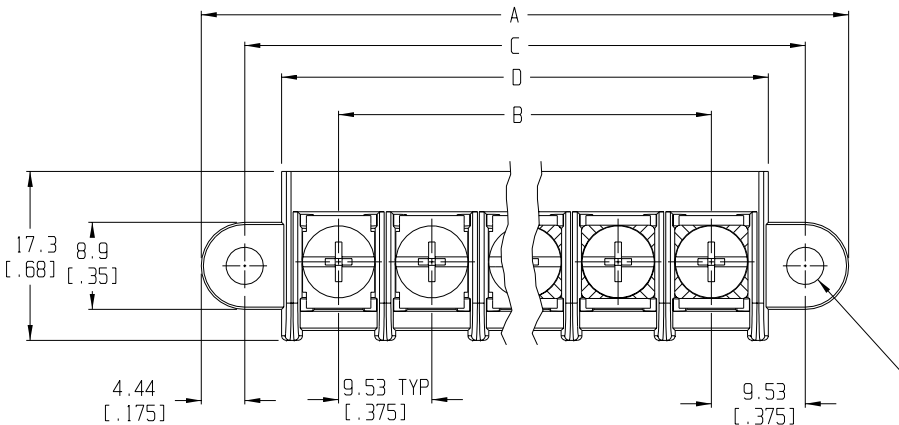
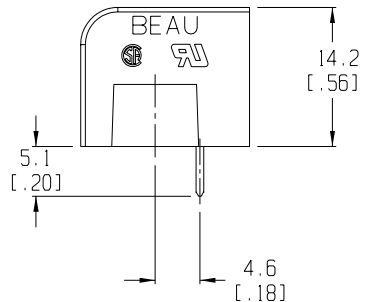
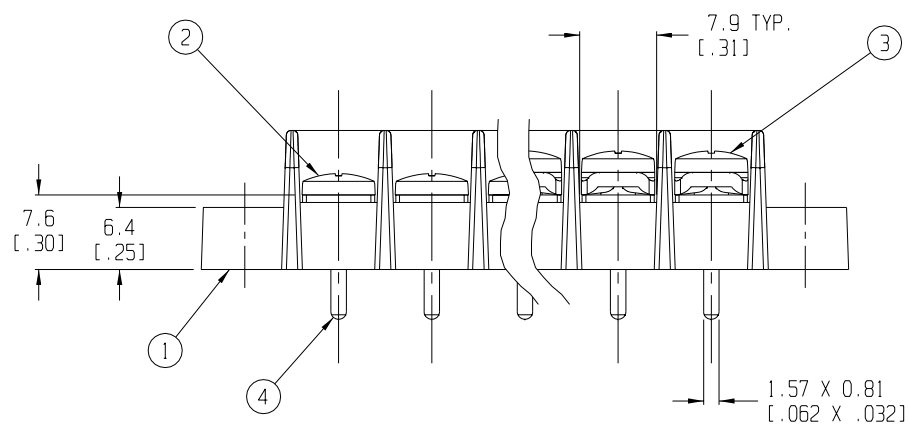

- NOTES:
1. MATERIAL: SEE TABLE
 2. FINISHES: SEE TABLE
 3. PRODUCT SPECIFICATION: UL & CSA, 12-24 AWG
 4. PACKAGING: NOT REQUIRED
 5. MATES WITH: NONE
 6. "XX" REFERS TO QTY. OF CIRCUITS
 7. LENGTH TABLE SHOWN ON SHEET 2
 8. REFER TO SD-38120-001 (-10A THRU -10D AND -11A THRU -11D) OR SD-38120-002 (-10AT THRU -10DT AND -11AT THRU -11DT) FOR OPTIONAL IMPRINTING.

ITEM	QTY.	DESCRIPTION	MATERIAL	FINISH
4	XX	TERMINAL	BRASS	TIN PLATE
3	XX	SCREW & WASHER (-50 OPT)	STEEL	ZINC CHROMATE
2	XX	SCREW (STD.)	STEEL	ZINC CHROMATE
1	1	BARRIER TERMINAL STRIP	THERMOPLASTIC	BLACK

EC NO. RELEASED DRWN: CLY CHK: APPR: REV A	DESCRIPTION MAJOR CRITICAL SPC	GENERAL TOLERANCES: (UNLESS SPECIFIED)	SCALE 2:1 DESIGN UNITS <input type="checkbox"/> mm <input checked="" type="checkbox"/> INCH	THIRD ANGLE PROJECTION	PROJECT NO. - DIMENSIONS: <input checked="" type="checkbox"/> mm <input type="checkbox"/> INCH <input type="checkbox"/> mm ONLY
		4 PLACES ±.0015 3 PLACES ±.038 ±.005 2 PLACES ±.13 ±.01 1 PLACE ±.3	DRAWN BY & DATE C. YORK 7-29-03	TITLE: SR BTS, PC TERMINAL	
		ANGULAR: ±2°	CHECKED BY & DATE APPROVED BY & DATE	MOLEX INCORPORATED	
		DRAFT WHERE APPLICABLE MUST REMAIN WITHIN DIMENSIONS	CAD FILENAME 755XX	MATERIAL NO. SEE SHEET 2 DRAWING NO. SD-38750-001 SHEET NO. 1 OF 2	

THIS DRAWING CONTAINS INFORMATION THAT IS PROPRIETARY TO MOLEX INCORPORATED AND SHOULD NOT BE USED WITHOUT WRITTEN PERMISSION.

10	9	8	7	5	4	3	2	1
----	---	---	---	---	---	---	---	---

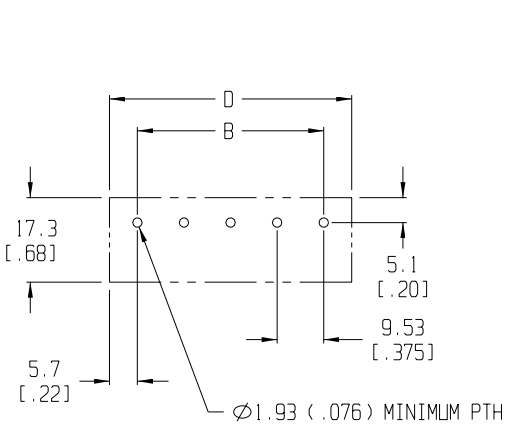

RECOMMENDED PTH PATTERN
SCALE 1:1

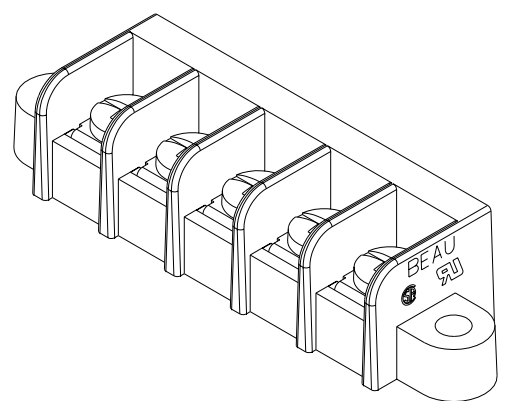
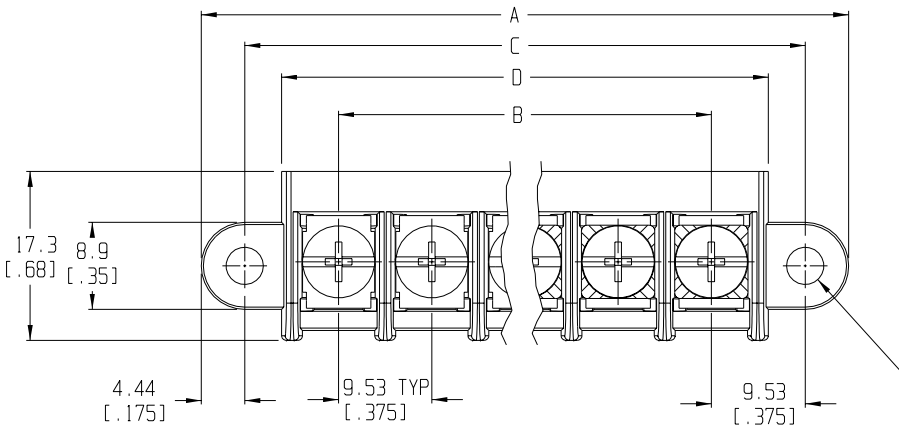

5 CIRCUIT SHOWN
Ø3.81 2 HOLES [.150]

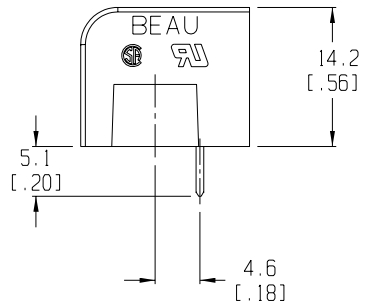
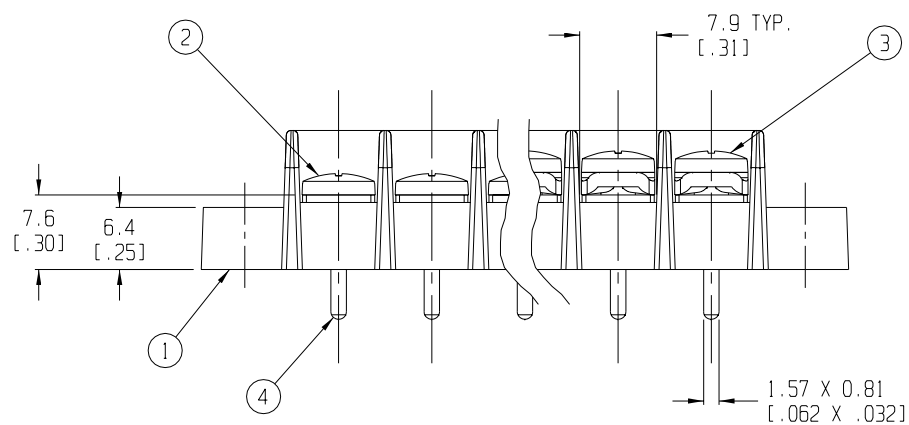

- NOTES:
1. MATERIAL: SEE TABLE
 2. FINISHES: SEE TABLE
 3. PRODUCT SPECIFICATION: UL & CSA, 12-24 AWG
 4. PACKAGING: NOT REQUIRED
 5. MATES WITH: NONE
 6. "XX" REFERS TO QTY. OF CIRCUITS
 7. LENGTH TABLE SHOWN ON SHEET 2
 8. REFER TO SD-38120-001 (-10A THRU -10D AND -11A THRU -11D) OR SD-38120-002 (-10AT THRU -10DT AND -11AT THRU -11DT) FOR OPTIONAL IMPRINTING.

ITEM	QTY.	DESCRIPTION	MATERIAL	FINISH
4	XX	TERMINAL	BRASS	TIN PLATE
3	XX	SCREW & WASHER (-50 OPT)	STEEL	ZINC CHROMATE
2	XX	SCREW (STD.)	STEEL	ZINC CHROMATE
1	1	BARRIER TERMINAL STRIP	THERMOPLASTIC	BLACK

RELEASED
CLY

EC NO. DRWN: CH'K: APPR:

REV

QUALITY SYMBOLS

MAJOR =

CRITICAL =

SPC =

GENERAL TOLERANCES:
(UNLESS SPECIFIED)

	mm	INCH
4 PLACES	±.0015	±.005
3 PLACES	±.038	±.005
2 PLACES	±.13	±.01
1 PLACE	±.3	

ANGULAR: ±2°

DRAFT WHERE APPLICABLE MUST REMAIN WITHIN DIMENSIONS

SCALE 2:1

DESIGN UNITS: mm INCH

THIRD ANGLE PROJECTION

TITLE: SR BTS, PC TERMINAL

MATERIAL NO. SEE SHEET 2

DRAWING NO. SD-38750-001

SHEET NO. 1 OF 2

SIZE B

PROJECT NO. -	I	-
DIMENSIONS:	SHT	REV
<input checked="" type="checkbox"/> mm <input type="checkbox"/> INCH	<input type="checkbox"/> mm <input type="checkbox"/> ONLY	REVISE ON CAD ONLY

THIS DRAWING CONTAINS INFORMATION THAT IS PROPRIETARY TO MOLEX INCORPORATED AND SHOULD NOT BE USED WITHOUT WRITTEN PERMISSION.

10 9 8 7 5 4 3 2 1