

REVISIONS					
REV	ECO	DESCRIPTION	DATE	BY	APPR
A1	--	RELEASED DRAWING	Jun-15-18	White	TOMMY
A2	--	UPDATE NOTES	Oct-18-2018	Blink	Tommy

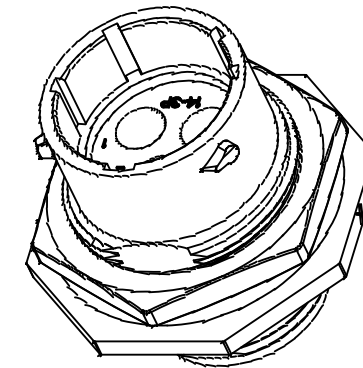

NOTES: (UNLESS OTHERWISE SPECIFIED)

- MATERIAL:
 - SHELL: THERMOPLASTIC, UL94 V-0.
 - INSERT: THERMOPLASTIC, UL94 V-0.
 - O-RING: NBR OR SILICONE RUBBER.
 - SEAL GASKET: NBR OR SILICONE RUBBER.
 - JAM NUT: ALUMINIUM ALLOY, BLACK ANODIZING.
- SPECIFICATIONS:
 - 2.1 RATED CURRENT: 45A (MAX).
 - 2.2 RATED VOLTAGE: 600V(AC/DC).
 - 2.3 OPERATING TEMPERATURE: SEE TABLE.
 - 2.4 DIELECTRIC WITHSTANDING VOLTAGE: LESS THAN 2 MILLIAMPS CURRENT LEAKAGE@2500 VOLTS AC.
 - 2.5 INSULATION RESISTANCE: 5000 MEGOHMS MIN.
 - 2.6 IP CLASS: IP67 AND IP69K IN THE MATED CONDITION, WIRE SEALS FULLY POPULATED.
 - 2.7 MATING CYCLES DURABILITY: 500 CYCLES MIN.
 - 2.8 RoHS COMPLIANT.
- SUITABLE CONTACTS : 8# CONTACT.

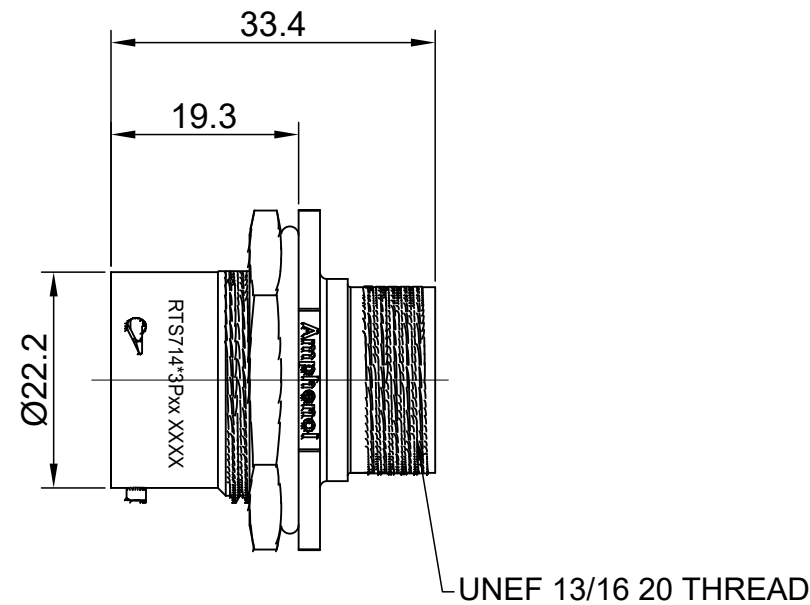
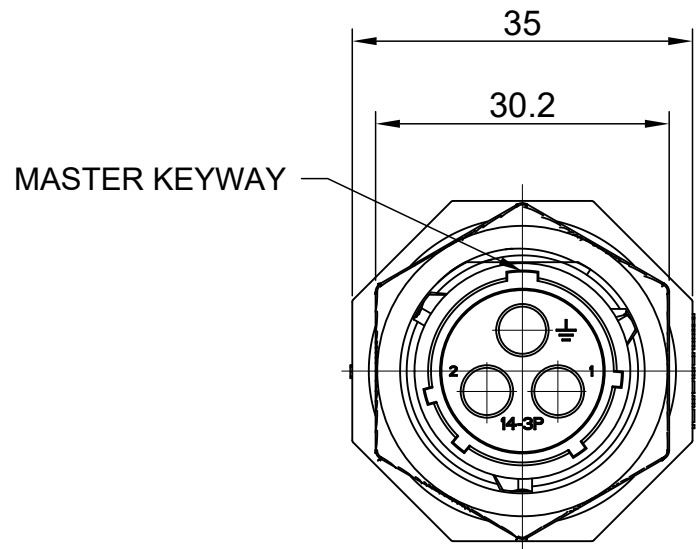
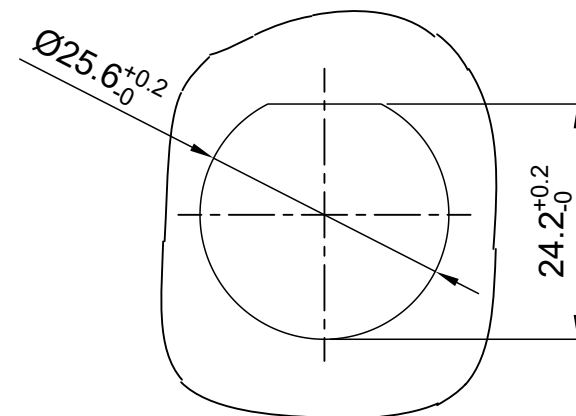

PANEL CUTOUT REFERENCE THICKNESS:3.2MM (MAX)

KEY	PART NUMBER	
	-40°C ~ 105°C	-40°C ~ 125°C
N	RTS714N3P	RTS714N3P03

A2

CONTACT SIZE	CONTACT PN	WIRE RANGE	CORD GRIP
8#	MP10A23x-25	16 - 14AWG	BACK SHELL
	MP10A23x-63	12 - 10AWG	
	MP10A23x-10	8 AWG	
	MP10A23xL	12 - 10AWG	END CAP

IN THE CONTACT PN,"x" DENOTE DIFFERENT PLATING.

- ALL DIMENSIONS ARE FOR REFERENCE USE ONLY.

TITLE: ECO-MATE RECEPTACLE, JAM NUT, SIZE 14,3POS,PIN
 DWG NO: RTS714*3Pxx
 REV: A2
 SH: 1
 OF: 1

QUANTITY	PART NUMBER	DESCRIPTION	ITEM
MATERIALS LIST			
UNLESS OTHERWISE SPECIFIED 1) All dimensions are in metric(mm). 2) Tolerances are as follows: 1 PL DEC ±0.30 2 PL DEC ±0.15 3 PL DEC ±0.08 Fractions ±1/64 Angles ±1° 3) Note reference =		Amphenol Sine Systems - www.amphenol-sine.com 44724 Morley Drive Clinton Township, MI 48036	
SIGNATURES DRAWN: Blink CHECKED: Tod ENGINEER: APPROVAL: Tommy		DATE Oct-18-2018 Oct-18-2018 Oct-18-2018	
MATERIAL SPECIFICATIONS:		CUSTOMER:	
PROCESS SPECIFICATIONS:		THIS DRAWING IS SUPPLIED FOR INFORMATION ONLY. DESIGN FEATURES, SPECIFICATIONS AND PERFORMANCE DATA SHOWN HEREON ARE THE PROPERTY OF THE AMPHENOL CORPORATION. NO RIGHTS OF REPRODUCTION ARE IMPLIED. ALL DIMENSIONS ARE SUBJECT TO NORMAL MANUFACTURING VARIATIONS.	
NEXT ASSY:		SIZE B	TYPE C-
		DWG NO: RTS714*3Pxx	REVISION A2
		SCALE: NONE	SHEET 1 OF 1