

Jul.1.2019 Copyright 2019 HIROSE ELECTRIC CO., LTD. All Rights Reserved.
 In case of consideration for using Automotive equipment / device which demand high reliability, kindly contact our sales window correspondents.

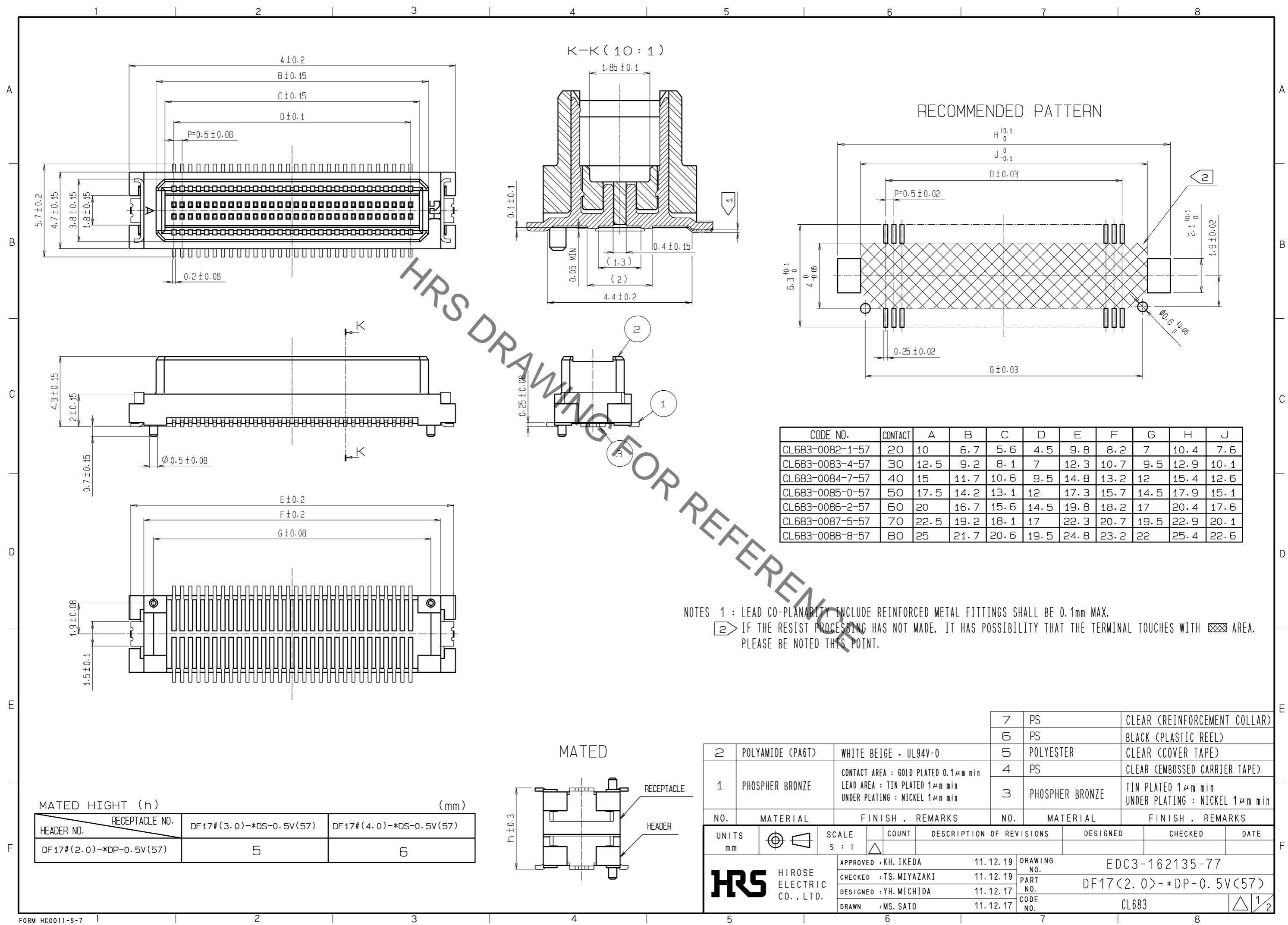

HRS DRAWING FOR REFERENCE

CODE NO.	CONTACT	A	B	C	D	E	F	G	H	J
CL683-0082-1-57	20	10	6.7	5.6	4.5	9.8	8.2	7	10.4	7.6
CL683-0083-4-57	30	12.5	9.2	8.1	7	12.3	10.7	9.5	12.9	10.1
CL683-0084-7-57	40	15	11.7	10.6	9.5	14.8	13.2	12	15.4	12.6
CL683-0085-0-57	50	17.5	14.2	13.1	12	17.3	15.7	14.5	17.9	15.1
CL683-0086-2-57	60	20	16.7	15.6	14.5	19.8	18.2	17	20.4	17.6
CL683-0087-5-57	70	22.5	19.2	18.1	17	22.3	20.7	19.5	22.9	20.1
CL683-0088-8-57	80	25	21.7	20.6	19.5	24.8	23.2	22	25.4	22.6

NOTES 1 : LEAD CO-PLANARITY INCLUDE REINFORCED METAL FITTINGS SHALL BE 0.1mm MAX.
 2 IF THE RESIST PROCESSING HAS NOT MADE, IT HAS POSSIBILITY THAT THE TERMINAL TOUCHES WITH AREA. PLEASE BE NOTED THIS POINT.

MATED HIGHT (h) (mm)

HEADER NO.	RECEPTACLE NO.	DF17#(3.0)-*DS-0.5V(57)	DF17#(4.0)-*DS-0.5V(57)
DF17#(2.0)-*DP-0.5V(57)	5	6	

NO.	MATERIAL	FINISH . REMARKS	NO.	MATERIAL	FINISH . REMARKS
2	POLYAMIDE (PA6T)	WHITE BEIGE , UL94V-0	7	PS	CLEAR (REINFORCEMENT COLLAR)
1	PHOSPHER BRONZE	CONTACT AREA : GOLD PLATED 0.1µm min LEAD AREA : TIN PLATED 1µm min UNDER PLATING : NICKEL 1µm min	6	PS	BLACK (PLASTIC REEL)
			5	POLYESTER	CLEAR (COVER TAPE)
			4	PS	CLEAR (EMBOSSED CARRIER TAPE)
			3	PHOSPHER BRONZE	TIN PLATED 1µm min UNDER PLATING : NICKEL 1µm min

UNITS	SCALE	COUNT	DESCRIPTION OF REVISIONS	DESIGNED	CHECKED	DATE
mm	5 : 1	△	APPROVED : KH. IKEDA 11.12.19			
			CHECKED : TS. MIYAZAKI 11.12.19			
			DESIGNED : YH. MICHIDA 11.12.17			
			DRAWN : MS. SATO 11.12.17			

DRAWING NO.	EDC3-162135-77
PART NO.	DF17(2.0)-*DP-0.5V(57)
CODE NO.	CL683

Jul.1.2019 Copyright 2019 HIROSE ELECTRIC CO., LTD. All Rights Reserved.
 In case of consideration for using Automotive equipment / device which demand high reliability, kindly contact our sales window correspondents.

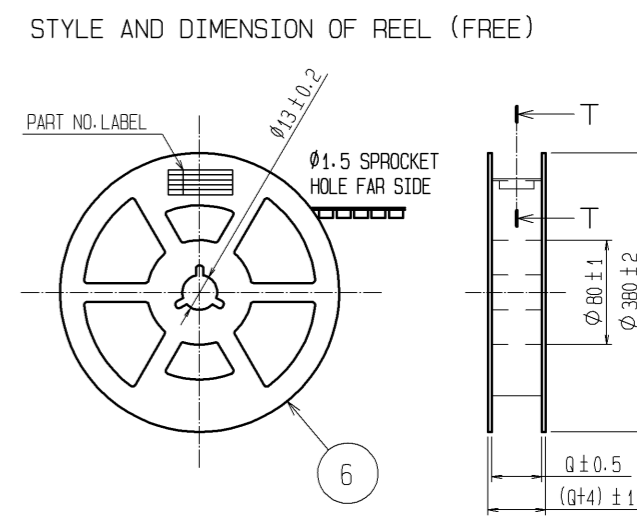
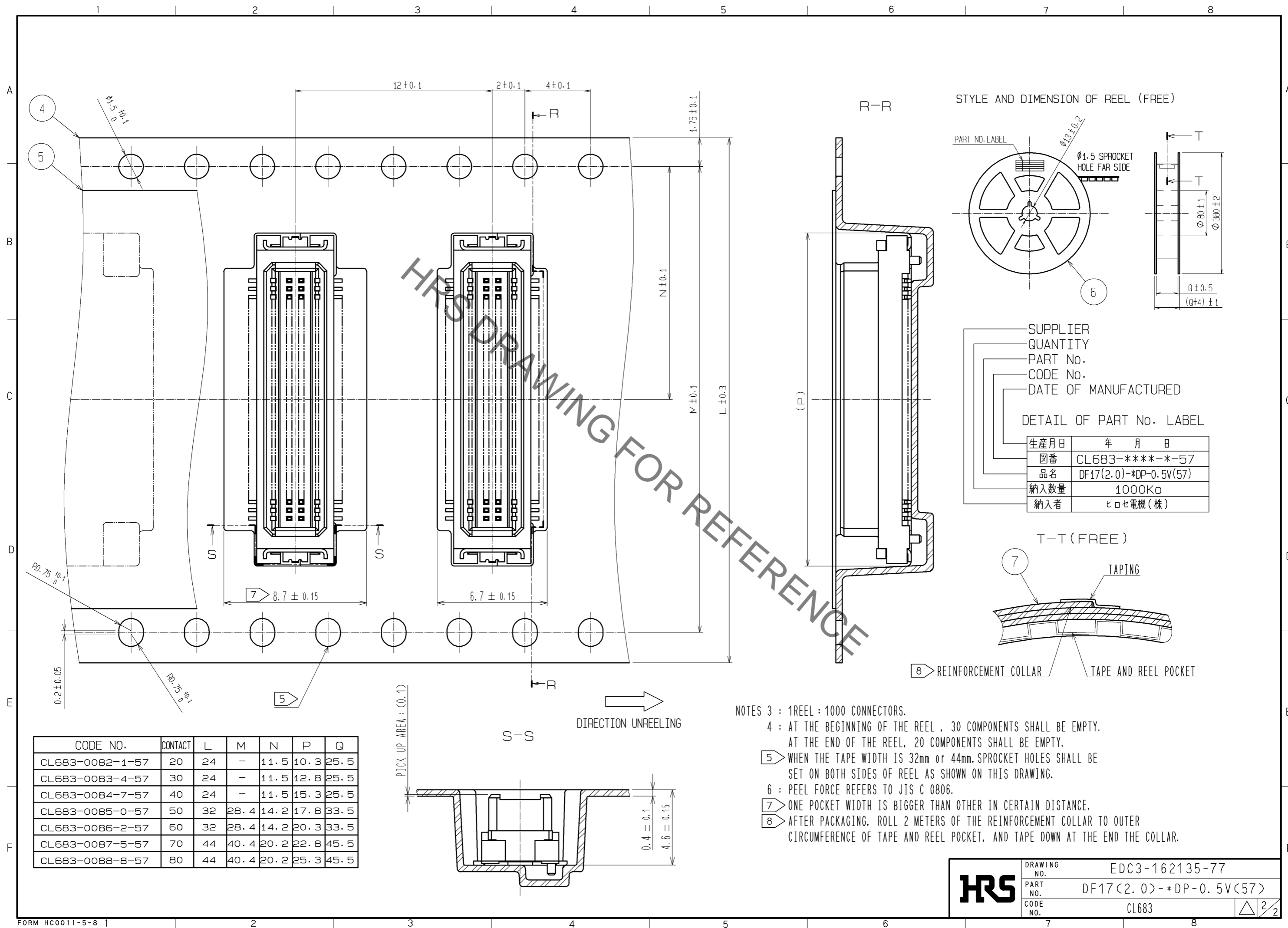

SUPPLIER
 QUANTITY
 PART No.
 CODE No.
 DATE OF MANUFACTURED

DETAIL OF PART No. LABEL

生産月日	年 月 日
図番	CL683-****-*-57
品名	DF17(2.0)-*DP-0.5V(57)
納入数量	1000K ϕ
納入者	ヒロセ電機(株)

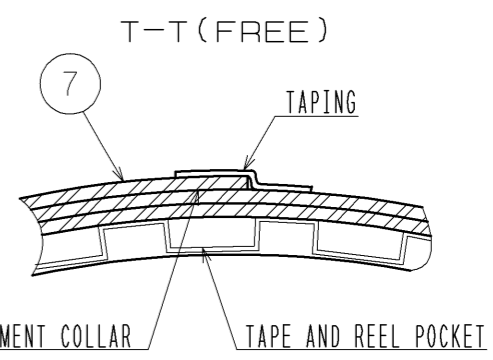

CODE NO.	CONTACT	L	M	N	P	Q
CL683-0082-1-57	20	24	-	11.5	10.3	25.5
CL683-0083-4-57	30	24	-	11.5	12.8	25.5
CL683-0084-7-57	40	24	-	11.5	15.3	25.5
CL683-0085-0-57	50	32	28.4	14.2	17.8	33.5
CL683-0086-2-57	60	32	28.4	14.2	20.3	33.5
CL683-0087-5-57	70	44	40.4	20.2	22.8	45.5
CL683-0088-8-57	80	44	40.4	20.2	25.3	45.5

- NOTES 3 : 1REEL : 1000 CONNECTORS.
 4 : AT THE BEGINNING OF THE REEL , 30 COMPONENTS SHALL BE EMPTY.
 AT THE END OF THE REEL, 20 COMPONENTS SHALL BE EMPTY.
 5 WHEN THE TAPE WIDTH IS 32mm or 44mm, SPROCKET HOLES SHALL BE SET ON BOTH SIDES OF REEL AS SHOWN ON THIS DRAWING.
 6 : PEEL FORCE REFERS TO JIS C 0806.
 7 ONE POCKET WIDTH IS BIGGER THAN OTHER IN CERTAIN DISTANCE.
 8 AFTER PACKAGING, ROLL 2 METERS OF THE REINFORCEMENT COLLAR TO OUTER CIRCUMFERENCE OF TAPE AND REEL POCKET, AND TAPE DOWN AT THE END THE COLLAR.

HRS	DRAWING NO.	EDC3-162135-77
	PART NO.	DF17(2.0)-*DP-0.5V(57)
	CODE NO.	CL683
		\triangle 2/2