

- NOTES:
 1. MATERIAL: STAINLESS STEEL
 2. HEAT TREAT: FINISHED HARDNESS
 3. ALL DIMENSION FOR REFERENCE ONLY

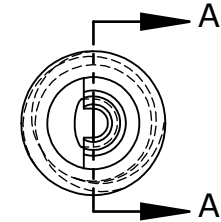

SECTION A-A

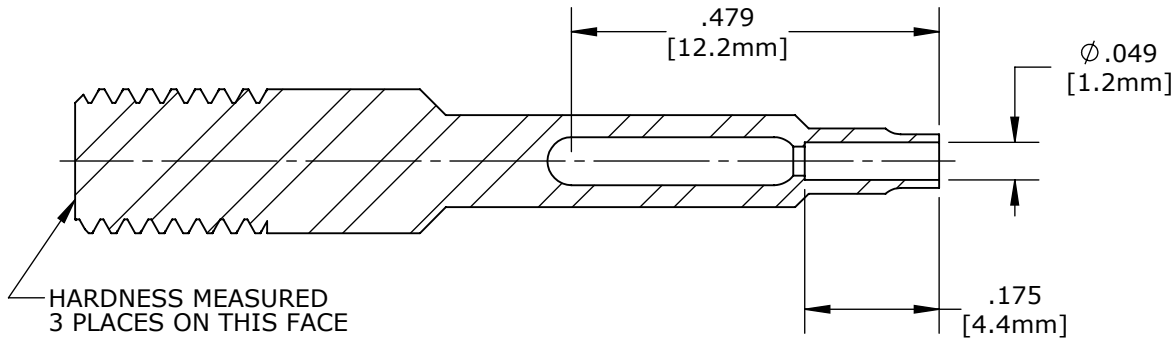
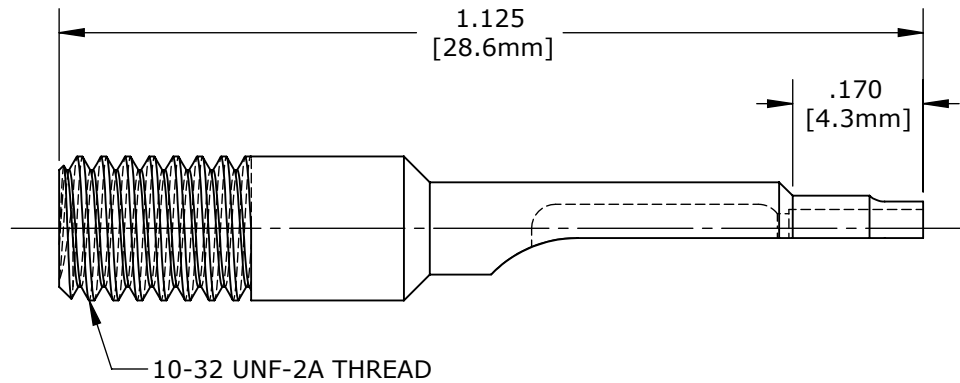

PROPRIETARY

THIS DOCUMENT CONTAINS CONFIDENTIAL INFORMATION PROPRIETARY TO CONXALL CORPORATION. ANY REPRODUCTION, DISCLOSURE, OR USE OF THIS DOCUMENT /INFORMATION IS EXPRESSLY PROHIBITED UNLESS AUTHORIZED IN WRITING BY CONXALL CORPORATION.

DIMENSIONS IN BRACKETS [] ARE METRIC

D	AN	06-13-17	CREATED SHEET PER DOR 17-7819JS		
REV.	INIT.	DATE	DESCRIPTION		
ALL INFORMATION ILLUSTRATED IS THE PROPERTY OF CONXALL CORPORATION. UNAUTHORIZED DUPLICATION OR DISTRIBUTION OF THIS DOCUMENT IS PROHIBITED.			ORIG. DRAWN BY:	DATE:	 601 E. WILDWOOD VILLA PARK, IL 60181
ALL UNITS ARE IN FEET, INCHES, FRACTION OF INCHES AND DECIMALS.			PAK	08-12-10	
= CRITICAL CHARACTERISTIC FLAG PER SPEC. XXXX			CHECKED BY:		TITLE:
			APPROVED BY:		CONTACT INSERTION BIT #22 CONTACTS PIN / SOCKET SIZE 22 AWG BARREL
SCALE	SIZE	SHEET	CUSTOMER:		REV
NTS	A	1 OF 1	FILE:	DIRECTORY:	D
			356-22-1	SLW	PART NUMBER: 356-22-1