

THIS DRAWING IS UNPUBLISHED. RELEASED FOR PUBLICATION ,19 .
 © COPYRIGHT 19 BY AMP INCORPORATED. ALL RIGHTS RESERVED.

LOC	DIST	REVISIONS			
P	LTR	DESCRIPTION	DATE	DWN	APVD
AF	50	B	REDRAWN PER 0710-0124-96	4/1/96	JR JH

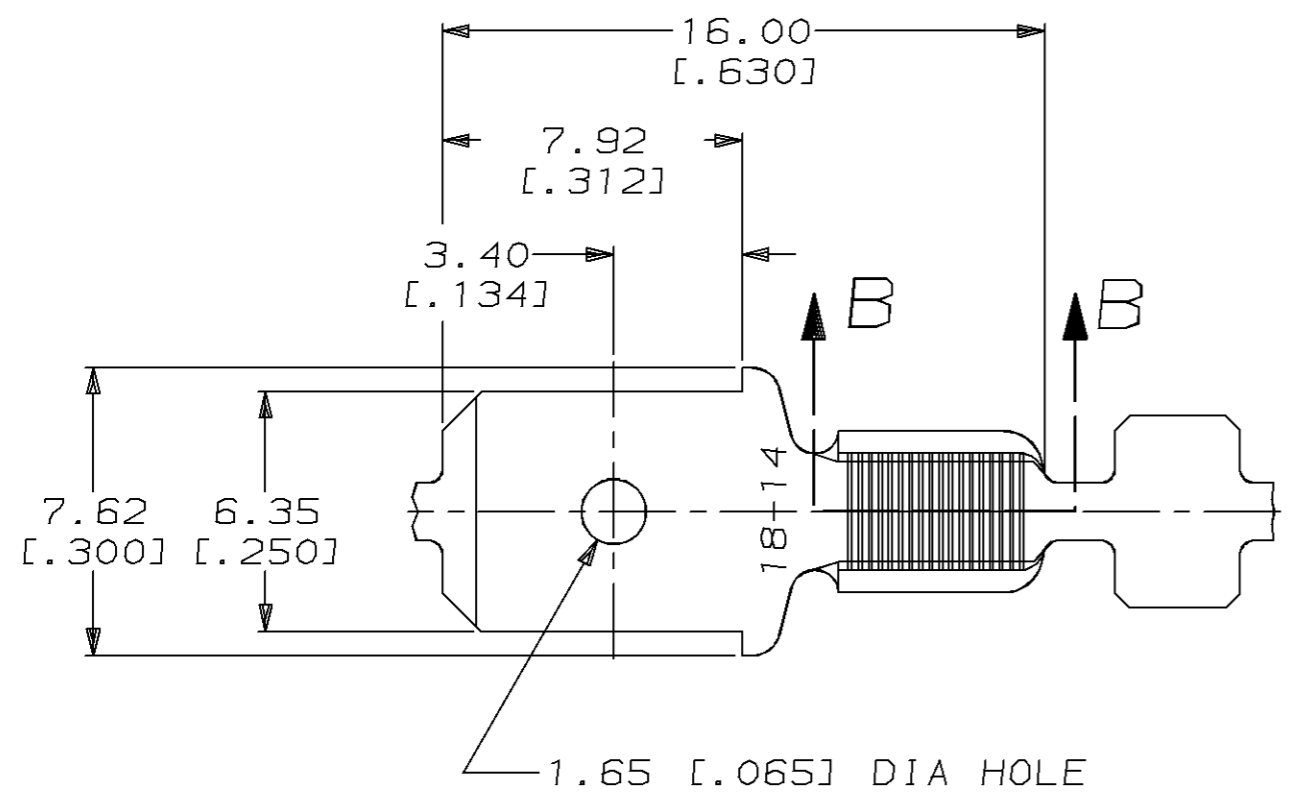

- 1 CONTINUOUS STRIP ON REELS.
- 2 WIRE SIZE IS 1.02-1.71mm DIA [#18-#14] MAGNET WIRE

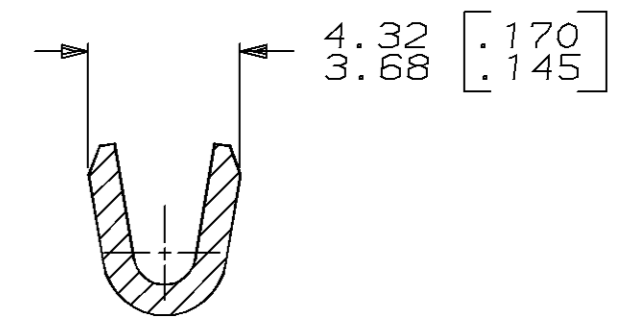
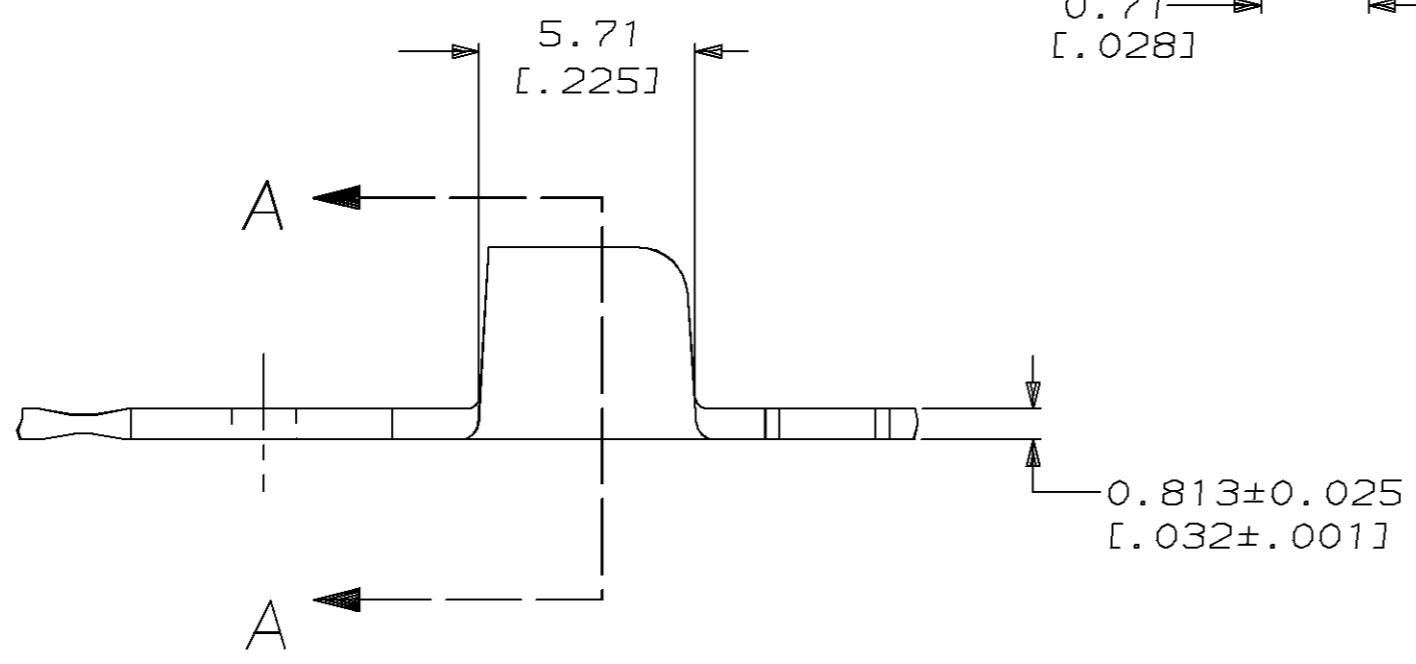
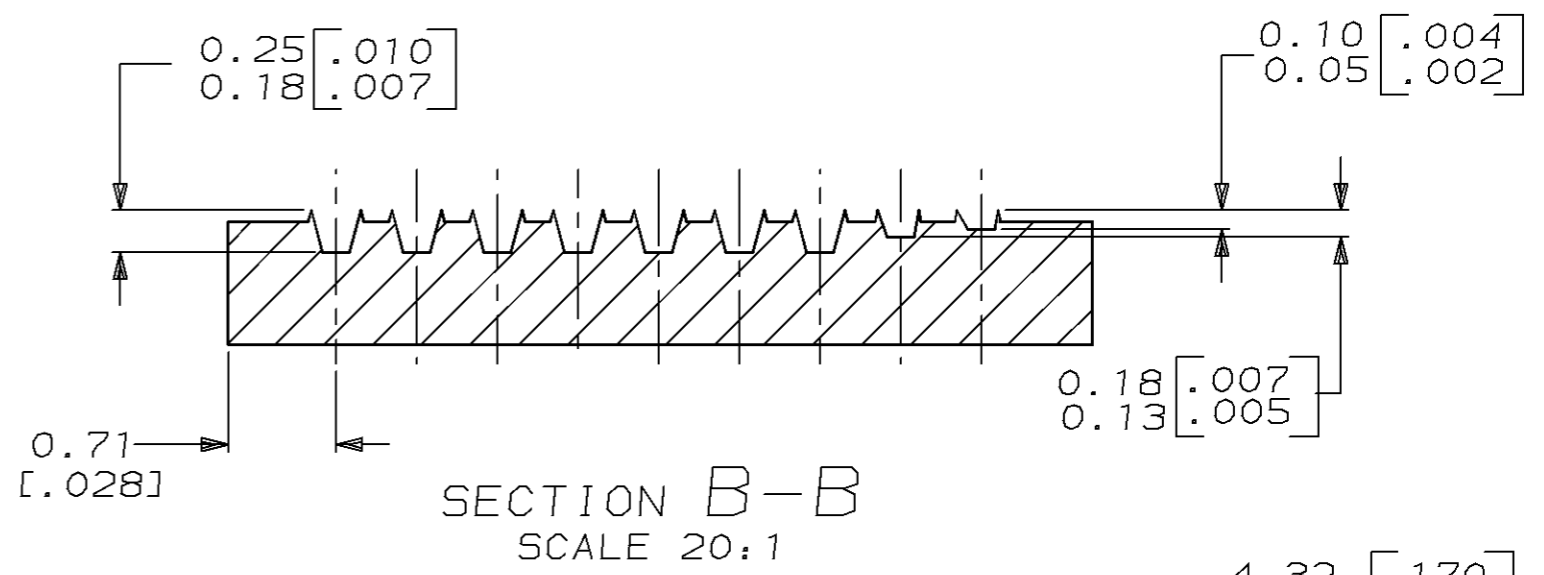

63349-1
 PART NO.

THIS DRAWING IS A CONTROLLED DOCUMENT FOR AMP INCORPORATED. IT IS SUBJECT TO CHANGE AND THE CONTROLLING ENGINEERING ORGANIZATION SHOULD BE CONTACTED FOR THE LATEST REVISION.		DWN JR RUTH 4/1/96	AMP AMP Incorporated Harrisburg, PA 17105-3608
		CHK M FEHER 4/1/96	
DIMENSIONS: mm		APVD P DESANTIS 4/1/96	NAME TAB, FASTON, AMPLIVAR, 6.35 [.250] SERIES (9 SERRATIONS)
TOLERANCES UNLESS OTHERWISE SPECIFIED: 0 PLC ±- 1 PLC ±- 2 PLC ±0.25 [.010] 3 PLC ±- 4 PLC ±- ANGLES ±1*		PRODUCT SPEC -	SIZE A3
MATERIAL 082 BRASS		APPLICATION SPEC -	CAGE CODE 00779
FINISH VARNISH RESIST OVER 0.002032 [.000080] MIN T/JN		WEIGHT -	DRAWING NO C-63349
		CUSTOMER DRAWING	SCALE 5:1
			SHEET 1 OF 1
			REV B