

P/N	CONTACT AREA PLATING	PACKAGE METHOD	REMARK
67490-1220	GOLD FLASH	WITHOUT MYLAR	PURE TIN
67490-1221	0.76 MICRONS GOLD PLATED	TRAY PACKAGE	
67490-1225	0.38 MICRONS GOLD PLATED	PK-67490-001	
67490-1230	GOLD FLASH	WITH MYLAR, TAPE REEL	
67490-1235	0.38 MICRONS GOLD PLATED	PK-67490-000	
67490-1240	GOLD FLASH	WITH MYLAR, TUBE PACKAGE	
67490-1245	0.38 MICRONS GOLD PLATED	PK-67490-002	

NOTES:

- MATERIAL:  
HOUSING: HIGH TEMPERATURE THERMAL PLASTIC  
GLASS FILLED, UL94V-0, COLOR: BLACK  
TERMINAL/FORKLOCK: COPPER ALLOY  
MYLAR: ADHENSIVE MYLAR 4.5MM X 15.5MM
- TERMINAL PLATING:  
CONTACT AREA: GOLD PLATED  
SOLDERING TAIL: 1.27 MICRONS MINIMUM TIN PLATED  
UNDER PLATE: NICKEL 1.27 MICRONS MINIMUM NICKEL PLATED
- FORKLOCK PLATING:  
1.27 MICRONS MINIMUM TIN PLATED OVERALL 1.27 MICRONS MINIMUM NICKEL UNDER-PLATED
- PACKAGING SPECIFICATION REFER TO TABLE
- PRODUCT SPECIFICATION REFER TO PS-67490-001
- MATING PART: 67538, 67489

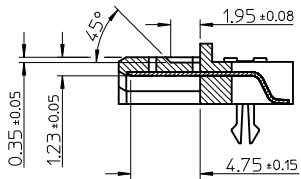
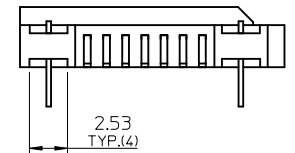
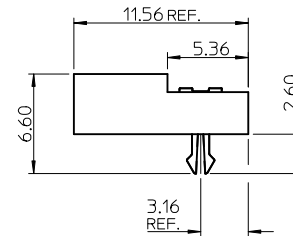
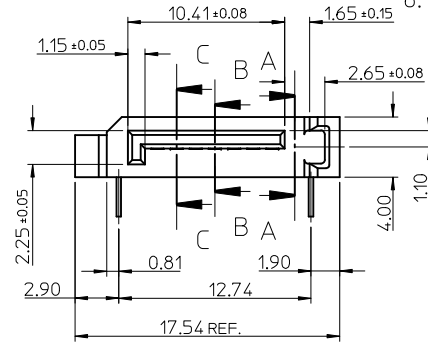
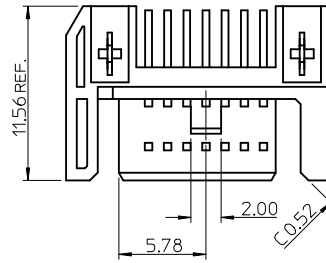

SECTION B-B  
SCALE 3:1

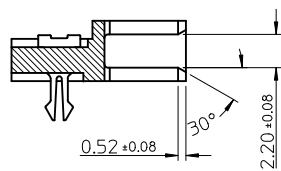

SECTION A-A  
SCALE 3:1

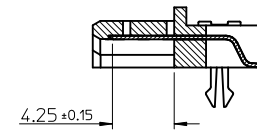
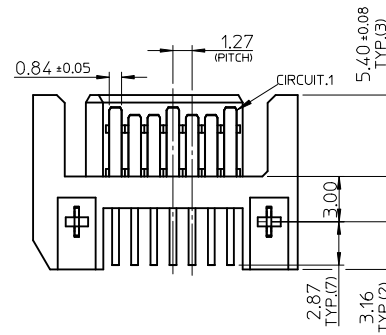

SECTION C-C  
SCALE 3:1

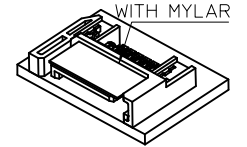

WITH MYLAR

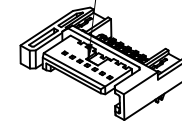

WITHOUT MYLAR

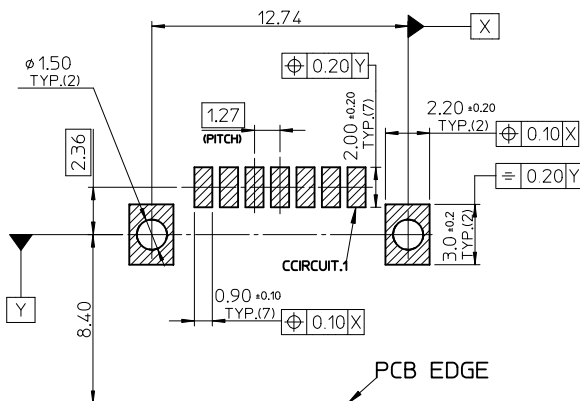

RECOMMEND P.C.B. LAYOUT (t=1.6)

REV	DESCRIPTION	DATE	BY	APPR.
1	REMOVE PART NUMBER	2012/01/18	SH2012-0062	
2		2012/01/30	DRWN:XQZHANG	
3		2012/02/02	CHKD:XQZHANG	
4			APPR:AYIN	

QUALITY SYMBOLS	GENERAL TOLERANCES (UNLESS SPECIFIED)	
	mm	INCH
$\nabla_{\sqrt{A}}=0$	4 PLACES ± ---	± ---
$\nabla_{\sqrt{B}}=0$	3 PLACES ± ---	± ---
$\nabla_{\sqrt{C}}=0$	2 PLACES ± 0.15	± ---
$\nabla_{\sqrt{D}}=0$	1 PLACE ± 0.25	± ---
	ANGULAR ± 3°	

DIMENSION STYLE		SCALE	DESIGN UNITS	THIRD ANGLE PROJECTION
MM ONLY		4:1	METRIC	
DRAWN BY	DATE	TITLE		
RICHARD	'01/08/08	SATA SYSTEM PLUG		
CHECKED BY	DATE	R/A STANDARD TYPE		
VINCENT	'01/08/08			
APPROVED BY	DATE			
ERICK	'01/08/08			
MATERIAL NO.	DOCUMENT NO.			
SEE TABLE	SD-67490-002			
SIZE	THIS DRAWING CONTAINS INFORMATION THAT IS PROPRIETARY TO MOLEX INCORPORATED AND SHOULD NOT BE USED WITHOUT WRITTEN PERMISSION			
A3				

MATERIAL NO.		DOCUMENT NO.	SHEET NO.
SEE TABLE		SD-67490-002	1 OF 1