

THIS DRAWING IS UNPUBLISHED. RELEASED FOR PUBLICATION
 © COPYRIGHT - By - ALL RIGHTS RESERVED.

REVISIONS					
P	LTR	DESCRIPTION	DATE	DWN	APVD
B1		ADJUST PCB LAYOUT DIM SCALE	19JAN2021	J.J	N.S

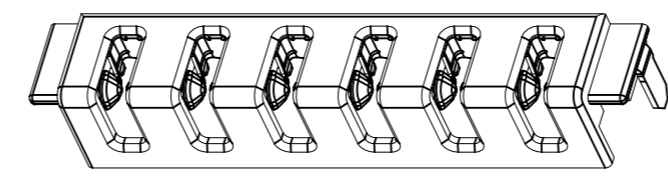

1932869-2:AS SHOWN

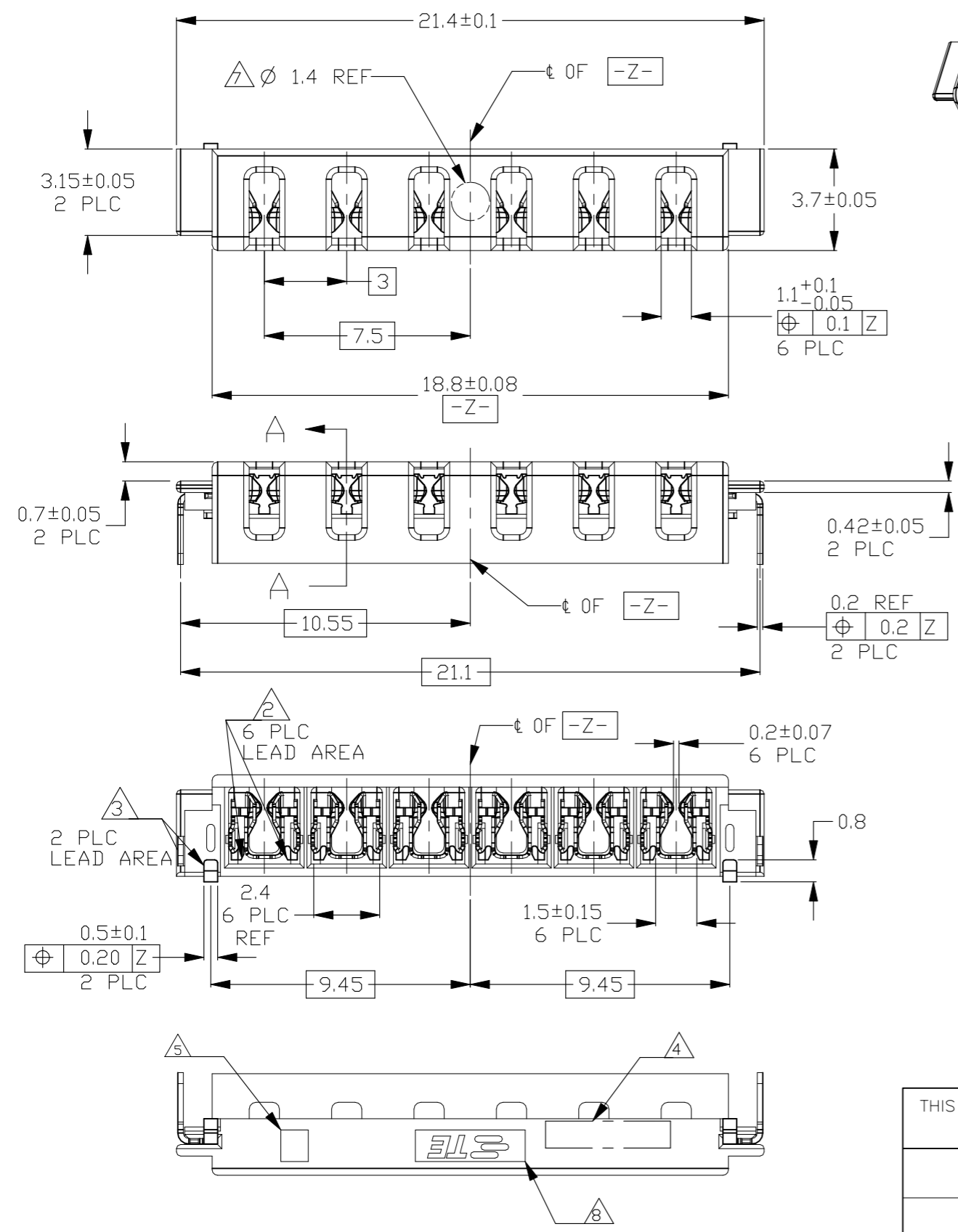
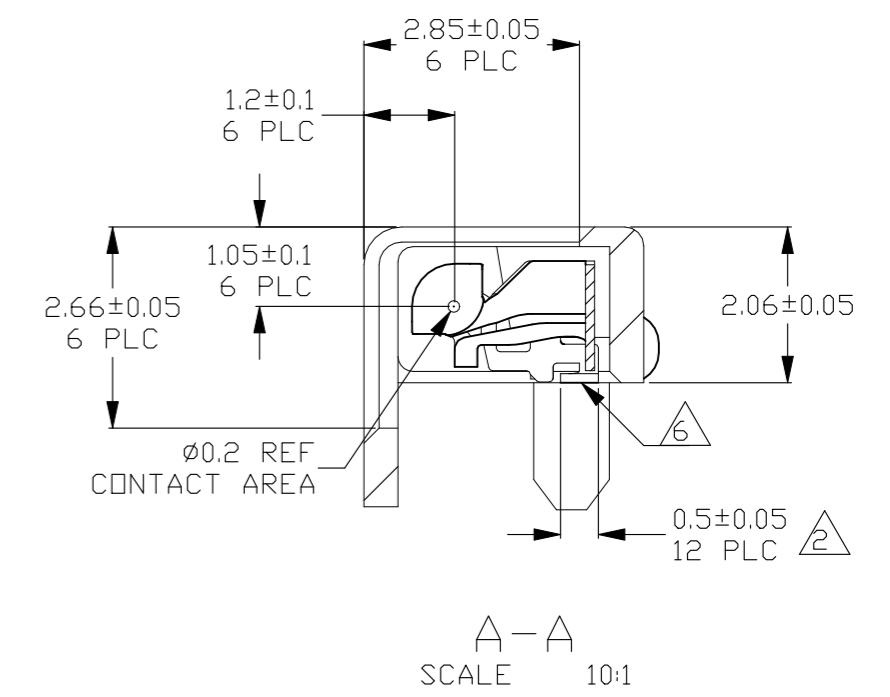
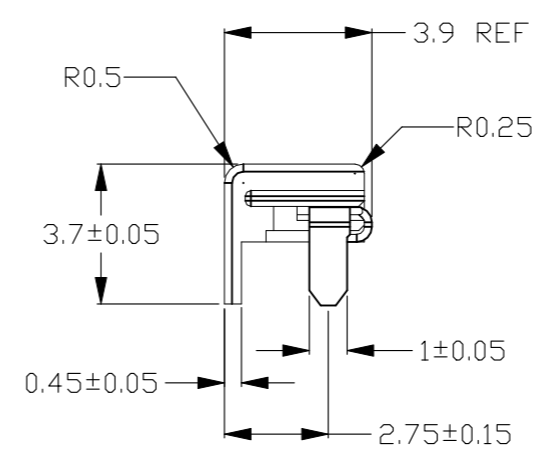

- 1 MATERIAL
CONTACT: COPPER ALLOY
HOUSING: LCP UL94V-0, BLACK
SOLDER PEG: BRASS
- 2 FINISH
CONTACT: NICKEL ALL OVER UNDER PLATING, 2.54µm MIN.
GOLD PLATING (REF ASTM B488, TYPE 2, GRADE C (130-200KnoP))
1.27µm MIN AT CONTACT AREA.
GOLD FLASH PLATING AT LEAD AREA, 0.05-0.13µm
- 3 FINISH
SOLDER PEG: NICKEL ALL OVER UNDER PLATING, OVER 2µm
TIN PLATING ALL OVER, 2-5µm, LEAD FREE
- 4 DATE CODE: 5 DIGITS.
- 5 MOLD CAVITY ID.
- 6 COPLANARITY: 0.08MAX.
- 7 PICKING AREA
- 8 TRADE MARK

1	2	1932869-2
FINISH		PART NUMBER

THIS DRAWING IS A CONTROLLED DOCUMENT.		DWN Tony.Zhang 6JULY2011	TE Connectivity	
DIMENSIONS: mm		CHK Yohei.Harada 6JULY2011		
TOLERANCES UNLESS OTHERWISE SPECIFIED:		APVD Steven Yao 6JULY2011	NAME FBIS-II	
0 PLC ± 0.3	1 PLC ± 0.3	PRODUCT SPEC 108-1691	RECEPTACLE ASSEMBLY ASSEMBLY 6 POS	
2 PLC ± 0.3	3 PLC ± -	APPLICATION SPEC -	SIZE A3	CAGE CODE 00779
4 PLC ± -	ANGLES ± 3°	WEIGHT 0.19	DRAWING NO C-1932869	RESTRICTED TO -
MATERIAL 1 -	FINISH 2 -	CUSTOMER DRAWING		SCALE 5:1
			SHEET 1 OF 3	REV B1

THIS DRAWING IS UNPUBLISHED. RELEASED FOR PUBLICATION
 © COPYRIGHT - By - ALL RIGHTS RESERVED.

REVISIONS					
P	LTR	DESCRIPTION	DATE	DWN	APVD
-	-	SEE SHEET 1	-	-	-

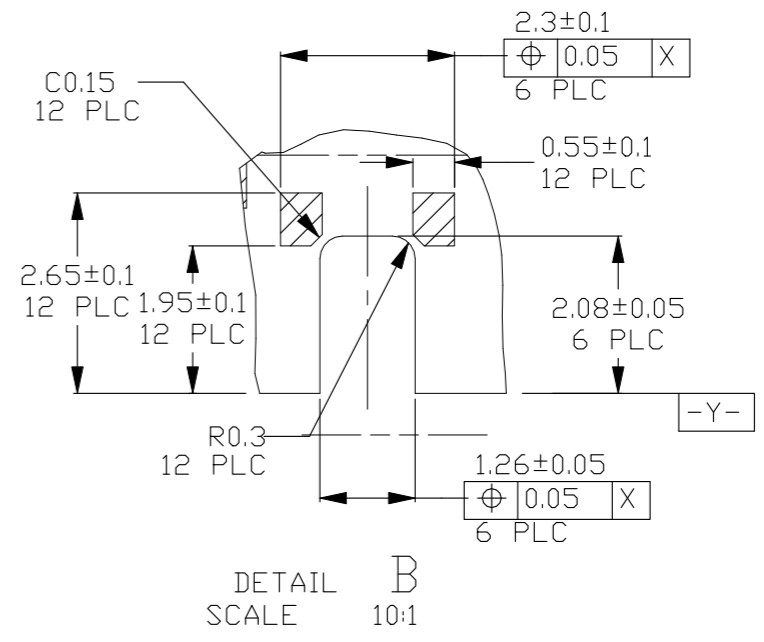
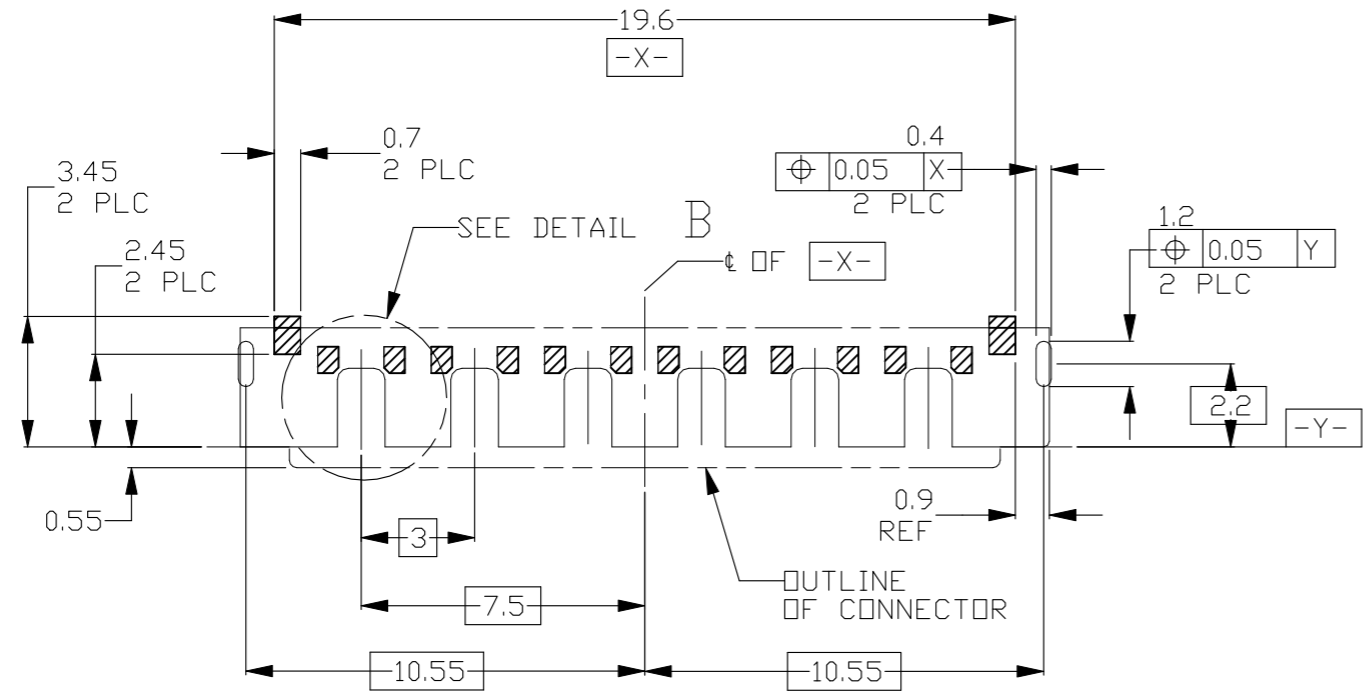

RECOMMENDED SMALL PCB LAYOUT
 (GENERAL TOLERANCE: ± 0.05, SCALE 5:1)

THIS DRAWING IS A CONTROLLED DOCUMENT.		DWN Tony Zhang 6JULY2011	TE Connectivity			
DIMENSIONS: mm		CHK Yohei Harada 6JULY2011				
TOLERANCES UNLESS OTHERWISE SPECIFIED:		APVD Steven Yao 6JULY2011	NAME			
0 PLC ± 0.3 1 PLC ± 0.3 2 PLC ± 0.3 3 PLC ± - 4 PLC ± - ANGLES ± 3°		PRODUCT SPEC 108-1691	FBIS-II			
MATERIAL		APPLICATION SPEC	RECEPTACLE ASSEMBLY 6 POS			
FINISH		WEIGHT 0.19	SIZE A3	CAGE CODE 00779	DRAWING NO C-1932869	RESTRICTED TO
		CUSTOMER DRAWING	SCALE 1:1	SHEET 2 OF 3	REV B1	

4

3

2

1

THIS DRAWING IS UNPUBLISHED. RELEASED FOR PUBLICATION
 © COPYRIGHT - By - ALL RIGHTS RESERVED.

REVISIONS					
P	LTR	DESCRIPTION	DATE	DWN	APVD
-	-	SEE SHEET 1	-	-	-

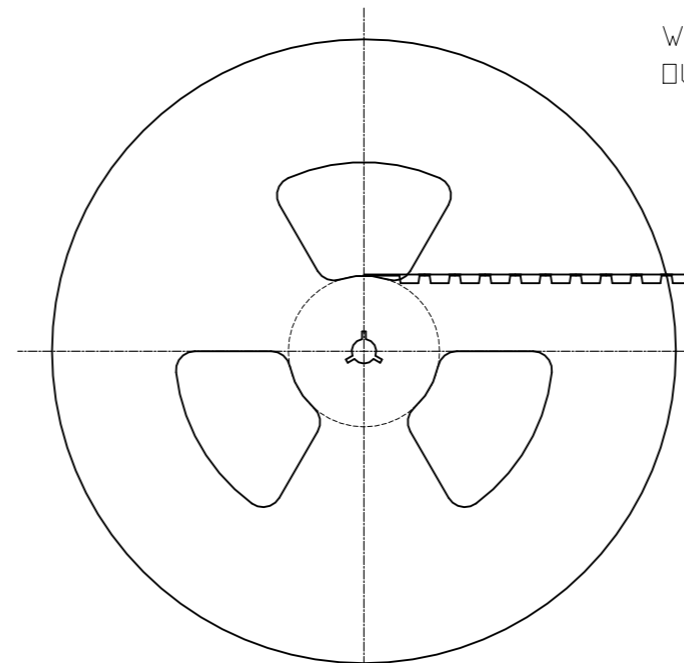
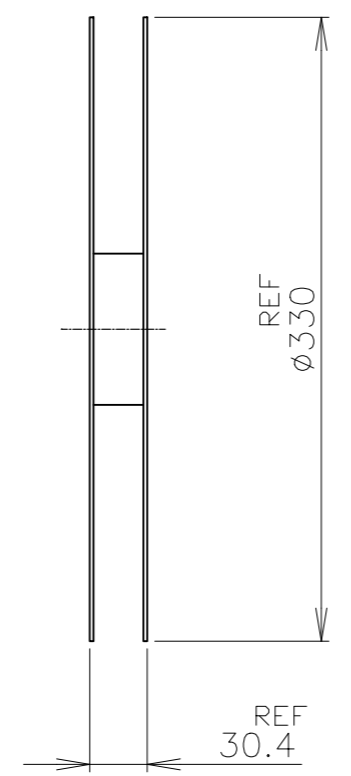
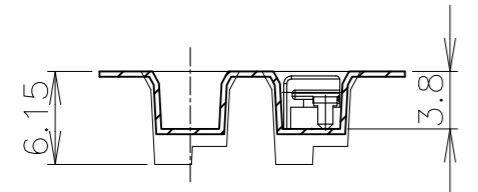
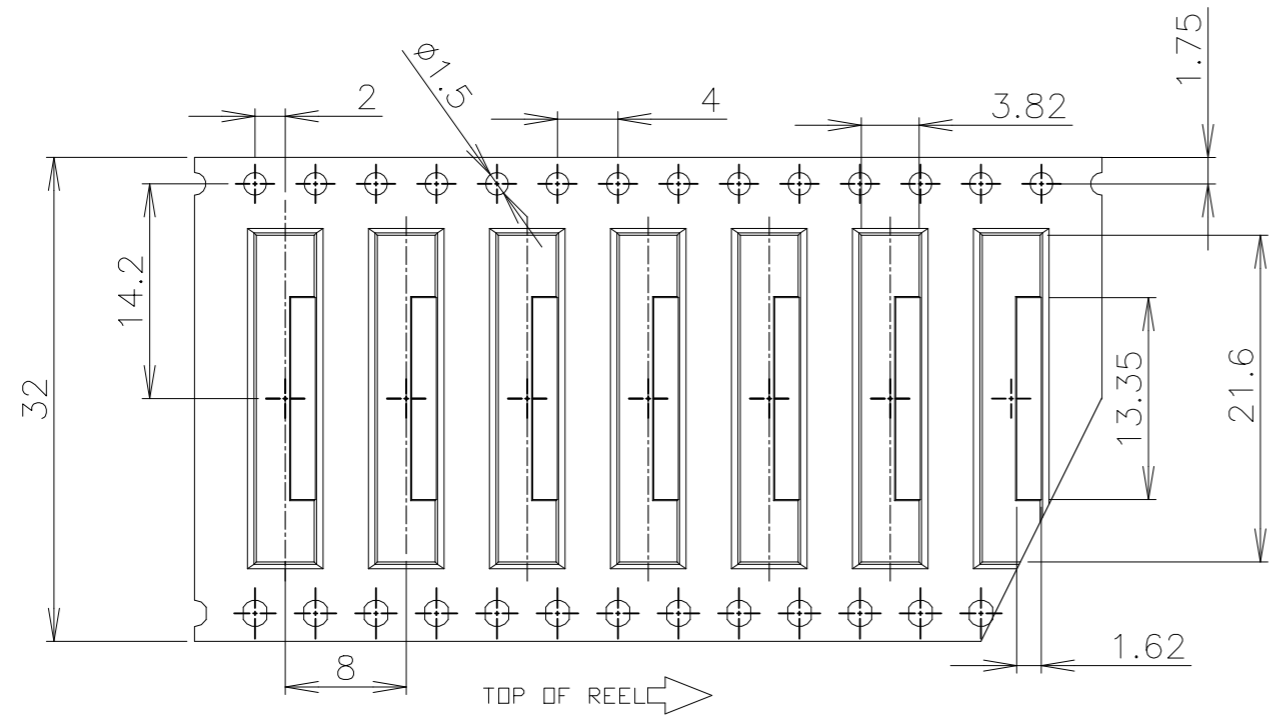

PEELING STRENGTH
 0.1-1.3N MAX(300±10mm/min)
 PEELING ANGLE
 165-180°

WIDE COVER TAPE AROUND
 OUT PERIPHERY 1 TURN

TOP OF REEL

2000EA/REEL

WITHOUT CHARGE 300mm APPROX WITH PRODUCT CHARGE 600mm APPROX WITHOUT CHARGE

THIS DRAWING IS A CONTROLLED DOCUMENT.		DWN Tony Zhang 6JULY2011	TE Connectivity			
DIMENSIONS: mm		CHK Yohei Harada 6JULY2011				
TOLERANCES UNLESS OTHERWISE SPECIFIED:		APVD Steven Yao 6JULY2011	NAME FBIS-II			
0 PLC ± 0.1 1 PLC ± 0.1 2 PLC ± 0.1 3 PLC ± - 4 PLC ± - ANGLES ± 3°		PRODUCT SPEC 108-1691	RECEPTACLE ASSEMBLY ASSEMBLY 6 POS			
MATERIAL		APPLICATION SPEC	SIZE	CAGE CODE	DRAWING NO	RESTRICTED TO
-		FINISH	-	-	A3 00779 C-1932869	-
CUSTOMER DRAWING			WEIGHT 0.19	SCALE 5:1	SHEET 3 OF 3	REV B1