

6

5

4

3

2

1

APPROVED: \_\_\_\_\_

DATE: \_\_\_\_\_ TITLE: \_\_\_\_\_

Rev	AWO #	Description	Date	Appr
-		RELEASED	11/1/22	
A		UPDATED SPEC.	11/30/22	JJ/RC

D

D

C

C

B

B

A

A

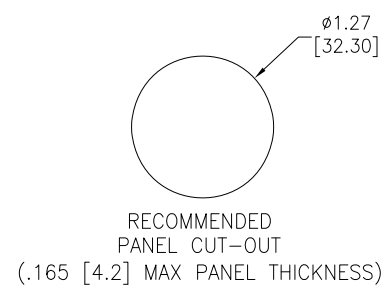
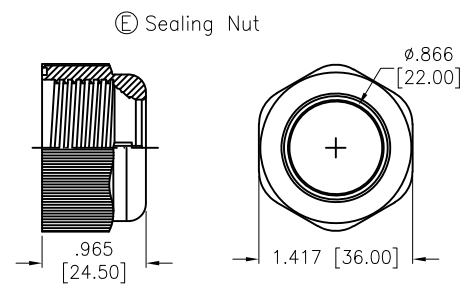
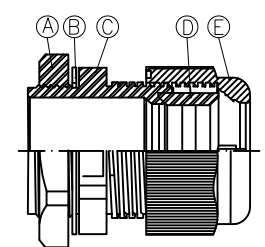
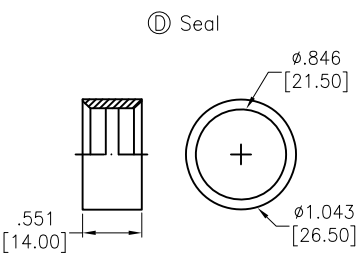
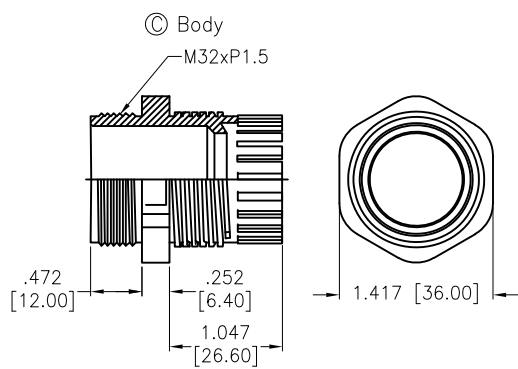
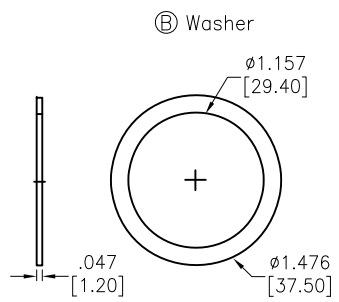
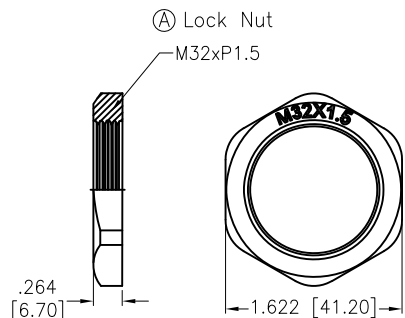

SPECIFICATIONS:

- Material:
- Lock Nut: PA66, rated UL 94V-2
- Body: PA66, rated UL 94V-2
- Sealing Nut: PA66, rated UL 94V-2
- Washer: NBR
- Seal: NBR
- Mechanical:
- Cable Range (O.D.): 16-21mm
- Thread O.D. L2: 32mm
- Thread Length L2: 12mm
- Spanner Size A&E: 38/36mm
- Nut Torque: 3Nm Max.
- Environmental:
- Waterproof: IP68
- Lead free, RoHS compliant.



UNLESS OTHERWISE SPECIFIED ALL DIMENSIONS ARE INCHES [MM]. TOLERANCES: EXCEPT AS NOTED		
INCHES	HOLES	
.X ± .10	Ø.X	± .10
.XX ± .020	Ø.XX	± .015
.XXX ± .015	Ø.XXX	± .010
DRAWN	WX	11/1/22
CHECKED	RC	11/1/22
APPROVED		
THIS DRAWING CONTAINS INFORMATION THAT IS PROPRIETARY AND SHOULD NOT BE USED WITHOUT PRIOR WRITTEN PERMISSION FROM ADAM TECH		

**ADAM TECH** 909 Rahway Avenue, Union, NJ 07083  
Phone: 908-687-5000 Fax: 908-687-5710

TITLE: WATERPROOF CONNECTOR, M32, 1 HOLE, CABLE GLAND WATERPROOF: IP68

SIZE	PART NO.	REV.
X	CG-P-M32-1.5	A

REF: S00211C SCALE: NTS SHEET 1 OF 1

6

5

4

3

2

1