

PART NUMBER	REV	FIRST USED	LEADMAKER	MECH POST FEED
687890-1	J	854400-1	LEADMAKER	MECH POST FEED
687890-2	B	565435-5	BENCH MODEL K	MECH POST FEED
687890-3	J	565435-5	BENCH MODEL K	MECH PRE FEED
687890-4	D	565435-5	BENCH MODEL K	MECH PRE FEED
687890-5			SEE DWG 687890-5	
687890-6	J	354500-1	BENCH MODEL G	MECH PRE FEED

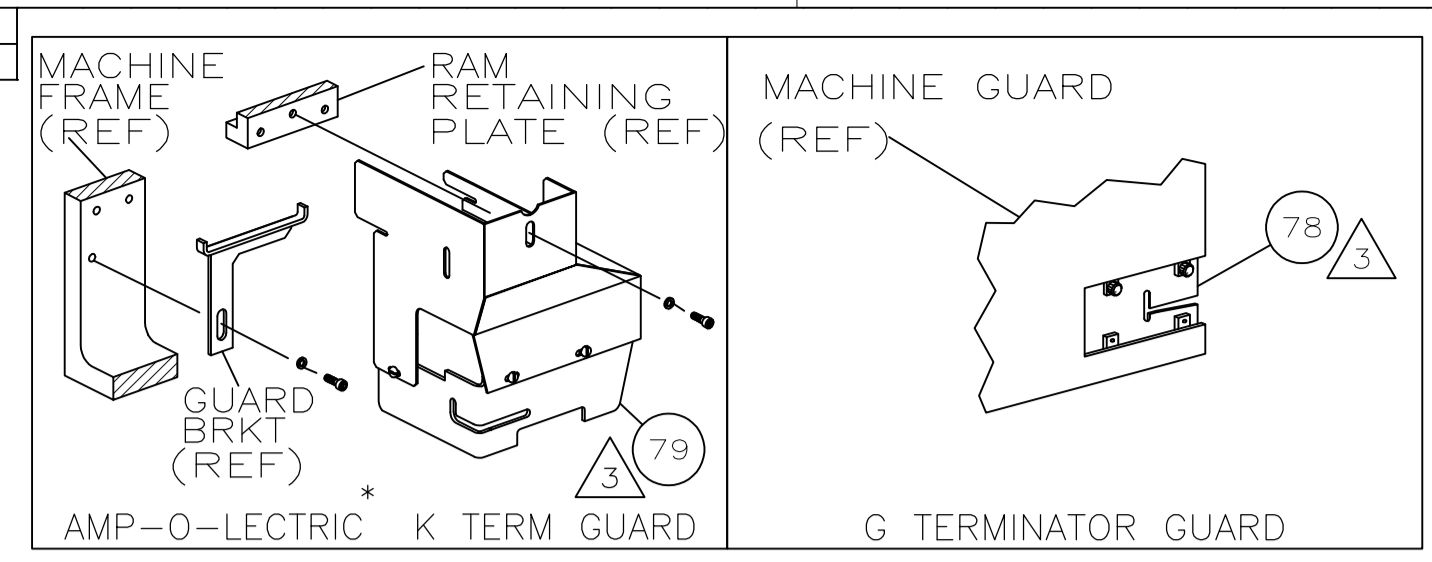

TERMINAL NAME:		CRIMPING DATA			
PIN RECEPTACLE		PAD LTR	CRIMP HEIGHT GROUP I	WIRE SIZE	CRIMP HEIGHT GROUP II
GROUP I (.012 THK)	GROUP II (.014 THK)	A	.054 ±.002	18	.058 ±.002
41854	42143	B	.049 ±.002	20	.053 ±.002
41870	42109	C	.046 ±.002	22	.050 ±.002
60031		D	NOT	-	USED
63595		CRIMP	SIZE	TYPE	RANGE
1742350		WIRE	.070	F	22-18
		INSUL	.155	0	.090-.130
		FEED	APPL INST	SET UP GAGE	LAYOUT
		.625	408-8039	458638-1	L27
			WIRE STRIP LENGTH	.140-.170	

LOC	DIST	REVISIONS			
A	66	REV	DESCRIPTION	DATE	BY
		J1	ECR-08-001616	1-2008	MY TE

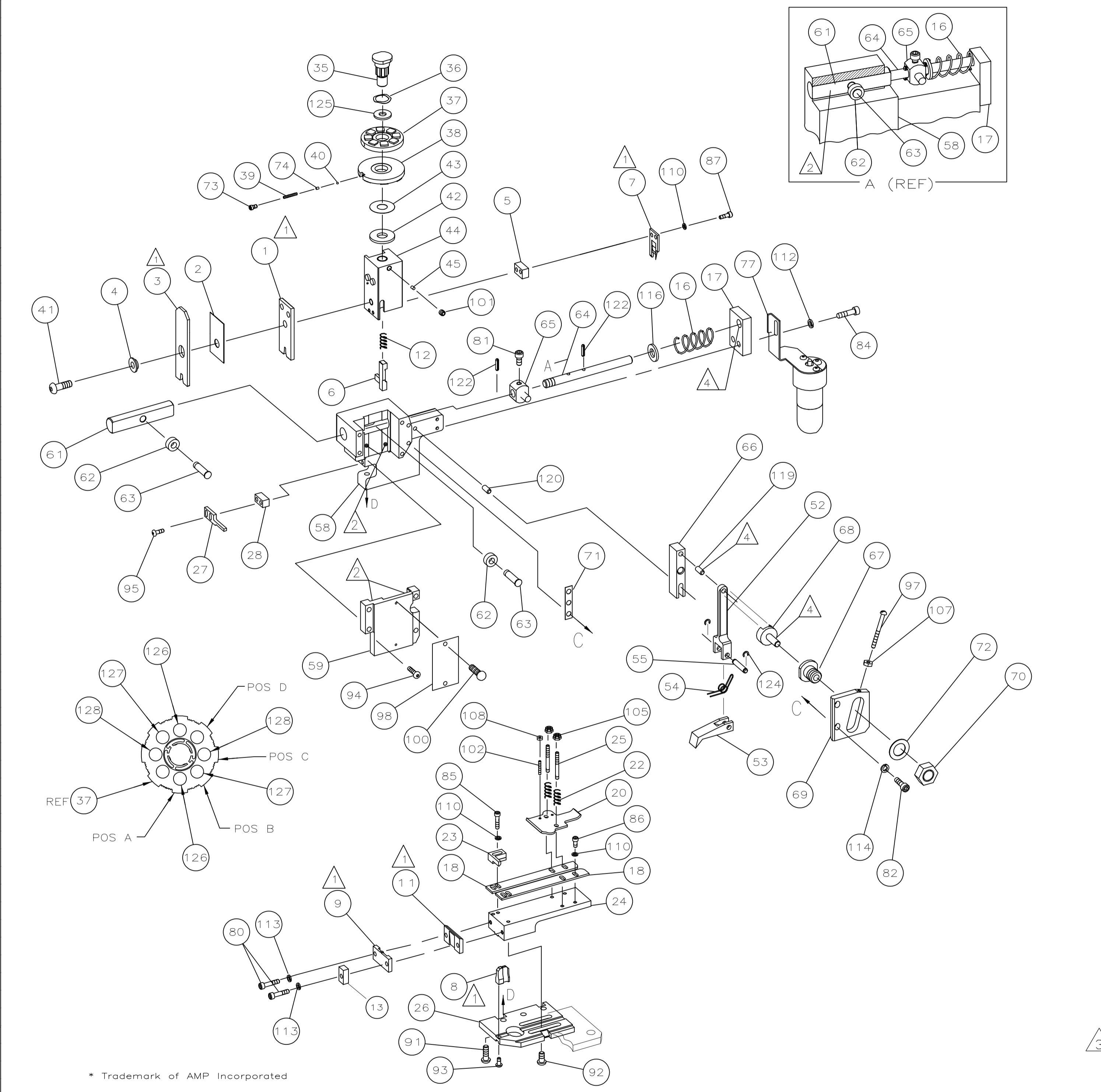

QTY	REQD	PER	ASSY	PART NO	DESCRIPTION	ITEM NO
2	2	2	-	3-354779-0	PIN, WIRE DISC (.3140)C	129
2	2	2	-	2-354779-4	PIN, WIRE DISC (.3110)B	128
2	2	2	-	1-354779-4	PIN, WIRE DISC (.3060)A	126
1	1	1	-	986950-1	WASHER, FLAT PRECISION	125
REF	REF	REF	-	21045-3	RING, RET "C" (Ø.187)FD PIN	124
REF	REF	REF	-	5-21028-1	PIN, STD SPRING (Ø.12)FD ADJ ROD	123
REF	REF	REF	-	1-21030-7	PIN, DOWEL (Ø.187x1.50)HSG	122
REF	REF	REF	-	1-21030-1	PIN, DOWEL (Ø.187x.50)LEVER	121
REF	REF	REF	-	21899-4	WASHER, FLAT (Ø5/16)SCR ADJ	120
REF	REF	REF	-	21024-5	WASHER, LOCK (NO.10)FD ADJ PL	119
2	2	2	-	21024-5	WASHER, LOCK (NO.10)SHEAR PL	118
REF	REF	REF	-	21024-5	WASHER, LOCK (NO.10)FD ROD GDE	117
7	7	7	-	21024-4	WASHER, LOCK (NO.8)SHEAR BL	116
2	2	2	-	21018-4	NUT, HEX (4-40)DRAG	115
REF	REF	REF	-	21018-5	NUT, HEX (6-32)FD ADJ PL	114
2	2	2	-	21022-2	NUT, HEX SL (8-32)DRAG STUD	113
2	2	2	-	2-21006-6	SCR, SKT SET (4-40x.62)DRAG	112
1	1	1	-	21009-2	SCR, SKT SET (1/4-20x.25)RAM	111
2	2	2	-	21017-2	SCR, DRIVE (#2x.19)ID PLATE	110
1	1	1	-	1-21002-7	SCR, BHC (6-32x.38)CAM	109
1	1	1	-	461264-1	PLATE, IDENTIFICATION	108
REF	REF	REF	-	6-23715-5	SCR, PAN HD (6-32x1.50)FEED ADJ	107
2	2	2	-	2-21002-2	SCR, BHC (8-32x.50)STRIPPER	106
REF	REF	REF	-	2-21002-9	SCR, BHC (10-32x.75)HSG CAP	105
1	1	1	-	22733-8	SCR, BHC (8-32x.38 LW)ANVIL	104
4	4	4	-	3-21002-3	SCR, BHC (1/4-20x.50)ST GD PL	103
REF	REF	REF	-	2-22733-8	SCR, BHC (1/4-20x.62)BASE PL	102
2	2	2	-	2-21000-6	SCR, SHC (8-32x.38)SLUG BLADE	101
3	3	3	-	7-21000-4	SCR, SHC (8-32x.31)STRIP GUIDE	100
2	2	2	-	2-21000-8	SCR, SHC (8-32x.62)R STRIP GUIDE	99
REF	REF	REF	-	3-21000-7	SCR, SKT CAP (10-32x.75)FD GDE	98
REF	REF	REF	-	3-21000-6	SCR, SKT CAP (10-32x.62)FD ADJ P	97
REF	REF	REF	-	3-21000-4	SCR, SKT CAP (10-32x.38)PIVOT BL	96
2	2	2	-	3-21000-8	SCR, SKT CAP (10-32x.88)SH PL	95
-	REF	-	-	455745-1	GUARD, WINDOW	94
REF	-	-	-	679532-1	INSERT, GUARD	93
-	1	-	-	465184-9	LUBRICATOR ASSY	92
1	1	1	-	690603-1	SPRING, ASSIST	91
1	1	1	-	23030-1	SCR, SKT CAP (6-32x.25)CP DSC	90
REF	REF	REF	-	458109-1	WASHER, FLAT (SPECIAL)	89
REF	REF	REF	-	690517-1	SPACER	88
-3	-2	-1	U/M			87

REF	REF	REF	REF	REF	DESCRIPTION	ITEM NO
REF	REF	REF	-	22594-8	NUT, HEX	70
REF	REF	REF	-	240628-1	PLATE, ADJ	69
REF	REF	REF	-	240626-1	SHAFT, PIVOT	68
REF	REF	REF	-	240633-1	BUSHING	67
REF	REF	REF	-	455680-1	LEVER, INTERMEDIATE	66
REF	REF	REF	-	240629-1	BLOCK, PIVOT	65
REF	REF	REF	-	240632-2	SCR, ADJ	64
REF	REF	REF	-	240659-3	PIN, CAM ROLLER	63
REF	REF	REF	-	240658-1	CAM, ROLLER	62
REF	REF	REF	-	454398-1	ROD, FEED	61
REF	REF	REF	-	454220-1	CAP, RAM	60
REF	REF	REF	-	453736-1	HOUSING	59
REF	REF	REF	-	240624-1	PIN, FEED FINGER	58
REF	REF	REF	-	691499-1	SPRING, FEED FINGER	57
REF	REF	REF	-	240635-1	FINGER, FEED	56
REF	REF	REF	-	240634-1	LEVER, TERMINAL	55
1	-	-	-	690602-6	CAM, PRE-FEED 1 5/8 ST	54
-	1	-	-	690602-5	CAM, PRE-FEED 1 1/8 ST	53
-	-	1	-	690501-4	CAM, POST-FEED 1 5/8 ST	52
1	1	1	-	690191-1	PLUG, NYLON	51
1	1	1	-	455674-1	RAM	50
1	1	1	-	690125-1	WASHER, LAMINATED	49
1	1	1	-	690124-1	WASHER, RAM	48
1	1	1	-	7-21002-9	BOLT, CRIMPER (5/16-24x1.00)	47
1	1	1	-	23241-6	BALL, STEEL	46
1	1	1	-	690170-1	SPRING, COMPRESSION	45
1	1	1	-	690142-1	DISC, INSULATION	44
1	1	1	-	354777-1	WIRE DISC, PLASTIC	43
1	1	1	-	22480-5	WASHER, SPRING	42
1	1	1	-	690212-1	POST, RAM	41
1	1	1	-	458980-1	APPLICATOR, BASIC (SUB ASSY)	40
1	1	1	-	3-690451-2	SPACER, STRIPPER	39
REF	REF	REF	-	240639-1	STRIPPER	38
REF	REF	REF	-	455676-1	PLATE, BASE	37
2	2	2	-	22354-8	DRAG, STUD	36
1	1	1	-	455678-1	PLATE, STRIP GUIDE	35
1	1	1	-	240825-2	PLATE, STRIP HOLD DOWN	34
2	2	2	-	4-22281-1	SPRING, DRAG	33
1	1	1	-	454177-1	DRAG, STOCK	32
2	2	2	-	454204-1	GUIDE, STRIP (FRONT)	31
REF	REF	REF	-	454178-1	GUIDE, FEED ROD	30
REF	REF	REF	-	4-22284-9	SPRING, FEED RETURN	29
1	1	1	-	1-690481-4	SPACER, HOLD DOWN	28
1	1	1	-	23846-1	SPRING, HOLD DOWN	27
1	1	1	-	240644-1	PLATE, REAR SHEAR	26
1	1	1	-	690482-6	PLATE, FRONT SHEAR	25
1	1	1	-	240655-6	ANVIL	24
1	1	1	-	690474-6	BLADE, SLUG	23
1	1	1	-	2-455892-2	HOLD DOWN, TERMINAL	22
1	1	1	-	2-240641-1	SPACER, SLUG BLADE	21
1	1	1	-	238009-1	SPACER, BLOCK CRIMPER	20
1	1	1	-	3-456135-7	CRIMPER, INSULATION	19
1	1	1	-	455888-1	SPACER, CRIMPER	18
1	1	1	-	3-456404-1	CRIMPER, WIRE	17
-3	-2	-1	U/M			16

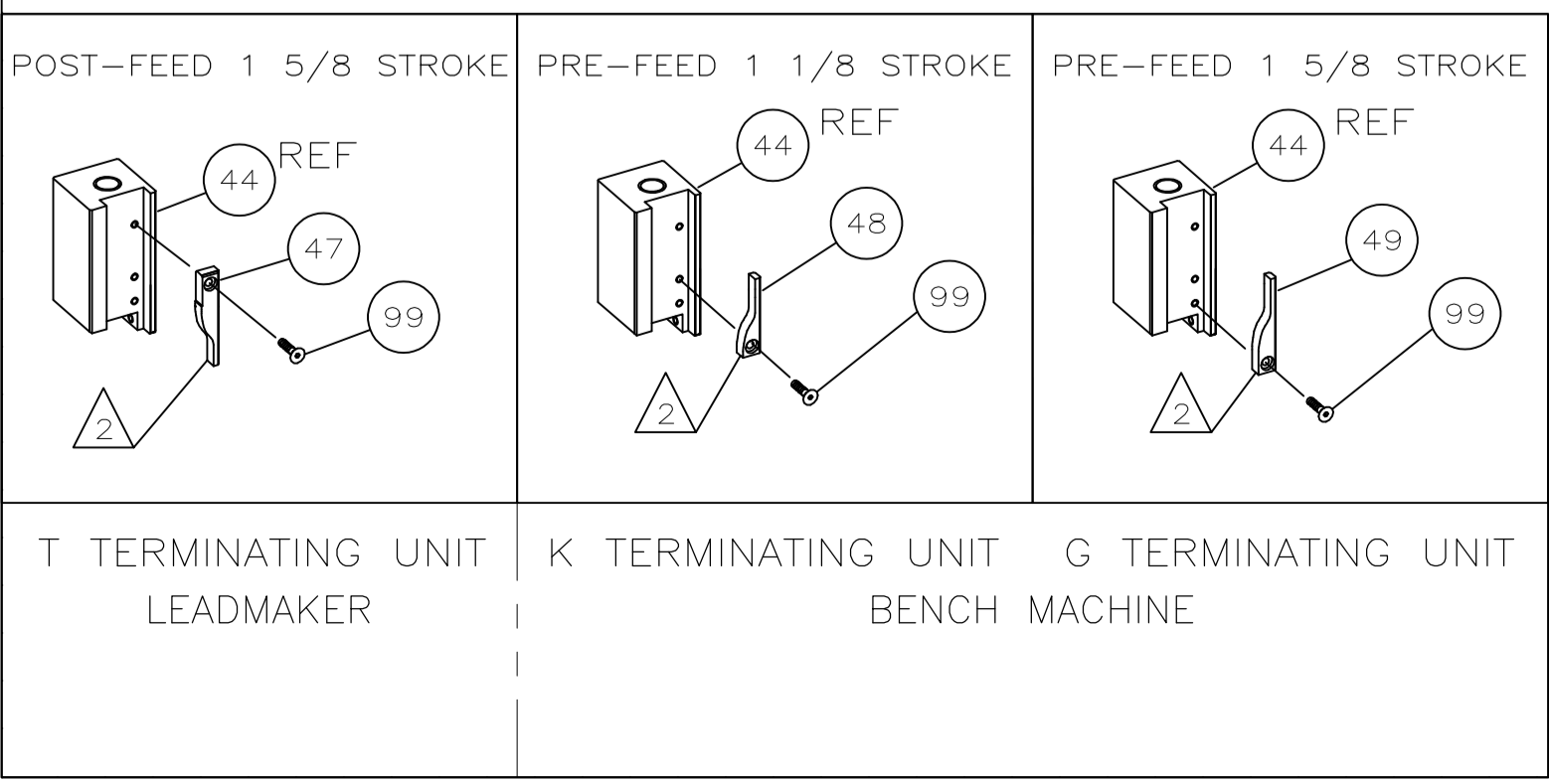

- 1 RECOMMENDED SPARE PARTS.
- 2 GREASE LIGHTLY.
- 3 GUARD MUST BE IN PLACE WHEN OPERATING APPLICATOR IN A BENCH MACHINE.
- 4 LUBRICATE DAILY USING NO. 20 MACHINE OIL.
- 5 ITEMS WITH QTY OF REF SPECIFIED (EXCEPT ITEMS 78 AND 79) ARE USED ON ITEM 32.
- 6 STRIP GUIDE & CRIMP HEIGHT ADJUSTMENT REQUIRED TO CONVERT FROM GROUP I TO GROUP II & VISE VERSA.
- 7 LUBRICATION REQUIRED WITH SILVER PLATED TERMINALS.

THIS DRAWING IS A CONTROLLED DOCUMENT.

APPROVED: E. KRISMAN 3/8/94

DESIGNED: R. O. WILSON 2/22/94

DRIVEN: C. FRISMAN 3/8/94

PRODUCT SPEC: END FEED HDM APPLICATOR

APPLICATION SPEC: -

WEIGHT: -

CUSTOMER DRAWING: A1 00779

SCALE: -

SHEET: 1 of 1

REV: J1

TYCO ELECTRONICS CORPORATION
HARRISBURG, PA 17105-3608