

Ultra-low power digital PDM XENSIV™ MEMS microphone

Features

- Ultra-low current consumption in high performance mode (520µA)
- Low current consumption in low power mode (180µA)
- Signal to noise ratio (SNR) of 69dB(A)
- Acoustic overload point at 128dB SPL
- Flat frequency response with a low frequency roll-off at 30Hz
- Component level IP57 water and dust resistant
- Package dimensions: 3.5mm x 2.65mm x 0.98mm
- Enhanced RF shielding
- Digital PDM output
- Bottom port

Potential applications

- Active Noise Cancellation (ANC) headphones and earphones
- Smartphones and mobile devices
- High quality audio capturing
 - Laptops and tablets
 - Conference systems
 - Cameras and camcorders
- Devices with Voice User Interface (VUI)
 - Smart speakers
 - Home automation
 - IOT devices
- Industrial or home monitoring with audio pattern detection

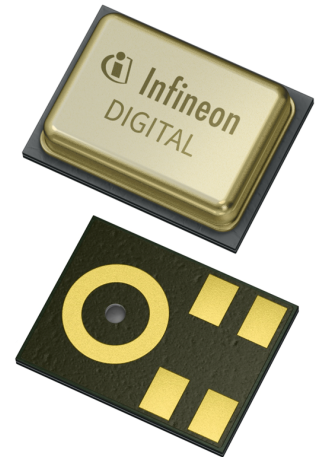

RoHS



Green



Halogen-free

Product validation

Technology qualified for industrial applications.

Ready for validation in industrial applications according to the relevant tests of IEC 60747 and 60749 or alternatively JEDEC47/20/22.

Description

Discover the IM69D128S – an ultra-low power digital XENSIV™ MEMS microphone, designed for applications which require high SNR (low self-noise), long battery life, and environmental robustness in a small package.

Great signal-to-noise ratio (SNR) of 69dB(A) enables crystal clear audio experience without compromising on battery life.

Enabled by a revolutionary digital microphone ASIC, the IM69D128S sets a new benchmark by cutting current consumption to 520µA – almost the half of what models with similar performance on the market can offer.

Additionally, IM69D128S masters the art of switching between different power & performance profiles without any audible artifacts.

IM69D128S is based on Infineon's Sealed Dual Membrane MEMS technology which delivers high ingress protection (IP57) at a microphone level.

Type	Package	Marking
IM69D128SV01	PG-TLGA-5-2	I69D18

Table of contents

	Features	1
	Potential applications	1
	Product validation	1
	Description	1
	Table of contents	2
1	Block diagram	3
2	Typical performance characteristics	4
3	Acoustic characteristics	6
4	Electrical characteristics and parameters	7
4.1	Absolute maximum ratings	7
4.2	Electrical parameters	7
4.3	Electrical characteristics	8
4.4	Audio DC offset	9
4.5	Stereo PDM configuration	10
5	Package information	11
6	Footprint and stencil recommendation	12
7	Packing information	13
8	Reflow soldering and board assembly	14
9	Reliability specifications	16
9.1	Environmental robustness	17
	Revision history	18
	Disclaimer	19

1 Block diagram

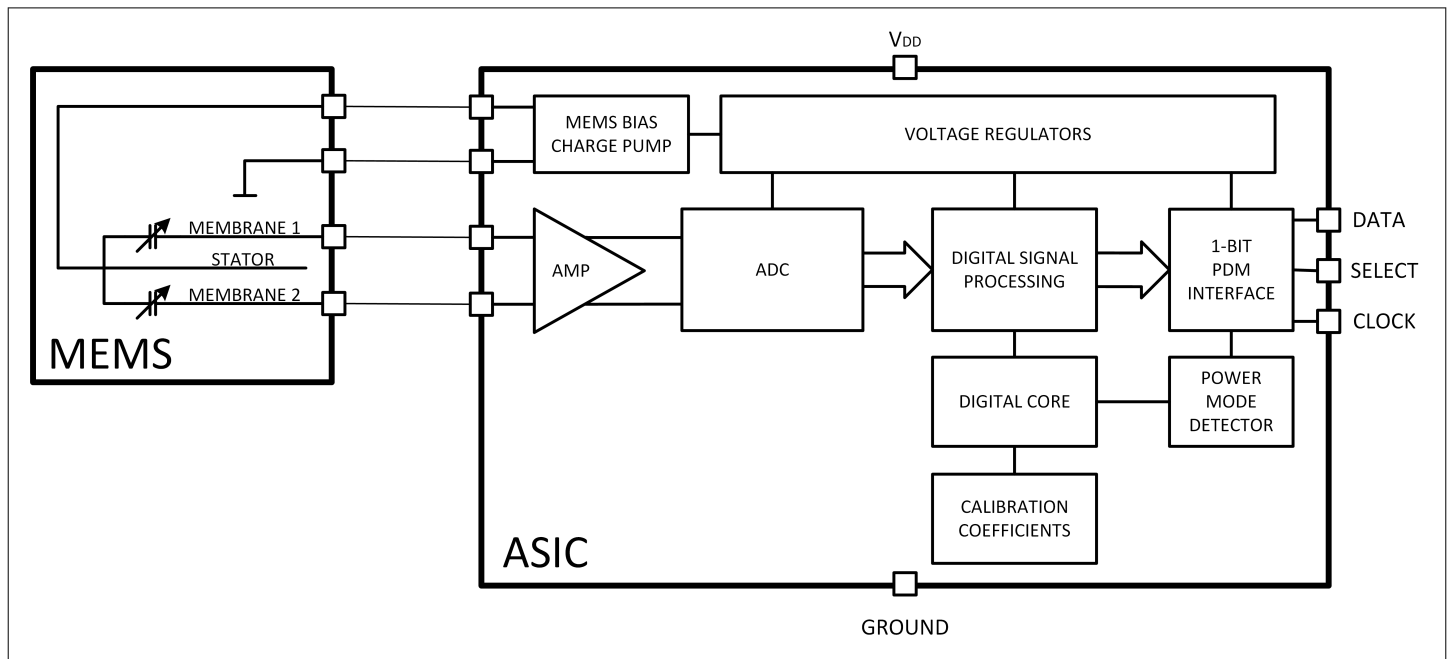

Figure 1 Block diagram

2 Typical performance characteristics

2 Typical performance characteristics

Test conditions: $V_{DD} = 1.8V$, $f_{CLK} = 3.072MHz$, $T_A = 25^\circ C$, unless otherwise specified.

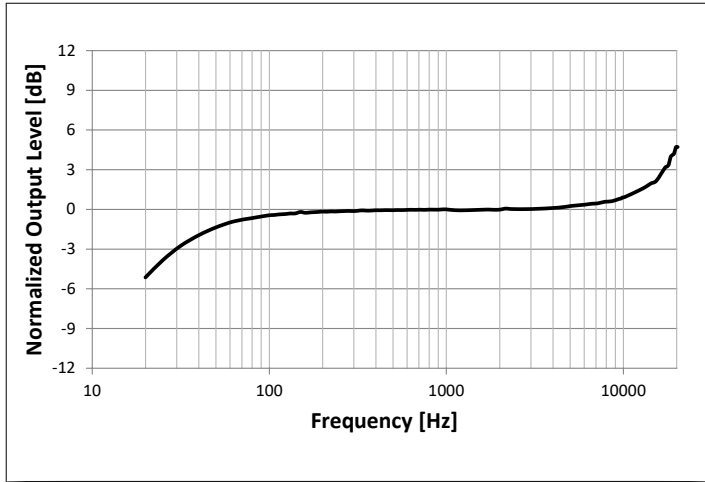

Figure 2 Typical amplitude response

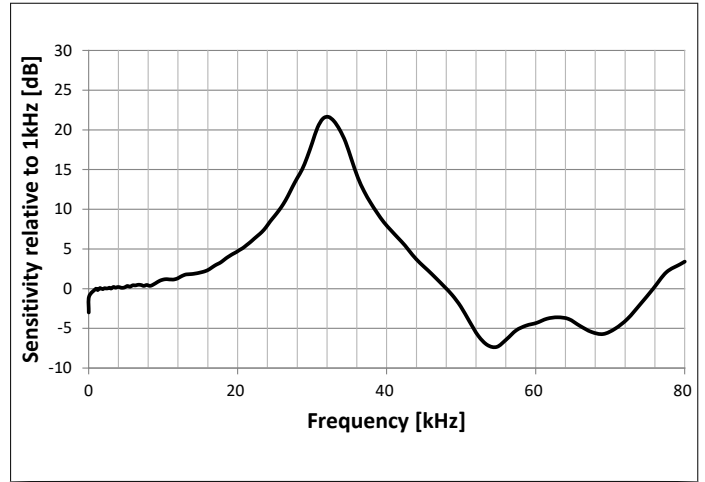

Figure 3 Typical ultrasonic response

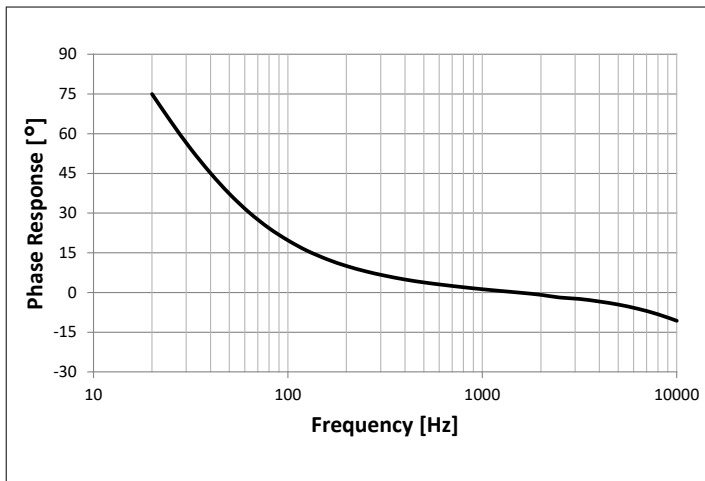

Figure 4 Typical phase response

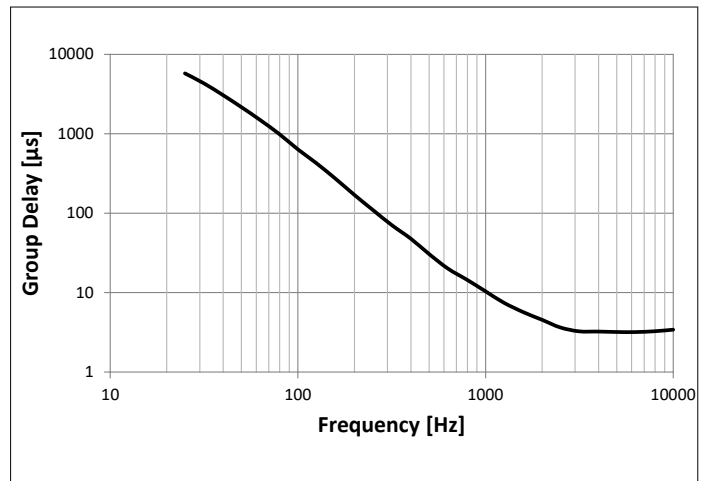

Figure 5 Typical group delay

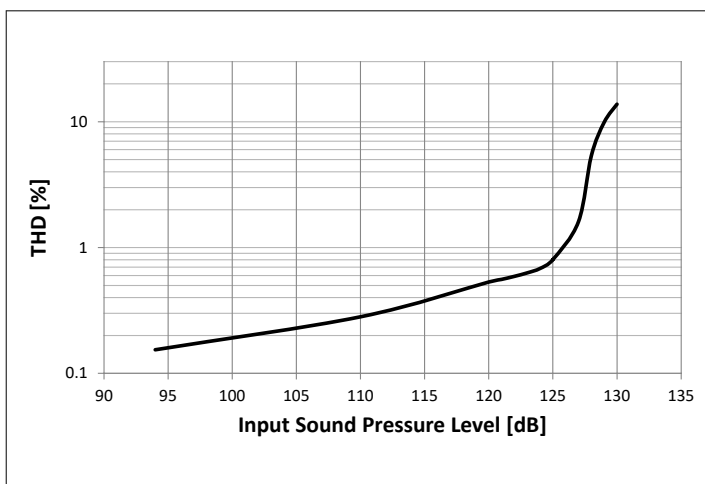

Figure 6 Typical THD vs SPL

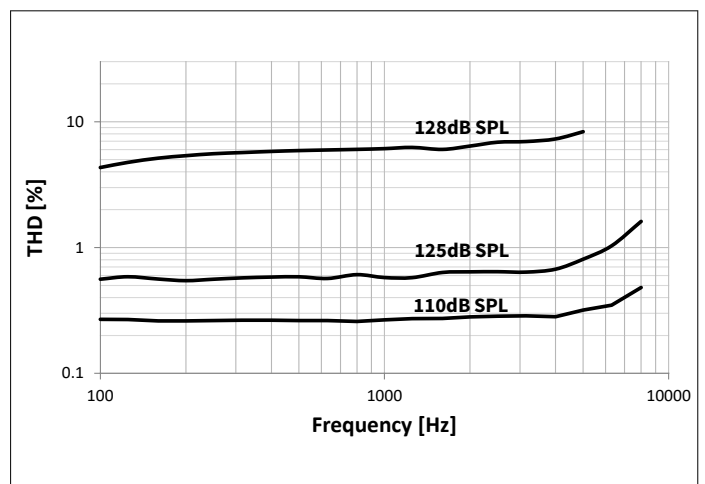

Figure 7 Typical THD vs frequency

2 Typical performance characteristics

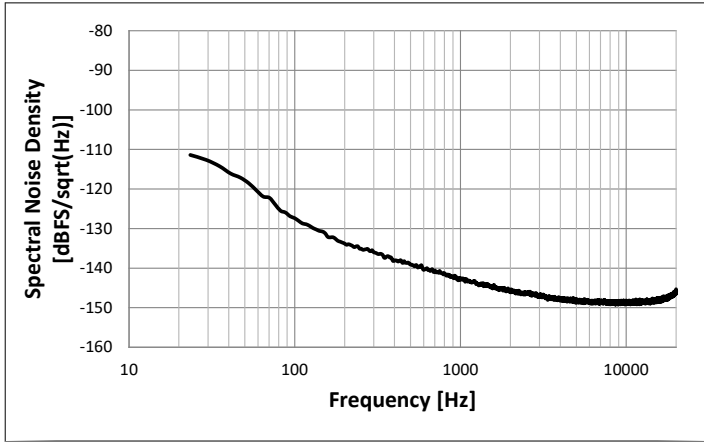

Figure 8 Typical noise floor (unweighted)

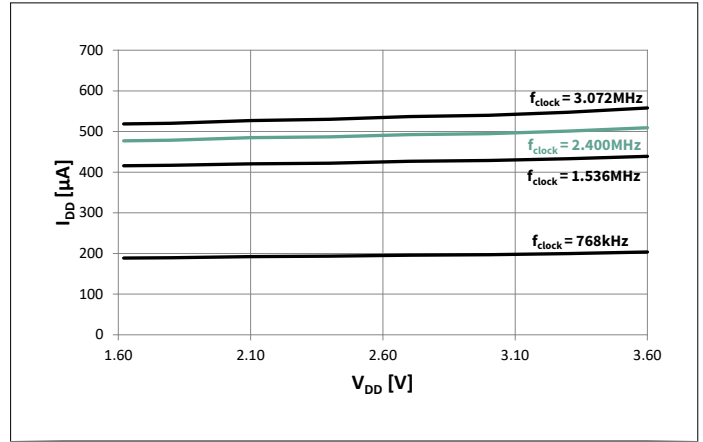

Figure 9 Typical I_{DD} vs V_{DD}

3 Acoustic characteristics

Test conditions (unless otherwise specified in the table): $V_{DD} = 1.8V$, $f_{CLK} = 3.072MHz$, $OSR=64$, $T_A = 25^{\circ}C$, 55% R.H., audio bandwidth 20Hz to 20kHz, select pin grounded, no load on DATA, $T_{edge} = 9ns$

Table 1 Acoustic specifications

Parameter	Symbol	Values			Unit	Note or Test Condition	
		Min.	Typ.	Max.			
Sensitivity	S	-38	-37	-36	dBFS	1kHz, 94 dB SPL, all operating modes	
Low Frequency Roll-off	LFRO		30		Hz	-3dB relative to 1kHz	
Resonant Frequency Peak			30		kHz		
Signal to Noise Ratio	$F_{clock} = 768kHz$	SNR		66		dB(A)	20Hz to 8kHz bandwidth, OSR: 48, A-Weighted
	$F_{clock} = 1.536MHz$			67.5			
	$F_{clock} = 2.4MHz$			68			
	$F_{clock} = 3.072MHz$			69			
Total Harmonic Distortion	94dB SPL	THD			0.3	%	Measuring 2nd to 5th harmonics; 1kHz. S=typ, all operating modes
	125dB SPL			1.0			
Acoustic Overload Point	10% THD	AOP		128		dB SPL	Measuring 2nd to 5th harmonics; 1kHz. S=typ, all operating modes
Group Delay	250Hz			120		μs	
	600Hz			20			
	1kHz			10			
	4kHz			3.5			
Phase Response	75Hz			25		°	
	1kHz			1			
	4kHz			-4			
Directivity			Omnidirectional				
Polarity		Positive pressure increases density of 1's, negative pressure decreases density of 1's in data output					

4 Electrical characteristics and parameters

4.1 Absolute maximum ratings

Stresses exceeding the listed maximum ratings may affect device reliability or cause permanent device damage. Functional device operation at these conditions is not guaranteed.

Table 2 Absolute maximum ratings

Parameter	Symbol	Values		Unit	Note / Test Condition
		Min.	Max.		
Voltage on any Pin	V_{max}		3.6	V	
Storage Temperature	T_S	-40	125	°C	
Ambient Temperature	T_A	-40	85	°C	

4.2 Electrical parameters

Table 3 Electrical parameters and digital interface input

Parameter	Symbol	Values			Unit	Note / Test Condition	
		Min.	Typ.	Max.			
Supply Voltage	V_{DD}	1.62	1.8	3.6	V	1)	
Clock Frequency Range	Standby Mode	f_{clock}			350	kHz	2)
	Low Power Mode		380	768	1020	kHz	
	Normal Mode		1.2	3.072	3.3	MHz	
V_{DD} Ramp-up Time				50	ms	Time until $V_{DD} \geq V_{DD_min}$	
Input Logic Low Level	V_{IL}			$0.3 \times V_{DD}$	V		
Input Logic High Level	V_{IH}	$0.7 \times V_{DD}$			V		
Clock Rise/Fall Time				13	ns	10% to 90%	
Clock Duty Cycle		45		55	%		
Output Load Capacitance on DATA	C_{load}			100	pF		

¹ A 1 μ F bypass capacitor shall be placed close to the microphone V_{DD} pad to ensure best SNR performance.

² Data pad is high impedance in standby mode.

4.3 Electrical characteristics

Test conditions (unless otherwise specified in the table): $V_{DD} = 1.8V$, $T_A = 25^\circ C$, 55% R.H.

Table 4 General electrical characteristics

Parameter		Symbol	Values			Unit	Note / Test Condition	
			Min.	Typ.	Max.			
Current Consumption	Clock Off Mode	I_{clock_off}			1	μA	CLOCK pulled low	
	Standby Mode	$I_{standby}$		25	50		No load on DATA	
	$F_{clock} = 768kHz$	I_{DD}		180	250		<5pF load on DATA	
	$F_{clock} = 1.536MHz$			420				
	$F_{clock} = 2.4MHz$			480				
	$F_{clock} = 3.072MHz$			520	650			
Short Circuit Current			1		20	mA	Grounded DATA pin	
Power Supply Rejection		PSR_{1k_NM}		-80		dBFS	100mV _{pp} sine wave on V_{DD} swept from 200Hz to 20kHz.	
		PSR_{217_NM}		-86		dBFS(A)	100mV _{rms} , 217Hz square wave on V_{DD} . A-weighted.	
Startup Time	$\pm 0.5dB$ sensitivity accuracy				20	ms	Time to start up in any operating modes after V_{DD_min} and CLOCK have been applied. ³⁾	
	$\pm 0.2dB$ sensitivity accuracy				50			
Mode Switch Time	$\pm 0.5dB$ sensitivity accuracy				20	ms	Time to switch between operating modes. V_{DD} remains on during the mode switch. ³⁾	
	$\pm 0.2dB$ sensitivity accuracy				50			
Output Logic Low Level		V_{OL}			$0.2 \times V_{DD}$	V		
Output Logic High Level		V_{OH}	$0.8 \times V_{DD}$					
Delay Time for DATA Driven		t_{DD}	40		80	ns	Delay time from CLOCK edge ($0.5 \times V_{DD}$) to DATA driven.	
Delay Time for DATA High-Z ⁴⁾		t_{HZ}	5		30	ns	Delay time from CLOCK edge ($0.5 \times V_{DD}$) to DATA high impedance state	
Delay Time for DATA Valid ⁵⁾		t_{DV}			100	ns	Delay time from CLOCK edge ($0.5 \times V_{DD}$) to DATA valid ($< 0.3 \times V_{DD}$ or $> 0.7 \times V_{DD}$)	
Power-on behaviour		Idle tone is output over PDM within 3ms of applying V_{DD} and f_{clock} , remains until a valid microphone signal is available. Idle tone consists of alternating 1s and 0s, representing a zero input signal.						

³⁾ Verified at typical PDM clock frequencies for each power mode.

⁴⁾ t_{hold} is dependent on C_{load}

⁵⁾ Load on data: $C_{load} = 100pF$, $R_{load} = 100k\Omega$

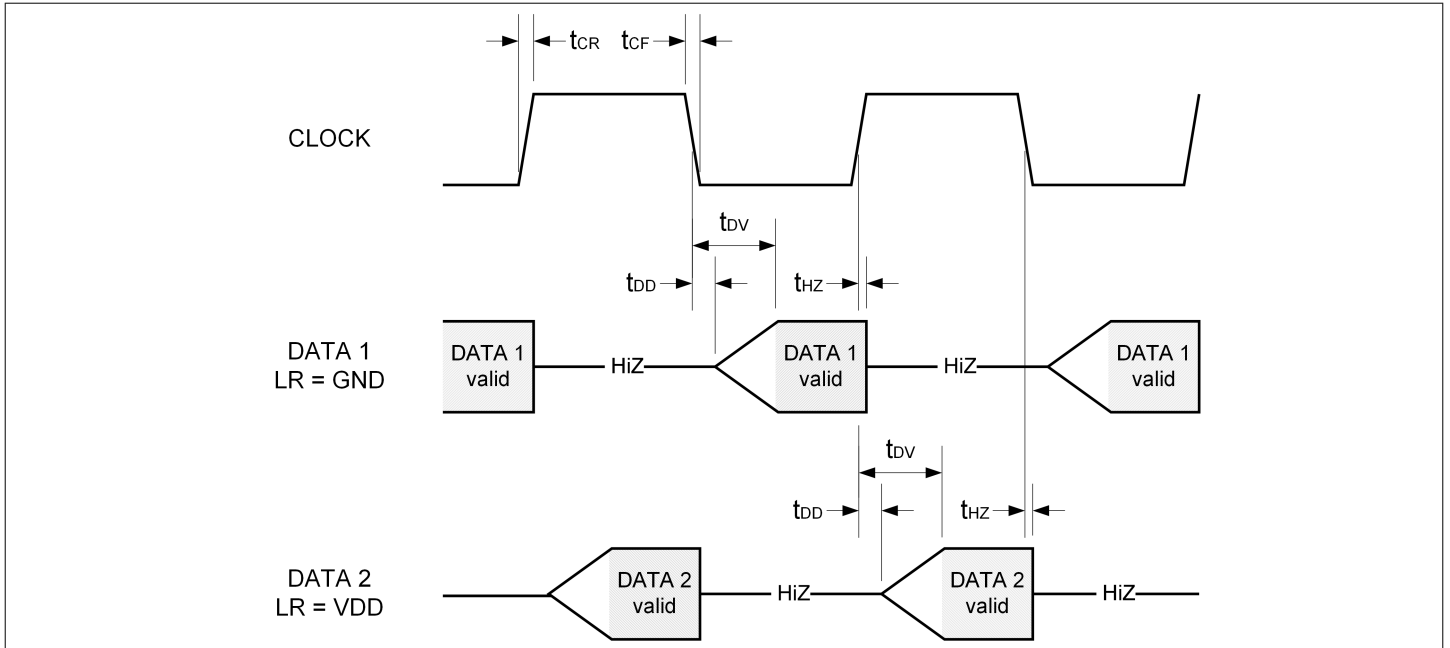

Figure 10 Timing diagram

4.4 Audio DC offset

The DC output level encoded in the DC bit stream is determined by the L/R state on startup. In each case the DC output level is stable over time and does not vary with input signal level.

Table 5 DC output level using L/R pin

LR state	DC output level (typical)	Unit
LR = GND	-80	dBFS
LR = VDD	-40	dBFS

4.5 Stereo PDM configuration

The IM69D128S is designed to function in circuits with one or two microphones on the PDM bus. When two microphones are connected, data is transmitted alternately according to the L/R pin status of each microphone. When two microphones are connected to a shared PDM bus, the power modes of both microphones will be the same as both are controlled by the same PDM clock. The performance is unchanged relative to a single microphone per bus configuration.

Table 6 PDM channel configuration using L/R pin.

Channel	Data driven	Data high-Z	L/R connection
DATA1	Falling clock edge	Rising clock edge	GND
DATA2	Rising clock edge	Falling clock edge	V _{DD}

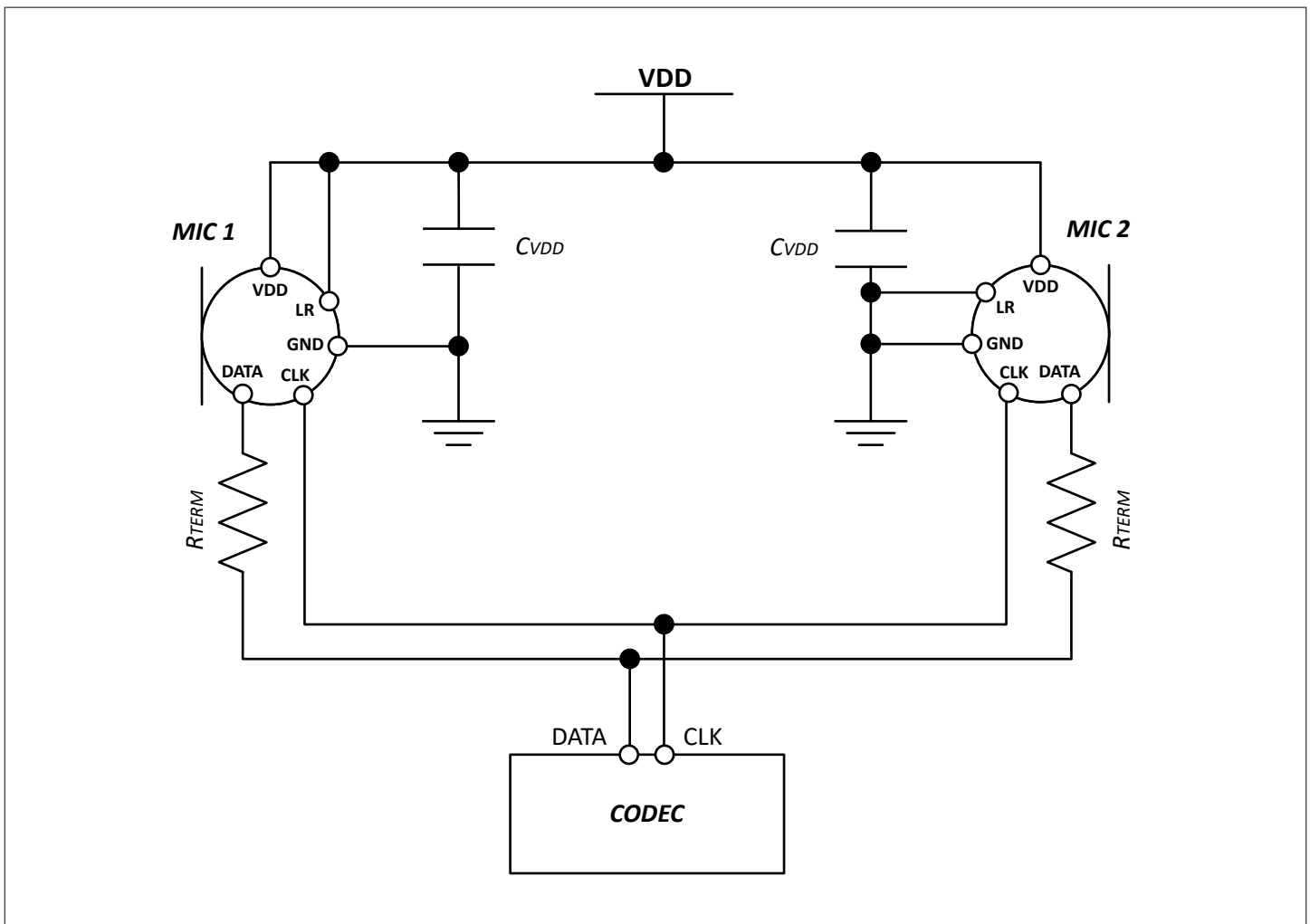

Figure 11 Typical stereo mode configuration

Note: For best performance it is strongly recommended to place a 100nF ($C_{VDD_typical}$) capacitor between V_{DD} and ground. The capacitor should be placed as close to V_{DD} as possible. A termination resistor (R_{TERM}) of about 100Ω may be added to reduce the ringing and overshoot on the output signal.

5 Package information

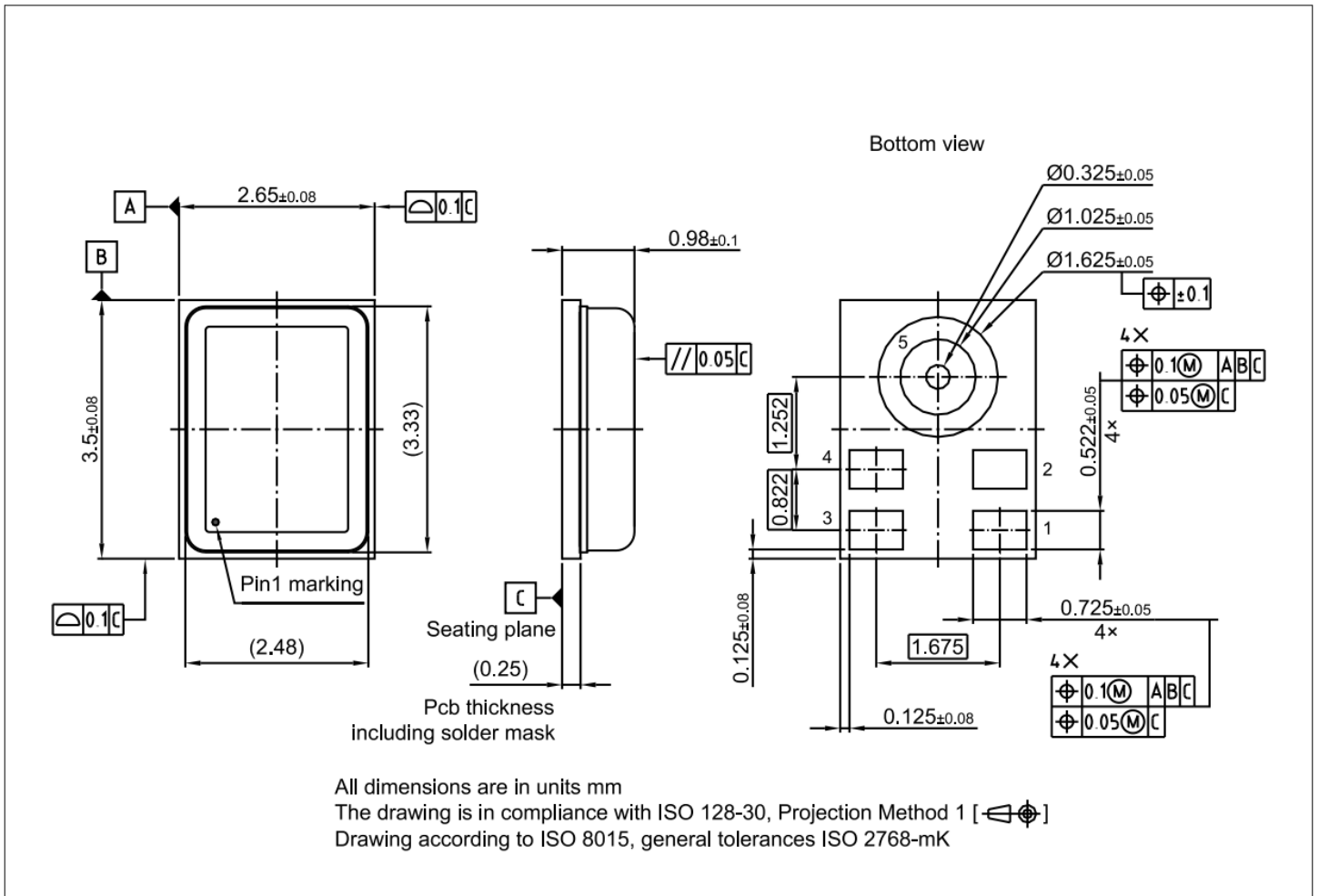

Figure 12 IM69D128SV01 package drawing

Table 7 IM69D128SV01 pin configuration

Pin Number	Name	Description
1	V _{DD}	Power supply
2	CLOCK	PDM clock input
3	DATA	PDM data output
4	LR select	PDM left/right select
5	GND	Ground

6 Footprint and stencil recommendation

The acoustic port hole diameter in the PCB should be larger than the acoustic port hole diameter of the MEMS microphone to ensure optimal performance. A PCB sound port size of diameter 0.6 mm is recommended.

The board pad and stencil aperture recommendations shown in [Figure 13](#) are based on Solder Mask Defined (SMD) pads. The specific design rules of the board manufacturer should be considered for individual design optimizations or adaptations.

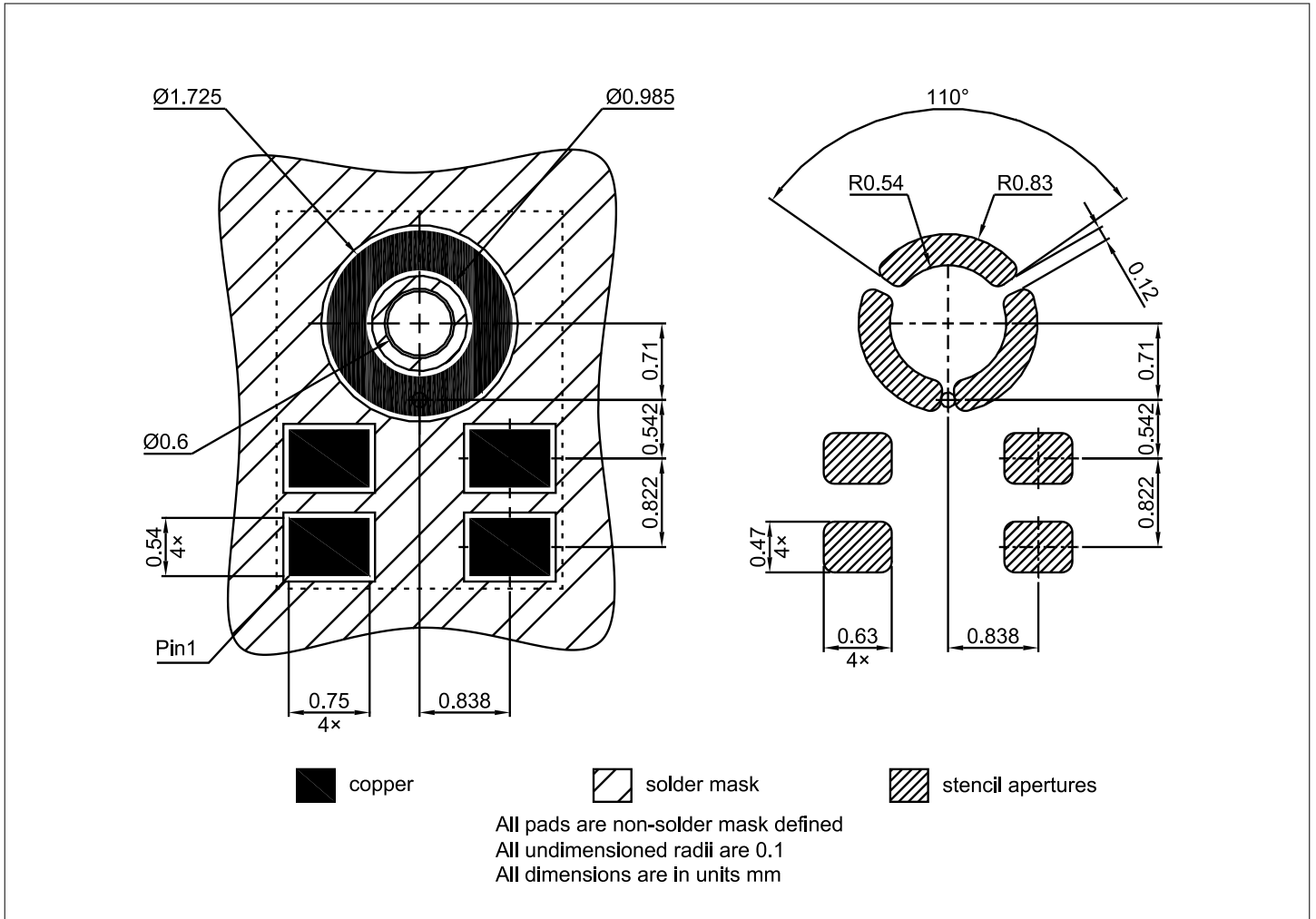

Figure 13 Footprint and stencil recommendation

7 Packing information

For shipping and assembly the Infineon microphones are packed in product specific tape-and-reel carriers. A detailed drawing of the carrier can be seen in [Figure 14](#)

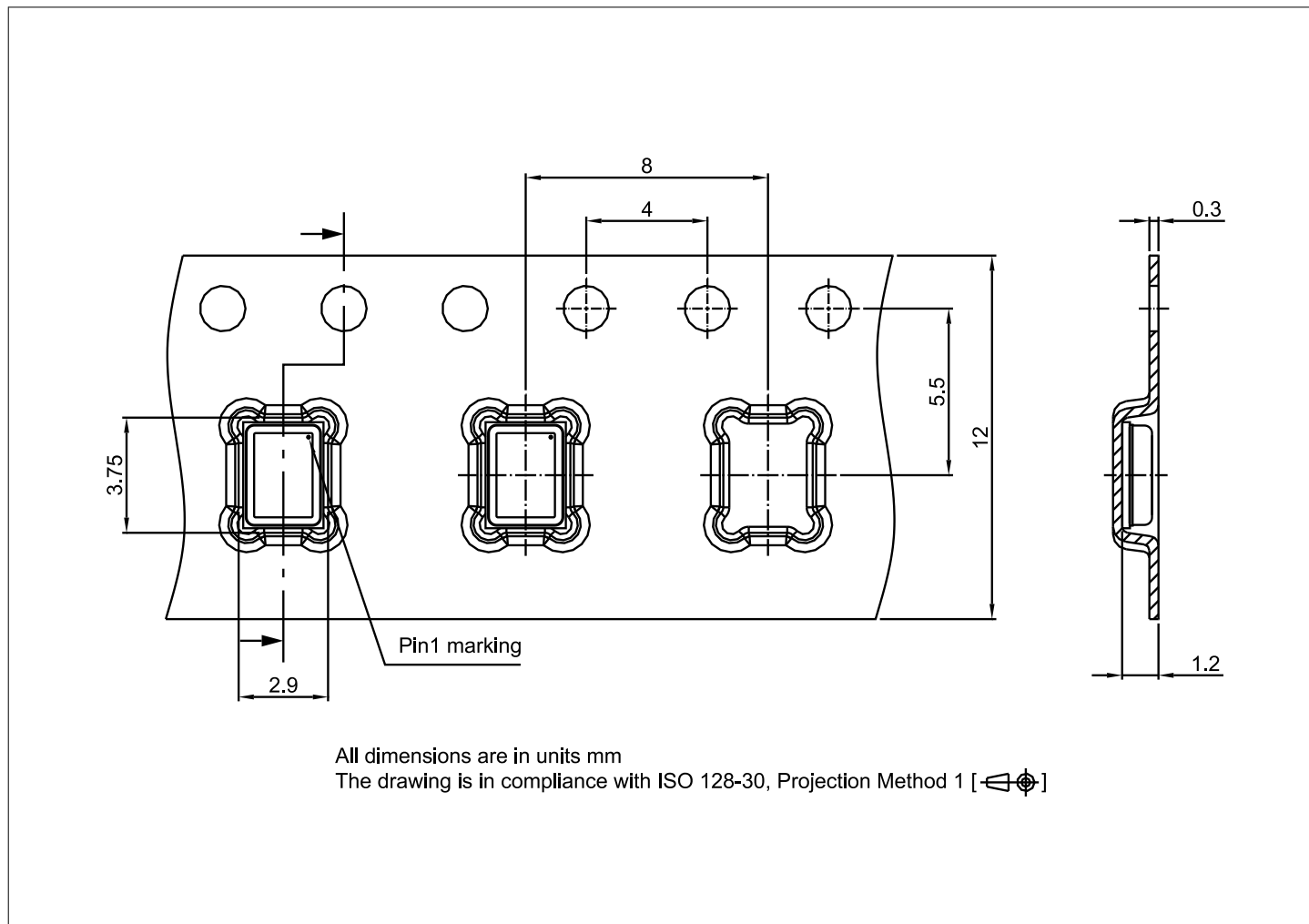

Figure 14 IM69D128SV01 tape and reel packing information

Table 8 IM69D128SV01 packaging information

Product	Type code	Reel diameter	Quantity per reel
IM69D128SV01	I69D18	13"	5000

8 Reflow soldering and board assembly

Infineon MEMS microphones are qualified in accordance with the IPC/JEDEC J-STD-020D-01. The moisture sensitivity level of MEMS microphones is rated as MSL1. For PCB assembly of the MEMS microphone the widely used reflow soldering using a forced convection oven is recommended.

The soldering profile should be in accordance with the recommendations of the solder paste manufacturer to reach an optimal solder joint quality. The reflow profile shown in [Figure 15](#) is recommended for board manufacturing with Infineon MEMS microphones.

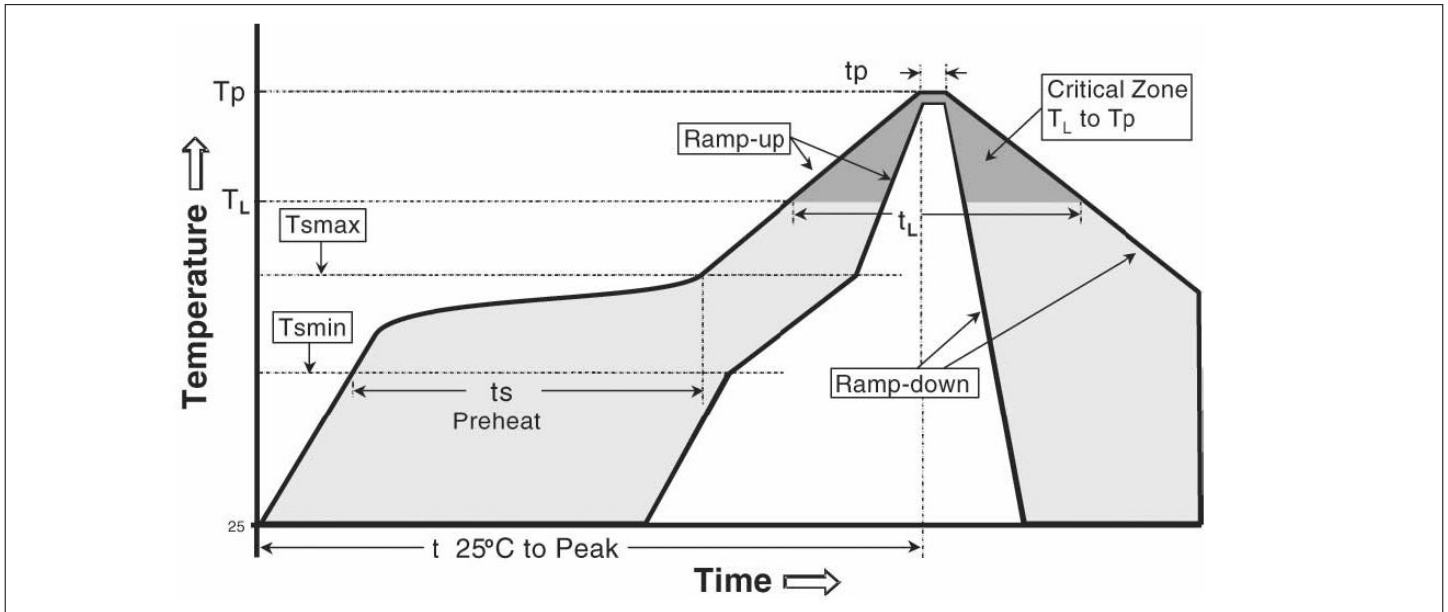

Figure 15 Recommended reflow profile

Table 9 Reflow profile limits

Profile feature	Pb-Free assembly	Sn-Pb Eutectic assembly
Temperature Min (T_{smin})	150 °C	100 °C
Temperature Max (T_{smax})	200 °C	150 °C
Time (T_{smin} to T_{smax}) (t_s)	60-120 seconds	60-120 seconds
Ramp-up rate (T_L to T_P)	3 °C/second max.	3 °C/second max.
Liquidous temperature (T_L)	217 °C	183 °C
Time (t_L) maintained above T_L	60-150 seconds	60-150 seconds
Peak Temperature (T_P)	260°C +0°C/-5°C	235°C +0°C/-5°C
Time within 5°C of actual peak temperature (t_p) ⁶⁾	20-40 seconds	10-30 seconds
Ramp-down rate	6 °C/second max.	6 °C/second max.
Time 25°C to peak temperature	8 minutes max.	6 minutes max.

Note: For further information please consult the 'General recommendation for assembly of Infineon packages' document which is available on the Infineon Technologies [web page](#)

⁶⁾ Tolerance for peak profile temperature (T_P) is defined as a supplier minimum and a user maximum

The MEMS microphones can be handled using industry standard pick and place equipment. Care should be taken to avoid damage to the microphone structure as follows:

- Do not pick the microphone with vacuum tools which make contact with the microphone acoustic port hole.
- The microphone acoustic port hole should not be exposed to vacuum, this can destroy or damage the MEMS.
- Do not blow air into the microphone acoustic port hole. If an air blow cleaning process is used, the port hole must be sealed to prevent particle contamination.
- It is recommended to perform the PCB assembly in a clean room environment in order to avoid microphone contamination.
- Air blow and ultrasonic cleaning procedures shall not be applied to MEMS Microphones. A no-clean paste is recommended for the assembly to avoid subsequent cleaning steps. The microphone MEMS can be severely damaged by cleaning substances.
- To prevent the blocking or partial blocking of the sound port during PCB assembly, it is recommended to cover the sound port with protective tape during PCB sawing or system assembly.
- Do not use excessive force to place the microphone on the PCB. The use of industry standard pick and place tools is recommended in order to limit the mechanical force exerted on the package.

9 Reliability specifications

The microphone sensitivity after stress must deviate by no more than 3dB from the initial value.

Table 10 Reliability specification

Test	Abbreviation	Test Condition	Standard
Low Temperature Operating Life	LTOL	T _a =-40°C, VDD=3.6V, 1000 hours	JESD22-A108
Low Temperature Storage Life	LTSL	T _a =-40°C, 1000 hours	JESD22-A119
High Temperature Operation Life	HTOL	T _a =+125°C, VDD=3.6V, 1000 hours	JESD22-A108
High Temperature Storage Life	HTSL	T _a =+125°C, 1000 hours	JESD22-A103
Temperature Cycling	PC + TC	Pre conditioning MSL-1	JESD22-A113
		1000 cycles, -40°C to +125°C, 30 minutes per cycle	JESD22-A104
Temperature Humidity Bias	PC + THB	Pre conditioning MSL-1	JESD22-A113
		T _a =+85°C, R.H = 85%, VDD=3.6V, 1000 hours	JESD22-A101
Vibration Test	VVF	20Hz to 2000Hz with a peak acceleration of 20g in X, Y, and Z for 4 minutes each, total 4 -cycles	IEC 60068-2-6
Mechanical Shock	MS	10000g/0.1msec direction ±x,y,z, 5 shocks in each direction, 5 shocks in total	IEC 60068-2-27
Reflow Solder ⁷⁾	RS	3 reflow cycles, peak temperature = +260°C	IPC-JEDEC J-STD-020D-01
Electrostatic Discharge -System Level Test	ESD - SLT	3 discharges of ±8kV direct contact to lid while V _{dd} is supplied according to the operational modes; (V _{dd} ground is separated from earth ground)	IEC-61000-4-2
Electrostatic Discharge - Human Body Model	ESD - HBM	1 pulse of ±2kV between all I/O pin combinations	JEDEC-JS001
Electrostatic Discharge - Charged Device Model	ESD - CDM	3 discharges of ±500V direct contact to I/O pins.	JEDEC JS-002

⁷⁾ The microphone sensitivity must deviate by no more than 1dB from the initial value after 3 reflow cycles.

9.1 Environmental robustness

Infineon's latest Sealed Dual Membrane MEMS technology delivers high ingress protection (IP57) at a microphone level. The sealed MEMS design prevents water or dust from entering between membrane and backplate, preventing mechanical blockage or electric leakage issues commonly observed in MEMS microphones. Microphones built with the Sealed Dual Membrane technology can be used to create IP68 devices, requiring only minimal mesh protection.

Table 11 Environmental robustness

Test Standard	Test Condition
IP5x dust resistance ⁸⁾	Arizona dust A4 coarse, vertical orientation, sound hole upwards, 10 cycles (15 minutes sedimentation, 6 sec blowing)
IPx7 water immersion ⁹⁾	Temporary immersion of 1 meters for 30 minutes. Microphone tested 2 hours after removal

⁸ The number "5" stands for the dust ingress rating or the capacity to withstand the effects of fine, abrasive dust particles.

⁹ The "7" specifies the higher water immersion rating.

Revision history

Document version	Date of release	Description of changes
v1.00	2023-01-05	Initial datasheet release
v1.01	2023-01-18	Corrected package information

Trademarks

All referenced product or service names and trademarks are the property of their respective owners.

Edition 2023-01-18

Published by

Infineon Technologies AG

81726 Munich, Germany

© 2023 Infineon Technologies AG

All Rights Reserved.

Do you have a question about any aspect of this document?

Email: erratum@infineon.com

Document reference

IFX-jrg1646838873068

Important notice

The information given in this document shall in no event be regarded as a guarantee of conditions or characteristics ("Beschaffheitsgarantie").

With respect to any examples, hints or any typical values stated herein and/or any information regarding the application of the product, Infineon Technologies hereby disclaims any and all warranties and liabilities of any kind, including without limitation warranties of non-infringement of intellectual property rights of any third party.

In addition, any information given in this document is subject to customer's compliance with its obligations stated in this document and any applicable legal requirements, norms and standards concerning customer's products and any use of the product of Infineon Technologies in customer's applications.

The data contained in this document is exclusively intended for technically trained staff. It is the responsibility of customer's technical departments to evaluate the suitability of the product for the intended application and the completeness of the product information given in this document with respect to such application.

Warnings

Due to technical requirements products may contain dangerous substances. For information on the types in question please contact your nearest Infineon Technologies office.

Except as otherwise explicitly approved by Infineon Technologies in a written document signed by authorized representatives of Infineon Technologies, Infineon Technologies' products may not be used in any applications where a failure of the product or any consequences of the use thereof can reasonably be expected to result in personal injury.