

| |
|--------------|
| PART NUMBER |
| 134-1000-038 |

| REV | ECO | DATE |
|-----|-----------------|-----------|
| 1 | INITIAL RELEASE | 04SEP2020 |
| | | |
| | | |

NOTES:

1. MATERIAL AND FINISH:

- 1.1 BODY: STAINLESS STEEL, PASSIVATED
- 1.2 CONTACT: BERYLLIUM COPPER, GOLD PLATE
- 1.3 INSULATOR: ULTEM 1000, AMBER

2. ELECTRICAL SPECIFICATIONS:

- 2.1 IMPEDANCE: 50 OHMS NOMINAL
- 2.2 FREQUENCY RANGE: DC~50 GHz
- 2.3 VSWR: 1.30 MAX
- 2.4 DIELECTRIC WITHSTANDING VOLTAGE: 250 VRMS MIN
- 2.5 INSULATION RESISTANCE: 3500 MEGOHM MIN
- 2.6 CONTACT RESISTANCE:
 - 2.6.1 CENTER CONTACT - 6.0 MILLIOHM MAX
 - 2.6.2 OUTER CONDUCTOR - 2.0 MILLIOHM MAX

3. MECHANICAL SPECIFICATIONS:

- 3.1 ENGAGE/DISENGAGE FORCE: 0.23 Nm MAX (2.4MM)
2.5 LBS MAX/4.5 LBS MAX (SMP3)
- 3.2 CONTACT RETENTION: 20 N MIN
- 3.3 DURABILITY: 500 CYCLES MIN (2.4MM)
100 CYCLES MIN (SMP3)

4. ENVIRONMENTAL:

- (MEETS OR EXCEEDS THE APPLICABLE PARAGRAPH OF MIL-PRF-39012)
- 4.1 THERMAL SHOCK: MIL-STD-202, METHOD 107, CONDITION B
- 4.2 OPERATING TEMPERATURE: -65°C TO 165°C
- 4.3 MOISTURE RESISTANCE: MIL-STD-202, METHOD 106
- 4.4 MECHANICAL SHOCK: MIL-STD-202, METHOD 213, CONDITION I
- 4.5 VIBRATION: MIL-STD-202, METHOD 204, CONDITION D

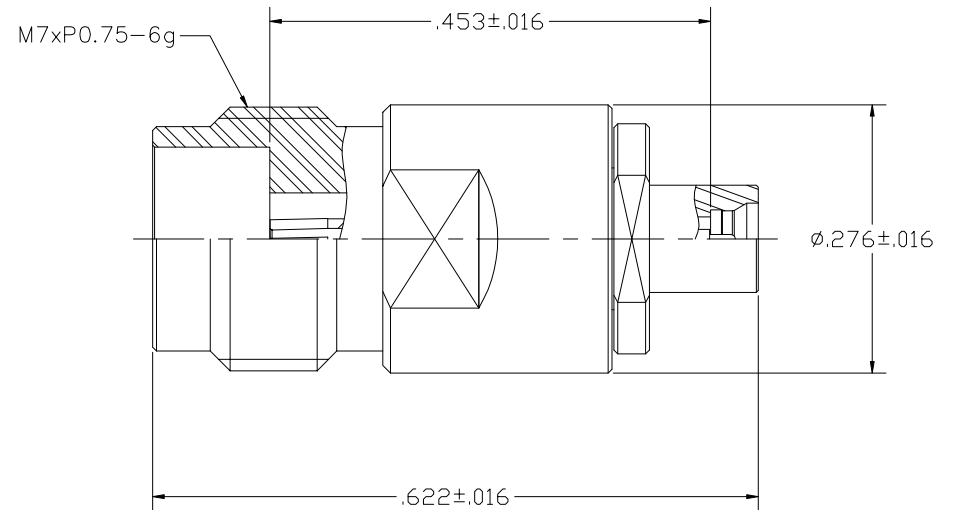

| | | | | | | |
|--|---|----------------------|---|----------------------|------------------|-------|
|  <p>cinch CONNECTIVITY SOLUTIONS a harsco group</p> <p><small>This PROPRIETARY Document is property of Cinch Connectivity Solutions. It is confidential in nature, non-transferable, and leased with the clear understanding that it is not traced or copied without permission and is returnable upon demand.</small></p> <p><small>INTERPRET DRAWING IN ACCORDANCE WITH ASME Y14.5-2009.</small></p> | Model No: | 134-1000-038 | <h1>JOHNSON</h1> | | | |
| | RoHS <input checked="" type="checkbox"/> | Cage Code | Title: ADAPTER ASSEMBLY, 2.4MM FEMALE TO SMP3 MALE | | | |
| | (EU)/2015/863 COMPLIANT | 3RD ANGLE PROJECTION | Drawing No. | REV. | | |
| | UNLESS OTHERWISE SPECIFIED UNITS: INCH | Drawn by: | 134-1000-038 | 1 | | |
| .XXX±.008 | TOMMY REN | Date: | Size | DO NOT SCALE DRAWING | Workmanship Std: | Sheet |
| .XXXX±.004 | 09/04/2020 | B | NONE | 1 OF 1 | | |
| ANGLES±5° | | | | | | |