

# Views from "X"

6-Pole  
(5+1)

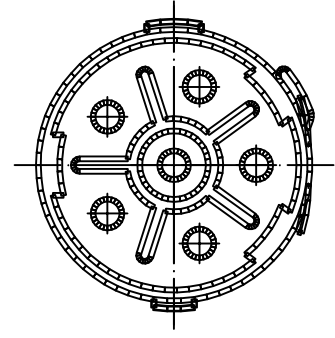

8-Pole

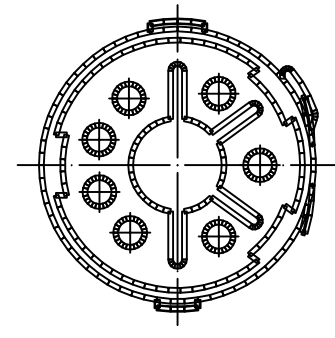

Cable Diameter  
7 - 12 mm

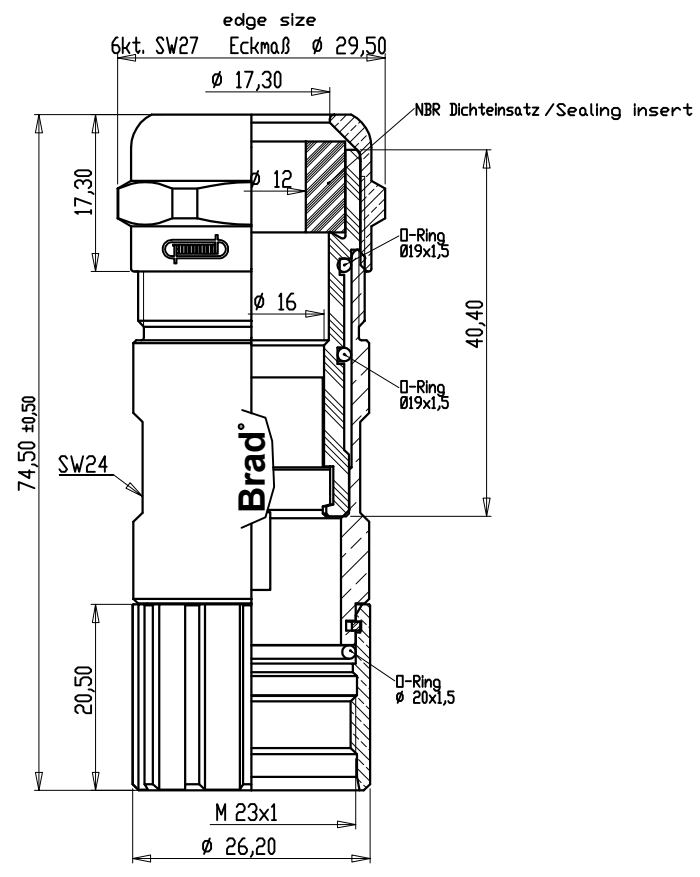

Cable Diameter  
11 - 17 mm

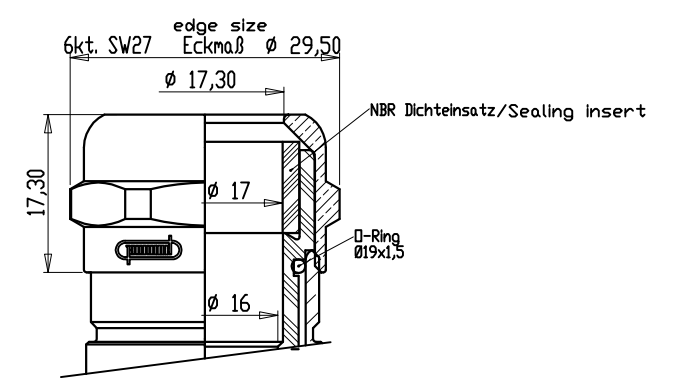

	Cable Diameter	Crimp Contacts	Without Contacts
6 Pole (5+PE)	7 - 12mm	KAP6S00-105	KAP6S00-005
		1202330001	1202330003
	11 - 17mm	KAP6S00-109	KAP6S00-009
		1202330002	1202330004
	Crimp range*	0,75-2,5mm <sup>2</sup>	
8 Pole	7 - 12mm	KAP8S00-115	KAP8S00-005
		1202330005	1202330007
	11 - 17mm	KAP8S00-119	KAP8S00-009
		1202330006	1202330008
	Crimp range*	0,25-1,0mm <sup>2</sup> /0,75-2,5mm <sup>2</sup>	

\*Crimp range only applies to "Crimp Contacts" version

Notes:

Tolerances (unless specified): DIN ISO 2768 m

DESCRIPTION EC NO.: WEU2009-0135 DRWN: BBRAUCH 2008/11/18 CH'KD: --- APPR: JKOLB 2009/03/02	QUALITY SYMBOLS	GENERAL TOLERANCES (UNLESS SPECIFIED)		DIMENSION STYLE	SCALE	DESIGN UNITS	FIRST ANGLE PROJECTION
	▽ = 0 ∇ = 0	mm	INCH	MM	---	METRIC	
		4 PLACES ±----	±----	DRAWN BY	DATE	M23 FIELD-ATTACHABLE CABLE CONNECTOR FEMALE STRAIGHT	
		3 PLACES ±----	±----	BB	2008/11/18		
		2 PLACES ±0.05	±----	CHECKED BY	DATE		
	1 PLACE ±0.1	±----	JKO	2008/12/09	MOLEX INCORPORATED		
	ANGULAR ± --- °		APPROVED BY	DATE			
	DRAFT WHERE APPLICABLE MUST REMAIN WITHIN DIMENSIONS		MATERIAL NO.	see table	DOCUMENT NO.	SD-120233-001	SHEET NO. 1 OF 1
1	REV	SIZE A3		THIS DRAWING CONTAINS INFORMATION THAT IS PROPRIETARY TO MOLEX INCORPORATED AND SHOULD NOT BE USED WITHOUT WRITTEN PERMISSION			