

REV	CHANGE	DATE	DRN	CHK
	Drawn	03/06/17	SJ	T

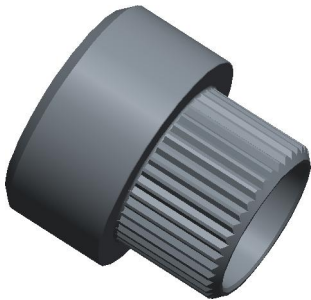

TOLERANCE DETAILS		
1	A	±0.004 [±0.01]
2	B	±0.002 [±0.05]
3	C	+0.004 [+0.10] -0.001 [-0.02]
4	F	±0.005 [±0.12]
5	G	±0.005 [±0.12]
6	H	±0.010 [±0.25]
7	J	±0.005 [±0.12]

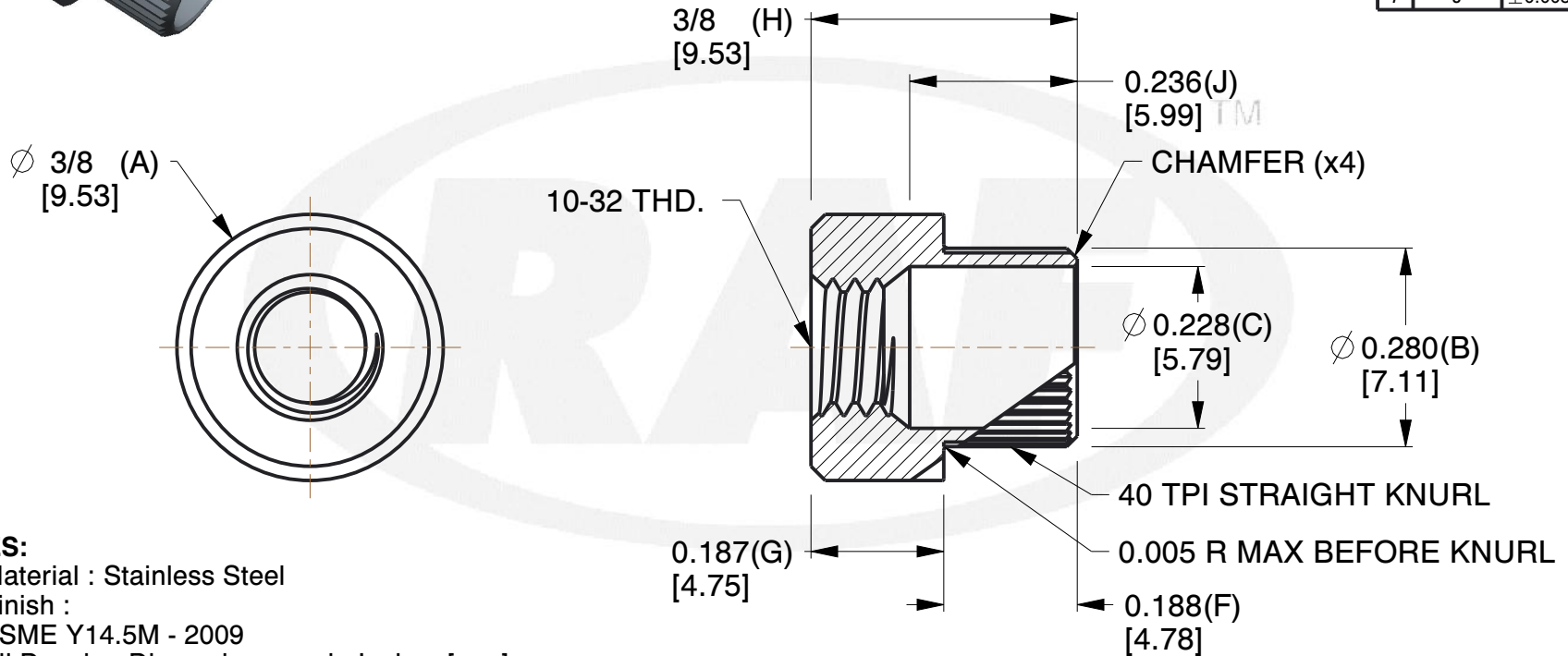

NOTES:

1. Material : Stainless Steel
2. Finish :
3. ASME Y14.5M - 2009
4. All Drawing Dimensions are in Inches [mm]
5. Unless otherwise specified; Edge Breaks, Radii or Countersinks 0.005-0.015
6. Threads are Supplied Cut or Rolled at RAF's Option Unless Noted on Order.
7. Threads are to Commercial 2A and 2B Standards per Handbook H-28 (Part 1)

COMPONENT	PANEL SCREW
1004-188-SS	SCALE
PANEL SCREW RETAINER	4.00
STYLE A	SHEET
	1 of 1



95 Silvermine Rd., Seymour CT 06483
Tel: 203-888-2133, Fax: 203-888-9860

This Drawing is the Property of RAF. It contains confidential, proprietary information that is RAF property. Do not disclose to or duplicate for others except as authorized by RAF.

TOLERANCES
ALL DIMENSIONS ARE INCHES (UNLESS OTHERWISE SPECIFIED)
METALLIC
LENGTHS < 6 INCHES ± 0.005
LENGTH > 6 INCHES ± 0.010
DIAMETERS: ± 0.005
NON-METALLIC
LENGTH: ± 0.010 DIAMETERS: ± 0.010
INTERNAL THREADS:
MINIMUM THREAD DEPTH