

**NOTES**

1. MATE WITHS : 51067 SERIES
2. MATERIAL  
 WAFER : PBTP (G.F.15%), UL94V-0  
 PIN : [PHOS.BRO., PRE-TINNED (t=0.254)]
3. COLOR OF WAFER  
 CORRESPONDS TO LAST DIGIT OF ENG. NO.  
 WHITE : 53265-\*\*10  
 BLACK : 53265-\*\*11  
 RED : 53265-\*\*12  
 YELLOW : 53265-\*\*13  
 BLUE : 53265-\*\*14

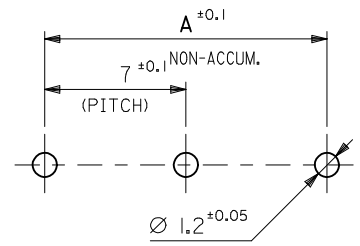

RECOMMENDED P.C. BOARD HOLE DIM. (REF.)  
(t=1.6)

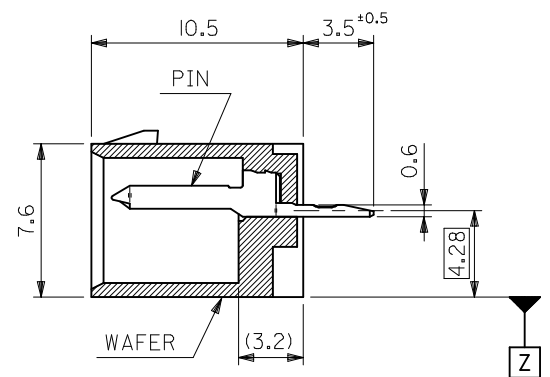

|     |      |      |      |                  |      |
|-----|------|------|------|------------------|------|
| 8.7 | 54.6 | 53.2 | 49.0 | 53265-081*       | 8    |
| ↑   | 47.6 | 46.2 | 42.0 | ↑ -071*          | 7    |
|     | 40.6 | 39.2 | 35.0 | ↑ -061*          | 6    |
|     | 33.6 | 32.2 | 28.0 | ↑ -051*          | 5    |
| ↓   | 26.6 | 25.2 | 21.0 | ↓ -041*          | 4    |
| 8.7 | 19.6 | 18.2 | 14.0 | ↓ -031*          | 3    |
| 6.1 | 12.6 | 11.2 | 7.0  | 53265-021*       | 2    |
| (D) | C    | B    | A    | TRAY PACKAGE     | CKT. |
|     |      |      |      | ORDER No. オーダー番号 |      |

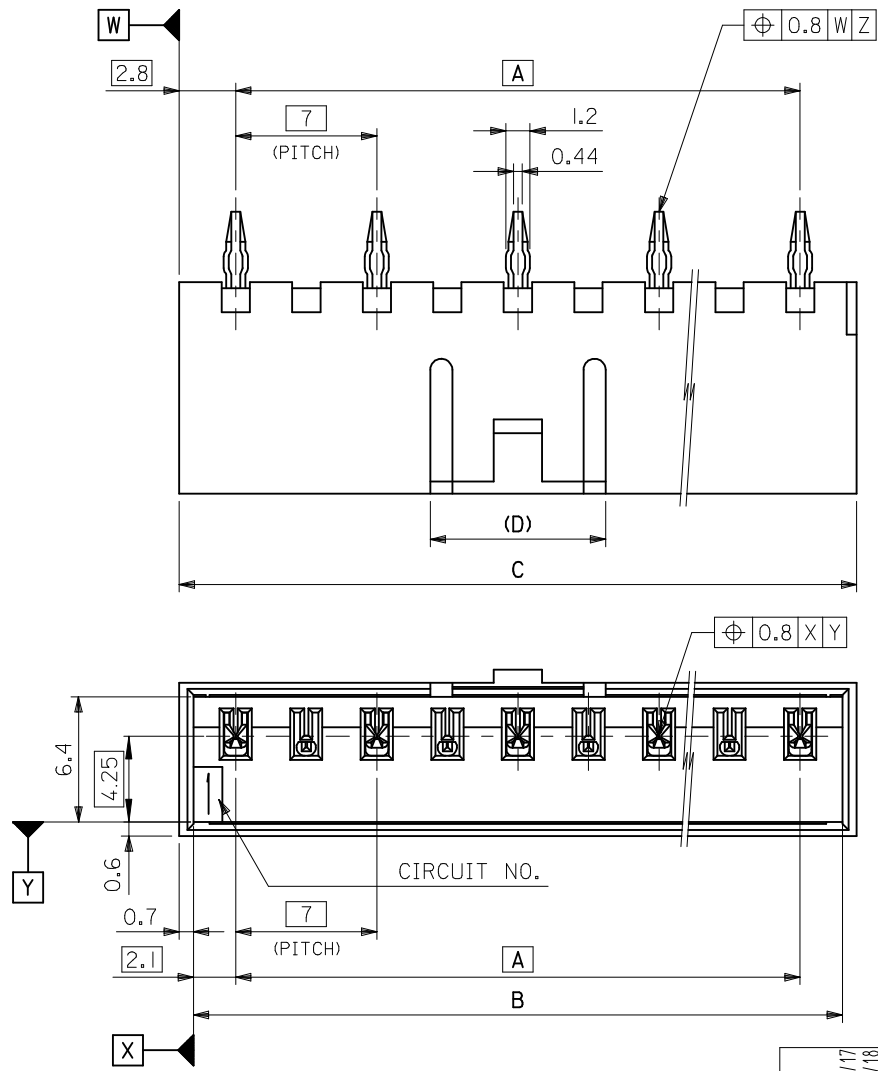

|                                                                                                             |                                       |             |                            |                                                                                                                               |                                           |              |                        |              |                          |  |
|-------------------------------------------------------------------------------------------------------------|---------------------------------------|-------------|----------------------------|-------------------------------------------------------------------------------------------------------------------------------|-------------------------------------------|--------------|------------------------|--------------|--------------------------|--|
| REVISED<br>EC NO: J2009-1054<br>DRWN:MMABEI 2009/02/17<br>CHKD:HYAJIMA 2009/02/18<br>APPR:NUKITA 2009/02/18 | GENERAL TOLERANCES (UNLESS SPECIFIED) |             | DIMENSION STYLE<br>MM ONLY |                                                                                                                               | SCALE<br>---                              |              | DESIGN UNITS<br>METRIC |              | MODEL NO.<br>53265-***1* |  |
|                                                                                                             | 10 UNDER                              | ±0.2        | DRAWN BY                   | DATE                                                                                                                          | TITLE                                     |              |                        |              |                          |  |
|                                                                                                             | 10 OVER 30 UNDER                      | ±0.25       | H.HIRAMOTO                 | '94/01/10                                                                                                                     | 7.0 WIRE TO BOARD CONN.<br>WAFER ASSY ST. |              |                        |              |                          |  |
|                                                                                                             | 30 OVER                               | ±0.30       | M.FUKUSHIMA                | '94/01/11                                                                                                                     |                                           |              |                        |              |                          |  |
| ANGULAR ±3 °                                                                                                |                                       | APPROVED BY |                            | DATE                                                                                                                          |                                           | MATERIAL NO. |                        | DOCUMENT NO. |                          |  |
| DRAFT WHERE APPLICABLE MUST REMAIN WITHIN DIMENSIONS                                                        |                                       | M.FUKUSHIMA |                            | '94/01/11                                                                                                                     |                                           | SEE TABLE    |                        | SD-53265-008 |                          |  |
|                                                                                                             |                                       | SIZE        |                            | THIS DRAWING CONTAINS INFORMATION THAT IS PROPRIETARY TO MOLEX INCORPORATED AND SHOULD NOT BE USED WITHOUT WRITTEN PERMISSION |                                           |              |                        |              |                          |  |
|                                                                                                             |                                       | A3          |                            |                                                                                                                               |                                           |              |                        |              |                          |  |