

TPS6108x High-Voltage DC-DC Boost Converter With 0.5-A, 1.3-A Integrated Switch

1 Features

- 2.5-V to 6-V Input Voltage Range
- Up to 27-V Output Voltage
- 0.5-A Integrated Switch (TPS61080)
1.3-A Integrated Switch (TPS61081)
- 12-V/400-mA and 24-V/170-mA From 5-V Input (Typical)
- Integrated Power Diode
- 1.2-MHz/600-kHz Selectable Fixed Switching Frequency
- Input-to-Output Isolation
- Short-Circuit Protection
- Programmable Soft Start
- Overvoltage Protection
- Up to 87% Efficiency
- 10-Pin 3-mm × 3-mm QFN Package

2 Applications

- 3.3-V to 12-V, 5-V to 12-V, and 24-V Boost Converter
- White LED Backlight for Media Form Factor Display
- OLED Power Supply
- xDSL Applications
- TFT-LCD Bias Supply
- White LED Flash Light

4 5-V To 12-V, 250-mA Step-Up DC-DC Converter

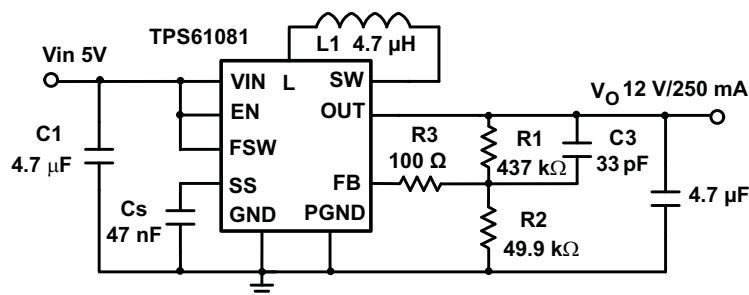

L1: TDK VLCF5020T-4R7N1R7-1
C1: Murata GRM188R60J105K
C2: Murata GRM219R61C475K

C3: Feed forward capacitor for stability
R3: Noise decoupling resistor
Cs: Soft start programming capacitor

3 Description

The TPS6108x is a 1.2 MHz/600 kHz fixed-frequency boost regulator designed for high integration, which integrates a power switch, an I/O isolation switch, and a power diode. When a short-circuit condition is detected, the isolation switch opens up to disconnect the output from the input. As a result, the IC protects itself and the input source from any pin, except VIN, from being shorted to ground. The isolation switch also disconnects the output from input during shutdown to prevent any leakage current. Other provisions for protection include 0.5 A/1.3 A peak-to-peak overcurrent protection, programmable soft start (SS), over voltage protection (OVP), thermal shutdown, and under voltage lockout (UVLO).

The IC operates from input supplies including single Li-ion battery, triple NiMH, and regulated 5 V, such as USB output. The output can be boosted up to 27 V. TPS6108x can provide the supply voltages of OLED, TFT-LCD bias, 12-V and 24-V power rails. The output of TPS6108x can also be configured as a current source to power up to seven WLEDs in flash light applications.

Device Information⁽¹⁾

PART NUMBER	PACKAGE	BODY SIZE (NOM)
TPS61080	VSON (10)	3.00 mm × 3.00 mm
TPS61081		

(1) For all available packages, see the orderable addendum at the end of the datasheet.



Table of Contents

1 Features	1	9.3 Feature Description	10
2 Applications	1	9.4 Device Functional Modes	11
3 Description	1	10 Application and Implementation	13
4 5-V To 12-V, 250-mA Step-Up DC-DC Converter	1	10.1 Application Information	13
5 Revision History	2	10.2 Typical Application	15
6 Device Comparison Table	3	10.3 System Examples	18
7 Pin Configuration and Functions	3	11 Power Supply Recommendations	20
8 Specifications	4	12 Layout	20
8.1 Absolute Maximum Ratings	4	12.1 Layout Guidelines	20
8.2 ESD Ratings	4	12.2 Layout Example	20
8.3 Recommended Operating Conditions	4	13 Device and Documentation Support	21
8.4 Thermal Information	4	13.1 Device Support	21
8.5 Electrical Characteristics	5	13.2 Related Links	21
8.6 Typical Characteristics	6	13.3 Trademarks	21
9 Detailed Description	9	13.4 Electrostatic Discharge Caution	21
9.1 Overview	9	13.5 Glossary	21
9.2 Functional Block Diagram	9	14 Mechanical, Packaging, and Orderable Information	21

5 Revision History

Changes from Revision D (April 2013) to Revision E

Page

- Added *Device Information* and *ESD Ratings* tables, *Feature Description* section, *Device Functional Modes*, *Application and Implementation* section, *Power Supply Recommendations* section, *Layout* section, *Device and Documentation Support* section, and *Mechanical, Packaging, and Orderable Information* section **1**

Changes from Revision C (July 2011) to Revision D

Page

- Changed Note 2 of the Electrical Characteristics table **5**
- Changed the first paragraph of the START UP section **10**

Changes from Revision B (January 2007) to Revision C

Page

- Added a Max value of 30 μ F to C_{OUT} in the Recommended Operating Conditions Table **4**
- Added sentence "The output capacitor value must be...." to the Input and Output Capacitor Selection section..... **16**

Changes from Revision A (February 2006) to Revision B

Page

- Changed from a 1 page Product Preview to the full data sheet..... **1**

Changes from Original (February 2006) to Revision A

Page

- Changed the Typical Application circuit..... **1**

6 Device Comparison Table

OVERCURRENT LIMIT	PART NUMBER ⁽¹⁾
0.5-A (min)	TPS61080
1.3-A (min)	TPS61081

(1) For complete orderable information see [Mechanical, Packaging, and Orderable Information](#) at the end of this data sheet.

7 Pin Configuration and Functions

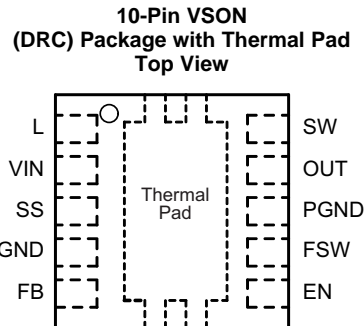

Pin Functions

PIN		I/O	DESCRIPTION
NAME	NO.		
EN	6	I	Enable pin. When the voltage of this pin falls below enable threshold for more than 74 ms, the IC turns off and consumes less than 2 μ A current.
FB	5	I	Voltage feedback pin for the output regulation. It is regulated to an internal reference voltage. An external voltage divider from the output to GND with the center tap connected to this pin programs the regulated voltage. This pin can also be connected to a low side current sense resistor to program current regulation.
FSW	7	I	Switching frequency selection pin. Logic high on the pin selects 1.2 MHz, while logic low reduces the frequency to 600 kHz for better light load efficiency.
GND	4		Signal ground of the IC
L	1	I	The inductor is connected between this pin and the SW pin. This pin connects to the source of the isolation FET as well. Minimize trace area at this pin to reduce EMI.
OUT	9	O	Output of the boost regulator. When the output voltage exceeds the 27-V overvoltage protection (OVP) threshold, the PWM switch turns off until Vout drops 0.7V below the overvoltage threshold.
PGND	8		Power ground of the IC. It is connected to the source of the PWM switch. This pin should be made very close to the output capacitor in layout.
SS	3	I	Soft start programming pin. A capacitor between the SS pin and GND pin programs soft start timing.
SW	10	I	Switching node of the IC. Connect the inductor between this pin and the L pin.
VIN	2	I	Input pin to the IC. It is the input to the boost regulator, and also powers the IC circuit. It is connected to the drain of the isolation FET as well.
Thermal Pad	–		The thermal pad should be soldered to the analog ground. If possible, use thermal via to connect to ground plane for ideal power dissipation.

8 Specifications

8.1 Absolute Maximum Ratings

over operating free-air temperature range (unless otherwise noted)⁽¹⁾

	MIN	MAX	UNIT
Supply Voltages on pin VIN ⁽²⁾	-0.3	7	V
Voltages on pins EN, FB, SS, L and FSW ⁽²⁾	-0.3	7	V
Voltage on pin OUT ⁽²⁾		30V	V
Voltage on pin SW ⁽²⁾		30V	V
Continuous Power Dissipation	See Thermal Information		
Operating Junction Temperature Range	-40	150	°C
Storage temperature range	-65	150	°C

- (1) Stresses beyond those listed under *Absolute Maximum Ratings* may cause permanent damage to the device. These are stress ratings only, and functional operation of the device at these or any other conditions beyond those indicated under *Recommended Operating Conditions* is not implied. Exposure to absolute-maximum-rated conditions for extended periods may affect device reliability.
- (2) All voltage values are with respect to network ground terminal.

8.2 ESD Ratings

		VALUE	UNIT
V _(ESD) Electrostatic discharge	Human-body model (HBM), per ANSI/ESDA/JEDEC JS-001 ⁽¹⁾	±2000	V
	Charged-device model (CDM), per JEDEC specification JESD22-C101 ⁽²⁾	±750	

- (1) JEDEC document JEP155 states that 500-V HBM allows safe manufacturing with a standard ESD control process.
- (2) JEDEC document JEP157 states that 250-V CDM allows safe manufacturing with a standard ESD control process.

8.3 Recommended Operating Conditions

over operating free-air temperature range (unless otherwise noted)

		MIN	NOM	MAX	UNIT
V _{IN}	Input voltage range	2.5		6.0	V
V _{OUT}	Output voltage range	V _{IN}		27	V
L	Inductor ⁽¹⁾	4.7		10	μH
C _{IN}	Input capacitor ⁽¹⁾	1			μF
C _{OUT}	Output capacitor ⁽¹⁾	4.7		30	μF
T _A	Operating ambient temperature	-40		85	°C
T _J	Operating junction temperature	-40		125	°C

- (1) Refer to [Application and Implementation](#) for further information

8.4 Thermal Information

THERMAL METRIC ⁽¹⁾		TPS6108x	UNIT
		DRC	
		10 PINS	
R _{θJA}	Junction-to-ambient thermal resistance	45.3	°C/W
R _{θJC(top)}	Junction-to-case (top) thermal resistance	52.2	
R _{θJB}	Junction-to-board thermal resistance	20.9	
ψ _{JT}	Junction-to-top characterization parameter	0.9	
ψ _{JB}	Junction-to-board characterization parameter	20.7	
R _{θJC(bot)}	Junction-to-case (bottom) thermal resistance	5.3	

- (1) For more information about traditional and new thermal metrics, see the *IC Package Thermal Metrics* application report, [SPRA953](#).

8.5 Electrical Characteristics

V_{IN} = 3.6 V, EN = V_{IN}, T_A = –40°C to 85°C, typical values are at T_A = 25°C (unless otherwise noted)

PARAMETER		TEST CONDITIONS	MIN	TYP	MAX	UNIT
SUPPLY CURRENT						
V _{IN}	Input voltage range		2.5		6.0	V
I _Q	Operating quiescent current into V _{IN}	Device switching no load			6	mA
I _{SD}	Shutdown current	EN = GND			1	μA
V _{UVLO}	Undervoltage lockout threshold	V _{IN} falling		1.65	1.8	V
V _{hys}	Undervoltage lockout hysteresis			50		mV
ENABLE						
V _{EN}	Enable level voltage	V _{IN} = 2.5 V to 6 V	1.2			V
	Disable level voltage	V _{IN} = 2.5 V to 6 V	0.4			
R _{en}	Enable pulldown resistor		400	800	1600	kΩ
t _{off}	EN pulse width to disable	EN high to low	74			ms
SOFT START						
I _{SS}	Soft start bias current	T _A = 25°C	4.75	5	5.25	μA
			4.6	5	5.4	
V _{clp}	SS pin to FB pin accuracy	V _{SS} = 500 mV	487	500	513	mV
FEEDBACK FB						
I _{FB}	Feedback input bias current	V _{FB} = 1.229 V	–100		100	nA
V _{FB}	Feedback regulation voltage		1.204	1.229	1.254	V
POWER SWITCH AND DIODE						
R _{DS(ON)}	Isolation MOSFET on-resistance			0.06	0.1	Ω
	N-channel MOSFET on-resistance	V _{IN} = V _{GS} = 3.6 V		0.17	0.22	Ω
		V _{IN} = V _{GS} = 2.5 V		0.2	0.32	
I _{LN_NFET}	N-channel leakage current	V _{DS} = 28 V		1	2	μA
V _F	Power diode forward voltage	I _d = 1 A		0.85	1	V
I _{LN_ISO}	Isolation FET leakage current	L pin to ground			1	μA
OC AND SC						
I _{LIM}	N-Channel MOSFET current limit ⁽¹⁾	TPS61080, FSW = High or FSW = Low	0.5	0.7	1.0	A
		TPS61081, FSW = High or FSW = Low	1.3	1.6	2.0	
I _{SC}	Short circuit current limit	TPS61080	1.0			A
		TPS61081	2.0			
t _{scd}	Short circuit delay time		13			μs
t _{scr}	Short circuit release time		57			ms
V _{SC}	OUT short detection threshold ⁽²⁾	V _{IN} – V _{OUT}	1.4			V
OSCILLATOR						
f _S	Oscillator frequency	FSW pin high	1.0	1.2	1.5	MHz
		FSW pin low	0.5	0.6	0.7	
D _{max}	Maximum duty cycle	FB = 1.0 V	90%	94%		
D _{min}	Minimum duty cycle		5%			
R _{fsw}	FSW pin pulldown resistance		400	800	1600	kΩ
V _{FSW}	FSW high logic		1.6			V
	FSW low logic		0.8			

(1) V_{IN} = 3.6 V, V_{OUT} = 15 V, Duty cycle = 76%. See Figure 5 to Figure 8 for other operation conditions.

(2) OUT short circuit condition is detected if OUT stays lower than V_{IN} – V_{SC} for 1.7 ms after IC enables. See the [Start Up](#) section for details.

Electrical Characteristics (continued)

VIN = 3.6 V, EN = VIN, TA = -40°C to 85°C, typical values are at TA = 25°C (unless otherwise noted)

PARAMETER		TEST CONDITIONS	MIN	TYP	MAX	UNIT
OVP						
Vovp	Output overvoltage protection	VOUT rising	27	28	29	V
	Output overvoltage protection hysteresis	VOUT falling		0.7		V
THERMAL SHUTDOWN						
Tshutdown	Thermal shutdown threshold			160		°C
Thysteresis	Thermal shutdown threshold hysteresis			15		°C

8.6 Typical Characteristics

Table 1. Table Of Graphs

		FIGURE
Efficiency	Vs IOUT, VIN = 3.6 V OUT = 12 V, 15 V, 20 V, 25 V, FSW = HIGH, L = 4.7 μH	Figure 1
	Vs IOUT, VIN = 3.6 V OUT = 12 V, 15 V, 20 V, 25 V, FSW = LOW, L = 10 μH	Figure 2
	Vs IOUT, VIN = 3 V, 3.6 V, 5 V, OUT = 12 V, FSW = HIGH, L = 4.7 μH	Figure 3
	Vs IOUT, VIN = 3 V, 3.6 V, 5 V, OUT = 12 V, FSW = LOW, L = 10 μH	Figure 4
Overcurrent Limit	VIN = 3.0 V, 3.6 V, 5 V, FSW = High/Low	Figure 5 , Figure 6 , Figure 7 , Figure 8
Line Regulation	TPS61081, VIN = 2.5 V to 6 V, OUT = 12 V, IOUT = 100 mA	Figure 9
Load Regulation	TPS61081, VIN = 3.6 V, OUT = 12 V	Figure 10

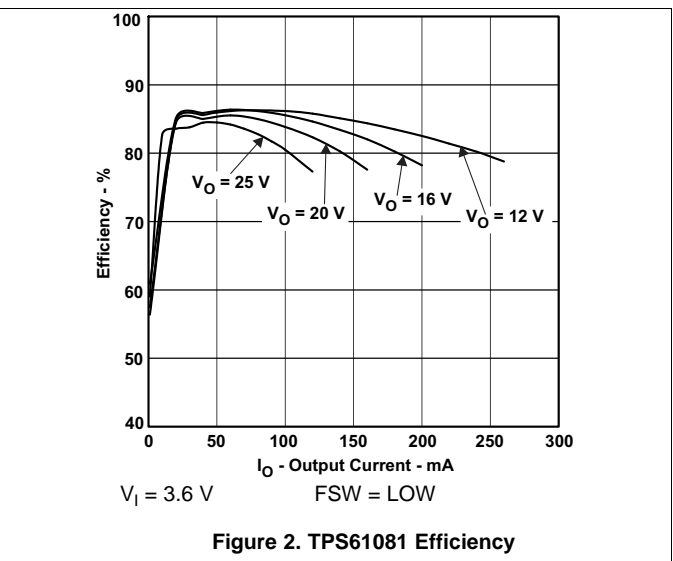
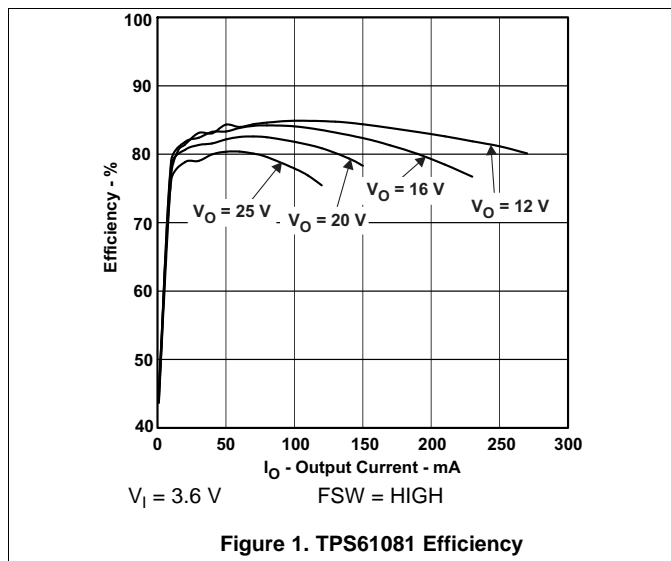

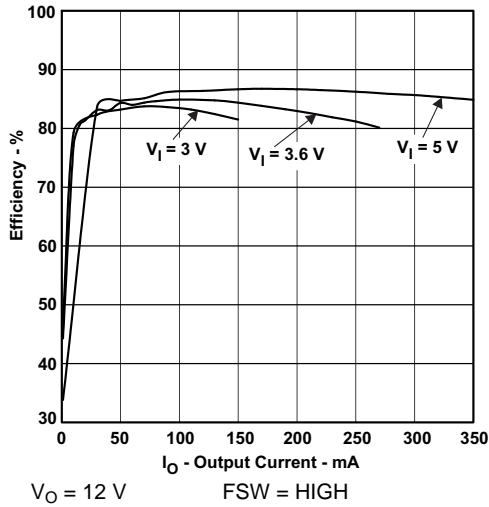

Figure 3. TPS61081 Efficiency

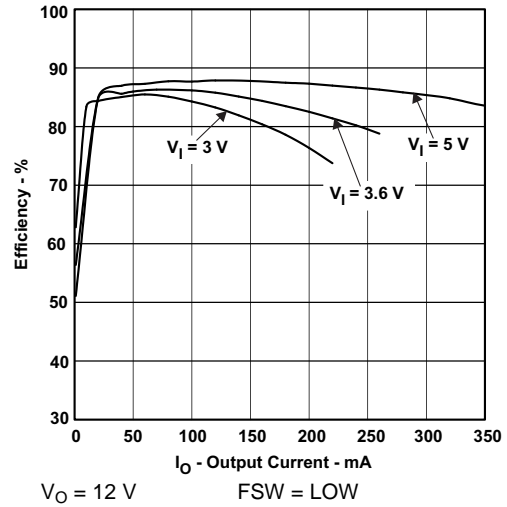

Figure 4. TPS61081 Efficiency

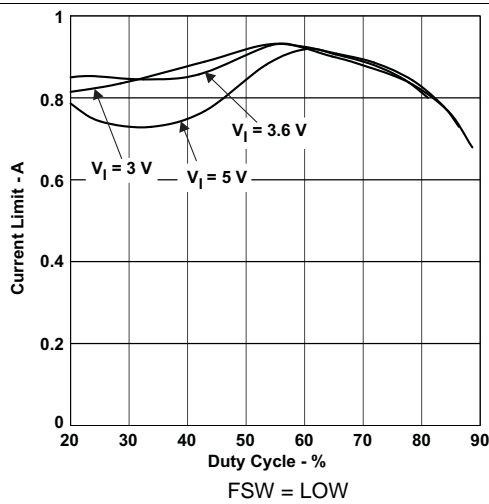

Figure 5. TPS61080 Overcurrent Limit

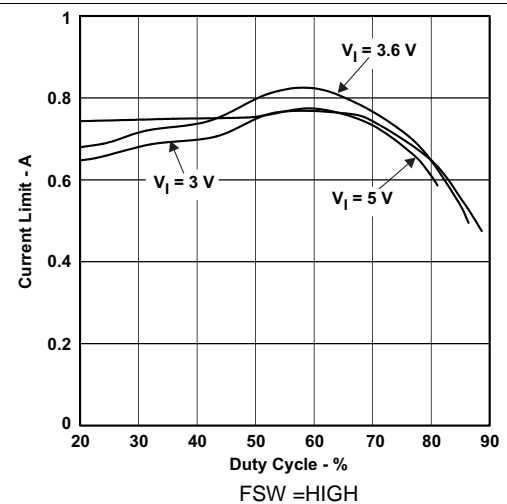

Figure 6. TPS61080 Overcurrent Limit

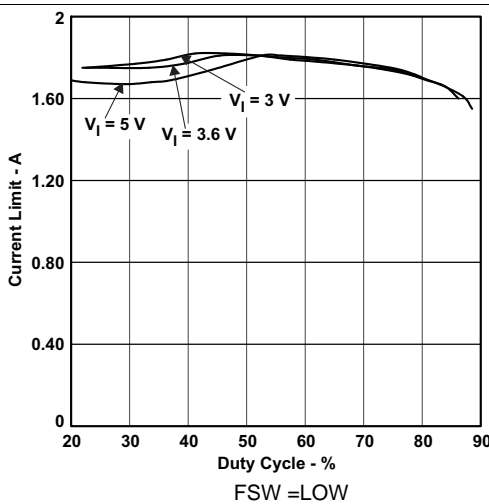

Figure 7. TPS61081 Overcurrent Limit

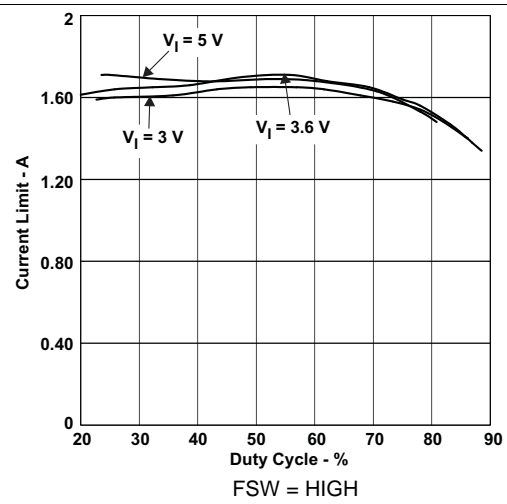

Figure 8. TPS61081 Overcurrent Limit

TPS61080, TPS61081

SLVS644E – FEBRUARY 2006 – REVISED DECEMBER 2014

www.ti.com

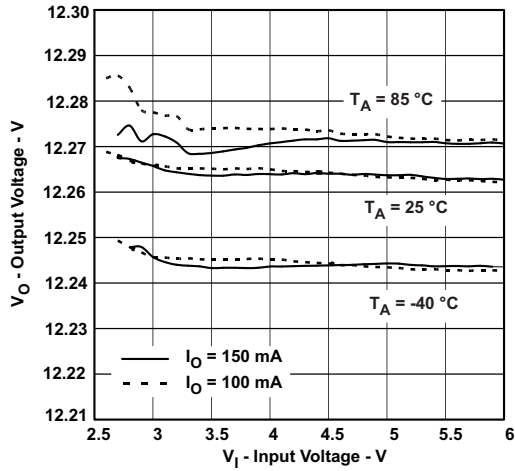

Figure 9. TPS61081 Line Regulation

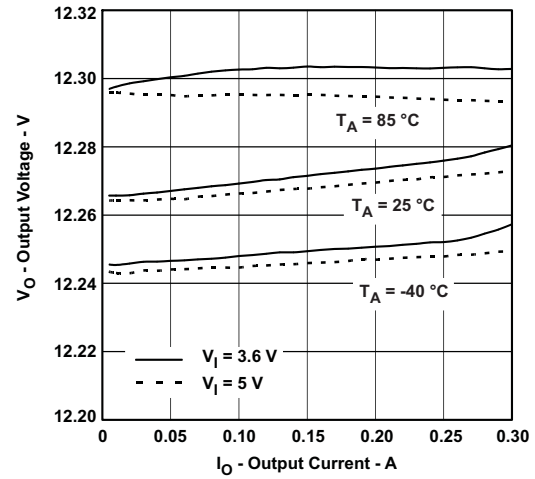

Figure 10. TPS61081 Load Regulation

9 Detailed Description

9.1 Overview

TPS6108x is a highly integrated boost regulator for up to 27-V output. In addition to the on-chip 0.5-A/1.2-A PWM switch and power diode, this IC also builds in an input side isolation switch as shown in the block diagram. One common issue with conventional boost regulator is the conduction path from input to output even when PWM switch is turned off. It creates three problems, inrush current during start up, output leakage voltage under shutdown, and unlimited short circuit current. To address these issues, TPS6108x turns off the isolation switch under shutdown mode and short circuit condition to eliminate any possible current path.

TPS6108x adopts current mode control with constant PWM (pulse width modulation) frequency. The switching frequency can be configured to either 600 kHz or 1.2 MHz through the FSW pin. 600 kHz improves light load efficiency, while 1.2 MHz allows using smaller external component. The PWM operation turns on the PWM switch at the beginning of each switching cycle. The input voltage is applied across the inductor and stores the energy as inductor current ramps up. The load current is provided by the output capacitor. When the inductor current across the threshold set by error amplifier output, the PWM switch is turned off, and the power diode is forward biased. The inductor transfers its stored energy to replenish the output capacitor. This operation repeats in the next switching cycle.

The error amplifier compares the FB pin voltage with an internal reference, and its output determines the duty cycle of the PWM switching. This close loop system requires loop compensation for stable operation. TPS6108x has internal compensation circuitry which accommodates a wide range of input and output voltages. The TPS6108x integrates slope compensation to the current ramp to avoid the sub-harmonic oscillation that is intrinsic to current mode control schemes.

9.2 Functional Block Diagram

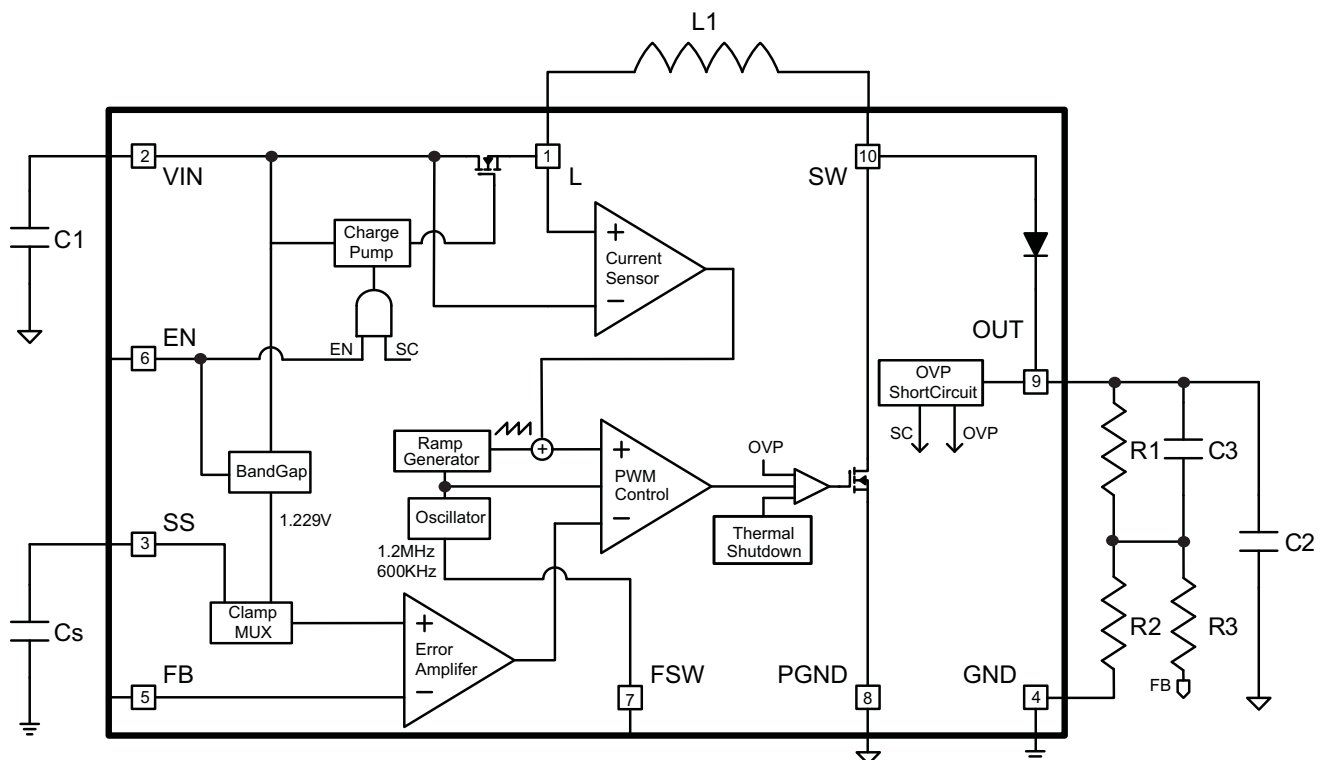

9.3 Feature Description

9.3.1 Start Up

TPS6108x turns on the isolation FET when the EN pin is pulled high, provided that the input voltage is higher than the undervoltage lockout threshold. The Vgs of the isolation FET is clamped to maintain high on-resistance and limits the current to 30mA charging the output capacitor. This feature limits the in-rush current and maximum start up current to 30mA. Once the output capacitor is charged to VIN, the IC removes the Vgs clamp to fully turn on the isolation FET and at the same time activates soft start by charging the capacitor on the SS pin. If OUT stays lower than VIN-Vsc following a 1.7ms delay after enable is taken high, the IC recognizes a short circuit condition. In this case, the isolation FET turns off, and IC remains off until the EN pin toggles or VIN cycles through power on reset (POR).

During the soft start phase, the SS pin capacitor is charged by internal bias current of the SS pin. The SS pin capacitor programs the ramp up slope. The SS pin voltage clamps the reference voltage of the FB pin, therefore the output capacitor rise time follows the SS pin voltage. Without the soft start, the inductor current could reach the overcurrent limit threshold, and there is potential for output overshoot. see the [Application and Implementation](#) section on selecting soft start capacitor values. Pulling the SS pin to ground disables the PWM switching. However, unlike being disabled by pulling EN low, the IC continues to draw quiescent current and the isolation FET remains on.

9.3.2 Overcurrent and Short Circuit Protection

TPS6108x has a pulse by pulse overcurrent limit feature which turns off the power switch once the inductor current reaches the overcurrent limit. The PWM circuitry resets itself at the beginning of the next switch cycle. The overcurrent threshold determines the available output current. However, the maximum output is also a function of the input voltage, output voltage, switching frequency and inductor value. Larger inductor values and 1.2MHz switching frequency increase the current output capability because of the reduced current ripple. See the APPLICATION INFORMATION section for the maximum output current calculation.

In typical boost converter topologies, if the output is grounded, turning off the power switch does not limit the current because a current path exists from the input to output through the inductor and power diode. To eliminate this path, TPS6108x turns off the isolation FET between the input and the inductor. This circuit is triggered when the inductor current remains above short circuit current limit for more than 13μs, or the OUT pin voltage falls below VIN-1.4V for more than 1.7ms. An internal catch-diode between the L pin and ground turns on to provide a current discharge path for the inductor. If the short is caused by the output being low, then the IC shuts down and waits for EN to be toggled or a POR. If the short protection is triggered by short circuit current limit, the IC attempts to start up one time. After 57ms, the IC restarts in a fashion described in the above section. If the short is cleared, the boost regulator properly starts up and reaches output regulation. However, after reaching regulation, if another event of short circuit current limit occurs, the IC goes into shutdown mode again, and the fault can only be cleared by toggling the EN pin or POR. Under a permanent short circuit, the IC shuts down after a start up failure and waits for POR or the EN pin toggling.

The same circuit also protects the ICs and external components when the SW pin is shorted to ground. These features provide much more comprehensive and reliable protection than the conventional boost regulator. [Table 2](#) lists the IC protection against the short of each IC pin.

Feature Description (continued)

Table 2. TPS6108x Short Circuit Protection Mode

SHORTED TO GND	FAULT DETECTION	IC OPERATION	HOW TO CLEAR THE FAULT
L, SW	INDUCTOR > I _{SC} for 13 μs	Turn off isolation FET	IC restarts after 57ms; If it happens again, the fault can only be cleared by toggling EN or POR.
OUT (during start up)	OUT <V _{in} – 1.4V for 2 ms	IC shuts down	Cleared by toggling EN or POR
OUT (after start up)	OUT <V _{in} – 1.4V without delay	IC shuts down	Cleared by toggling EN or POR
EN	N/A	IC disabled	N/A
FSW	N/A	600 kHz switching frequency	N/A
SS	N/A	Disable PWM switching and no output; but still dissipate quiescent current.	N/A
FB	N/A	Over voltage protection of the OUT pin	OUT voltage fails by OVP hysteresis
GND, PGND, VIN	N/A	N/A	N/A

9.3.3 Overvoltage Protection

When TPS6108x is configured as regulated current output as shown in the [Typical Application](#) section, the output voltage can run away if the current load is disconnected. The over voltage condition can also occur if the FB pin is shorted to the ground. To prevent the SW node and the output capacitor from exceeding the maximum voltage rating, an over voltage protection circuit turns off the boost regulator as soon as the output voltage exceeds the OVP threshold. When the output voltage falls 0.7 V below the OVP threshold, the regulator resumes the PWM switching unless the output voltage exceeds the OVP threshold.

9.3.4 Undervoltage Lockout (UVLO)

An undervoltage lockout prevents mis-operation of the device for input voltages below 1.65 V (typical). When the input voltage is below the undervoltage threshold, the device remains off and both PWM and isolation switch are turned off, providing isolation between input and output. The undervoltage lockout threshold is set below minimum operating voltage of 2.5 V to avoid any transient VIN dip to trigger UVLO and causes converter reset. For the VIN voltage between UVLO threshold and 2.5 V, the IC still maintains its operation. However, the spec is not assured.

9.3.5 Thermal Shutdown

An internal thermal shutdown turns off the isolation and PWM switches when the typical junction temperature of 160°C is exceeded. The IC restarts if the junction temperature drops by 15°C.

9.4 Device Functional Modes

9.4.1 Enable

Connecting the EN pin low turns off the power switch immediately, but keeps the isolation FET on. If the EN pin is logic low for more than 74 ms, the IC turns off the isolation FET and enters shutdown mode drawing less than 1 μA current. The enable input pin has an internal 800 kΩ pulldown resistor to disable the device when the pin is floating.

9.4.2 Frequency Selection

The FSW pin can be connected to either a logic high or logic low to program the switching frequency to 1.2 MHz or 600 kHz respectively. The 600 kHz switching frequency provides better efficiency because of lower switching losses. This advantage becomes more evident at light load when switching losses dominate overall losses. The higher switching frequency shrinks external component size and thus the size of power solution. High switching frequency also improves load transient response because the smaller value inductor takes less time to ramp up and down current. The other benefits of high switching frequency are lower output ripples and a higher maximum output current. Overall, it is recommended to use 1.2 MHz switching frequency unless light load efficiency is a major concern.

Device Functional Modes (continued)

The FSW pin has internal 800 kΩ pullup resistor to the VIN pin. Floating this pin programs the switching frequency to 1.2MHz.

9.4.3 Maximum and Minimum Output Current

The overcurrent limit in a boost converter limits the maximum input current and thus maximum input power from a given input voltage. Maximum output power is less than maximum input power due to power conversion losses. Therefore, the overcurrent limit, the input voltage, the output voltage and the conversion efficiency all affect maximum current output. Because the overcurrent limit clamps the peak inductor current, the current ripple must be subtracted to derive maximum DC current. The current ripple is a function of the switching frequency, the inductor value and the duty cycle.

$$I_p = \frac{1}{L \times \left(\frac{1}{V_{out} + V_f - V_{in}} + \frac{1}{V_{in}} \right) \times F_s} \quad (1)$$

where

I_p = inductor peak to peak ripple

L = inductor value

V_f = power diode forward voltage

F_s = Switching frequency

The following equations take into account of all the above factors for maximum output current calculation.

$$I_{out_max} = \frac{V_{in} \times \left(I_{lim} - \frac{I_p}{2} \right) \times \eta}{V_{out}} \quad (2)$$

where

I_{lim} = overcurrent limit

η = conversion efficiency

To minimize the variation in the overcurrent limit threshold, the TPS6108x uses the VIN and OUT pin voltage to compensate for the variation caused by the slope compensation. However, the threshold still has some dependency on the VIN and OUT voltage. Use [Figure 5](#) to [Figure 8](#) to identify the typical overcurrent limit in your application, and use 25% tolerance to account for temperature dependency and process variations.

Because of the minimum duty cycle of each power switching cycle of TPS6108x, the device can lose regulation at the very light load. Use the following equations to calculate PWM duty cycle under discontinues conduction mode (DCM).

$$I_{peak} = \sqrt{2 \times I_{load} \times \frac{V_{out} + V_f - V_{in}}{L \times F_s}}$$

$$D = L \times \frac{I_{peak}}{V_{in}} \times F_s \quad (3)$$

Where

I_{peak} = inductor peak to peak ripple in DCM

I_{load} = load current

D = PWM switching duty cycle

If the calculated duty cycle is less than 5%, minimum load should be considered to the boost output to ensure regulation. [Figure 20](#) provides quick reference to identify the minimum load requirements for two input voltages.

10 Application and Implementation

NOTE

Information in the following applications sections is not part of the TI component specification, and TI does not warrant its accuracy or completeness. TI's customers are responsible for determining suitability of components for their purposes. Customers should validate and test their design implementation to confirm system functionality.

10.1 Application Information

TPS6108x is a highly integrated boost regulator for up to 27-V output with integration of a PWM switch, a power diode as well as an input side isolation switch. TPS6108x adopts current mode control with constant PWM (pulse width modulation) frequency. The switching frequency can be configured to either 600 kHz or 1.2 MHz through the FSW pin.

10.1.1 Program Output Voltage

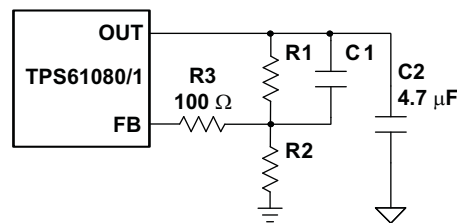

Figure 11. Feed Forward Capacitor Connecting With Feedback Resistor Divider

To program the output voltage, select the values of R1 and R2 (See Figure 11) according to the following equation.

$$R1 = R2 \times \left(\frac{V_{out}}{1.229V} - 1 \right) \quad (4)$$

An optimum value for R2 is around 50kΩ which sets the current in the resistor divider chain to $1.229 V/50 k\Omega = 24.58 \mu A$. The output voltage tolerance depends on the V_{FB} accuracy and the resistor divider.

10.1.2 Feed Forward Capacitor

A feed forward capacitor on the feedback divider, shown in Figure 11, improves transient response and phase margin. This network creates a low frequency zero and high frequency pole at

$$F_z = \frac{1}{2\pi R1 \times C1} \quad (5)$$

$$F_p = \left(\frac{1}{R1} + \frac{1}{R2} \right) \frac{1}{2\pi C1} \quad (6)$$

The frequency of the pole is determined by C1 and paralleled resistance of R1 and R2. For high output voltage, R1 is much bigger than R2. So

$$F_p = \frac{1}{2\pi R2 C1} \text{ when } R1 \gg R2. \quad (7)$$

The loop gains more phase margin from this network when $(F_z + F_p)/2$ is placed right at crossover frequency, which is approximately 15 kHz with recommended L and C. The typical value for the zero frequency is between 1 kHz to 10 kHz. For high output voltage, the zero and pole are further apart which makes the feed forward capacitor very effective. For low output voltage, the benefit of the feed forward capacitor is less visible. Table 3 gives the typical R1, R2 and the feed forward capacitor values at the certain output voltage. However, the transient response is not greatly improved which implies that the zero frequency is too high or low to increase the phase margin.

Table 3. Recommended Feed Forward Capacitor Values With Different Output Voltage

Output Voltage	R1	R2	C1(Feed Forward)
12V	437kΩ	49.9kΩ	33pF
16V	600kΩ	49.9kΩ	42pF
20V	762kΩ	49.9kΩ	56pF
25V	582kΩ	30.1kΩ	120pF

The 100-Ω resistor is added to reduce noise coupling from the OUT to the FB pin through the feed forward capacitor. Without the resistor, the regulator may oscillate at high output current.

10.1.3 Soft Start Capacitor

The voltage at the SS pin clamps the internal reference voltage, which allows the output voltage to ramp up slowly. The soft start time is calculated as

$$t_{SS} = \frac{C_{SS} \times 1.229}{I_{SS}} \quad (8)$$

where

C_{SS} = soft start capacitor

I_{SS} = soft start bias current (TYP 5 μA)

1.229 V is the typical value of the reference voltage.

During start up, input current has to be supplied to charge the output capacitor. This current is proportional to rising slope of the output voltage, and peaks when output reaches regulation.

$$I_{in_cout} = C_{out} \frac{I_{SS} \times V_{out}}{C_{SS} \times V_{in} \times \eta} \quad (9)$$

Where

I_{in_cout} = additional input current for charging the output capacitor

The maximum input during soft start is

$$I_{in_ss} = I_{in_cout} + \frac{V_{out}}{V_{in} \times \eta} \times I_{load} \quad (10)$$

Output overshoot can occur if the input current at startup exceeds the inductor saturation current and/or reaches current limit because the error amplifier loses control of the voltage feedback loop. The in-rush current can also pulldown input sources, potentially causing system reset. Therefore, select C_{SS} to make I_{in_ss} stay below the inductor saturation current, the IC overcurrent limit and the input's maximum supply current.

TPS6108x can also be configured for constant current output, as shown in the typical applications. In this configuration, a current sense resistor is connected to FB pin for output current regulation. In order to reduce power loss on the sense resistor, FB pin reference voltage can be lowered by connecting a resistor to the SS pin. The new reference voltage is simply the resistor value times the SS pin bias current. However, keep in mind that this reference has higher tolerance due to the tolerance of the bias current and sense resistor, and the offset of the clamp circuit. Refer to the specification V_{CLP} and I_{SS} to calculate the tolerance as following.

$$K_{ref} = \sqrt{K_{V_{clp}}^2 + K_{I_{SS}}^2 + K_R^2} \quad (11)$$

Where

K_{ref} = percentage tolerance of the FB reference voltage.

$K_{V_{clp}}$ = percentage tolerance of the clamp circuit.

$K_{I_{SS}}$ = percentage tolerance of the SS pin bias current.

K_R = percentage tolerance of the SS pin resistor.

Without considering the SS pin resistor tolerance, the FB reference voltage has ±5.6% under the room temperature.

10.2 Typical Application

Figure 12 shows typical application circuit for a step-up DC-DC converter.

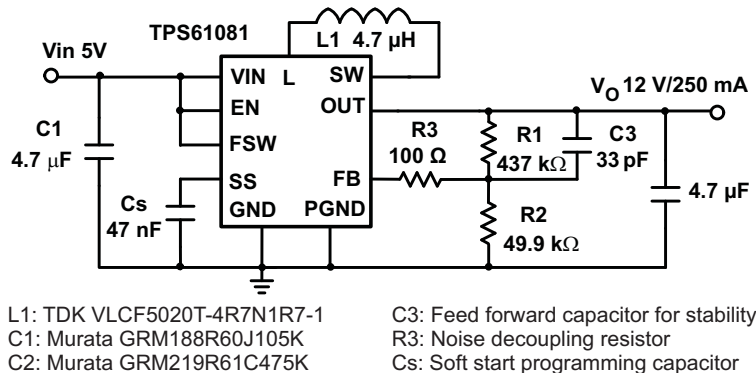

See [Third-Party Products Disclaimer](#).

Figure 12. 3.3 V to 12 V, 80 mA Step-Up DC-DC Converter

10.2.1 Design Requirements

Table 4. TPS6108x 12-V Output Design Parameters

DESIGN PARAMETERS	VALUES
Input Voltage Range	2.5 V to 6 V
Output Voltage	12 V
Transient Response	+/- 250 mV
Input Voltage Ripple	+/- 50 mV
Output Current	250 mA
Operating Frequency	1.2 MHz

10.2.2 Detailed Design Procedure

10.2.2.1 Inductor Selection

Because the selection of the inductor affects steady state operation, transient behavior and loop stability, the inductor is the most important component in power regulator design. There are three important inductor specifications, inductor value, DC resistance and saturation current. Considering inductor value alone is not enough.

The inductance value of the inductor determines the inductor ripple current. It is generally recommended to set peak to peak ripple current given by Equation 4 to 30–40% of DC current. Also, the inductor value should not be beyond the range in the recommended operating conditions table. It is a good compromise of power losses and inductor size. Inductor DC current can be calculated as

$$I_{L_DC} = \frac{V_{out} \times I_{out}}{V_{in} \times \eta} \quad (12)$$

The internal loop compensation for PWM control is optimized for the external component shown in the typical application circuit with consideration of component tolerance. Inductor values can have $\pm 20\%$ tolerance with no current bias. When the inductor current approaches saturation level, its inductance can decrease 20% to 35% from the 0A value depending on how the inductor vendor defines saturation current. Using an inductor with a smaller inductance value forces discontinuous PWM in which inductor current ramps down to zero before the end of each switching cycle. It reduces the boost converter's maximum output current, causes large input voltage ripple and reduces efficiency. An inductor with larger inductance reduces the gain and phase margin of the feedback loop, possibly resulting in instability.

For these reasons, 10 μ H inductors are recommended for TPS61080 and 4.7 μ H inductors for TPS61081 for most applications. However, 10 μ H inductor is also suitable for 600 kHz switching frequency.

Regulator efficiency is dependent on the resistance of its high current path and switching losses associated with the PWM switch and power diode. Although the TPS6108x has optimized the internal switches, the overall efficiency still relies on inductor's DC resistance (DCR); Lower DCR improves efficiency. However, there is a trade off between DCR and inductor size, and shielded inductors typically have higher DCR than unshielded ones. [Table 5](#) list recommended inductor models.

Table 5. Recommended Inductor For TPS6108x

TPS61080	L (μ H)	DCR MAX (m Ω)	SATURATION CURRENT (A)	Size (LxWxH mm)	VENDOR
VLCF4018T	10	188	0.74	4.0 x 4.0 x 1.8	TDK
CDRH4D16NP	10	118	0.96	4.0 x 4.0 x 1.8	Sumida
LQH43CN100K	10	240	0.65	4.5 x 3.6 x 2.6	Murata
TPS61081	L (μ H)	DCR MAX (m Ω)	SATURATION CURRENT (A)	Size (LxWxH mm)	VENDOR
VLCF5020T	4.7	122	1.74	5.0 x 5.0 x 2.0	TDK
VLCF5014A	6.8	190	1.4	5.0 x 5.0 x 1.4	TDK
CDRH4D14/HP	4.7	140	1.4	4.8 x 4.8 x 1.5	Sumida
CDRH4D22/HP	10	144	1.5	5.0 x 5.0 x 2.4	Sumida

10.2.2.2 Input And Output Capacitor Selection

The output capacitor is mainly selected to meet output ripple and loop stability requirements. This ripple voltage is related to the capacitor's capacitance and its equivalent series resistance (ESR). Assuming a capacitor with zero ESR, the minimum capacitance needed for a given ripple can be calculated by

$$C_{out} = \frac{(V_{out} - V_{in})I_{out}}{V_{out} \times F_s \times V_{ripple}} \quad (13)$$

V_{ripple} = Peak to peak output ripple.

For $V_{IN} = 3.6V$, $V_{OUT} = 20V$, and $F_s = 1.2\text{ MHz}$, 0.1% ripple (20mV) would require 1.0 μ capacitor, however, the minimum recommended output capacitor for control loop stability is 4.7 μ F. The output capacitor value must be less than 30 μ F to ensure the startup current charges the output capacitor to the input voltage in less than 1.7ms. For this value, ceramic capacitors are a good choice for its size, cost and availability.

The additional output ripple component caused by ESR is calculated using:

$$V_{ripple_ESR} = I_{out} \times R_{ESR} \quad (14)$$

Due to its low ESR, V_{ripple_ESR} can be neglected for ceramic capacitors, but must be considered if tantalum or electrolytic capacitors are used.

During a load transient, the output capacitor at the output of the boost converter has to supply or absorb transient current before the inductor current ramps up its steady state value. Larger capacitors always help to reduce the voltage over and under shoot during a load transient. A larger capacitor also helps loop stability. Care must be taken when evaluating a ceramic capacitor's derating under dc bias, aging and AC signal. For example, larger form factor capacitors (in 1206 size) have their self resonant frequencies in the range of the switching frequency. So the effective capacitance is significantly lower. The DC bias can also significantly reduce capacitance. Ceramic capacitors can loss as much as 50% of its capacitance at its rated voltage. Therefore, almost leave margin on voltage rating to ensure adequate capacitance.

See [Device Support](#) for popular ceramic capacitor vendors.

10.2.3 Application Curves

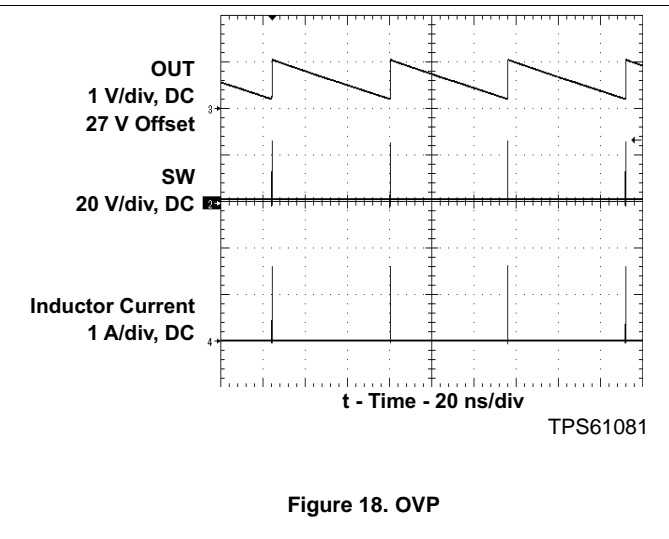
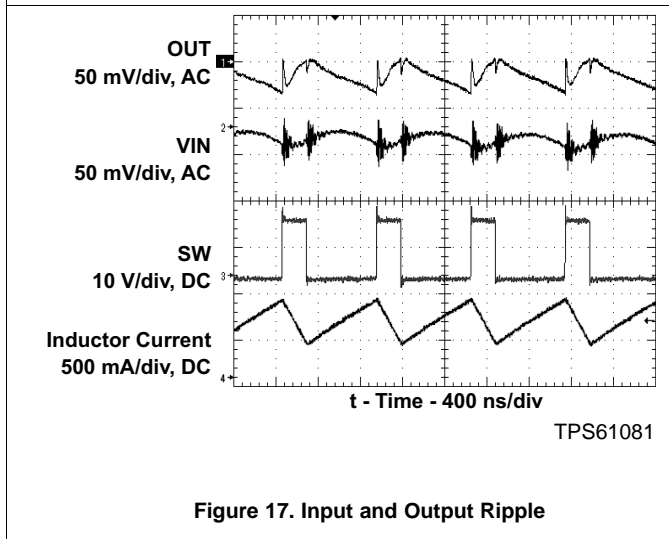
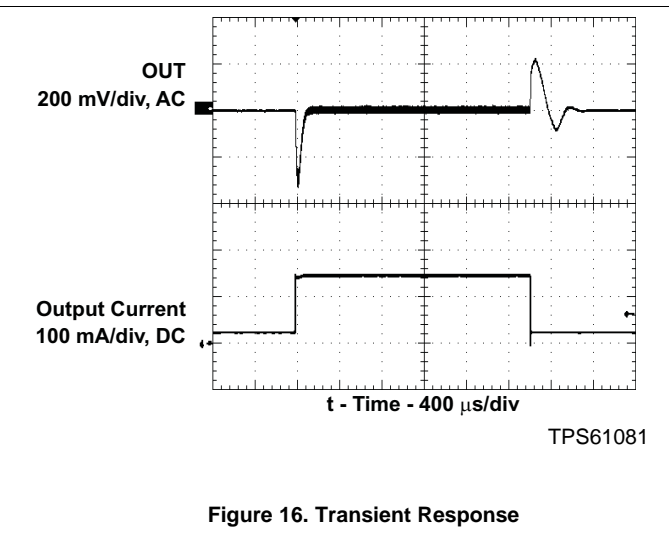
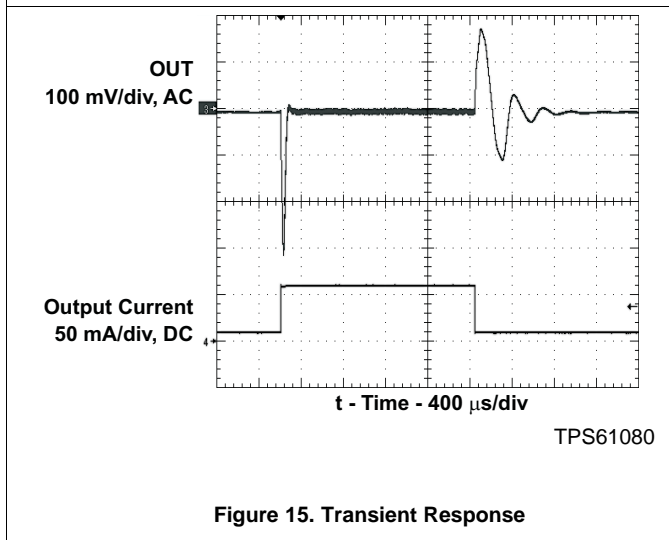
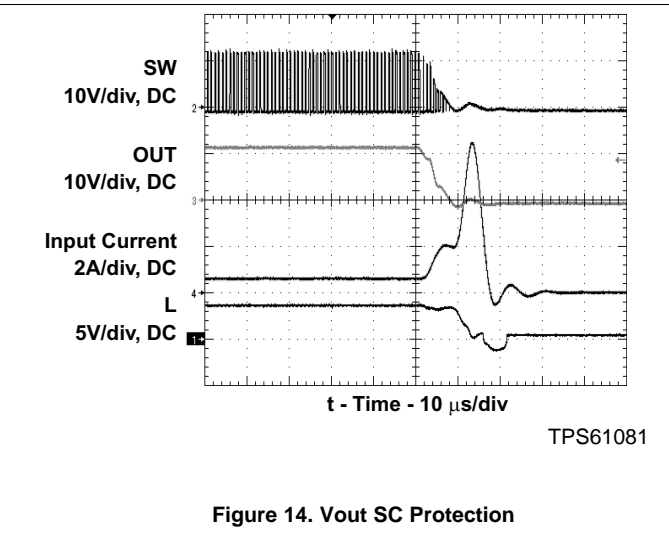
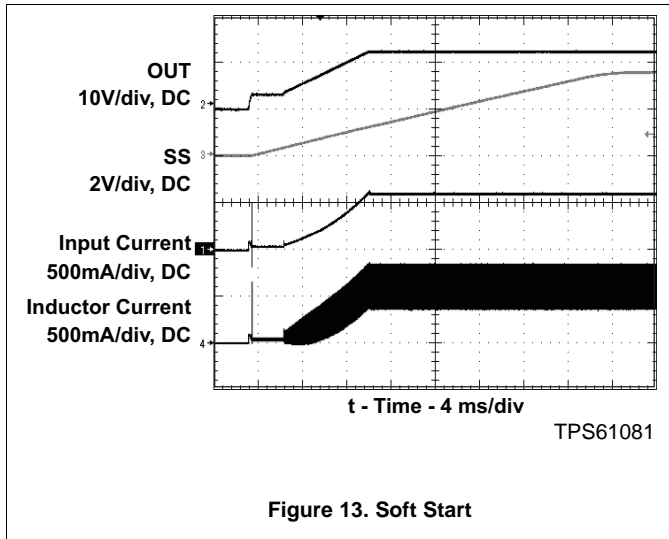

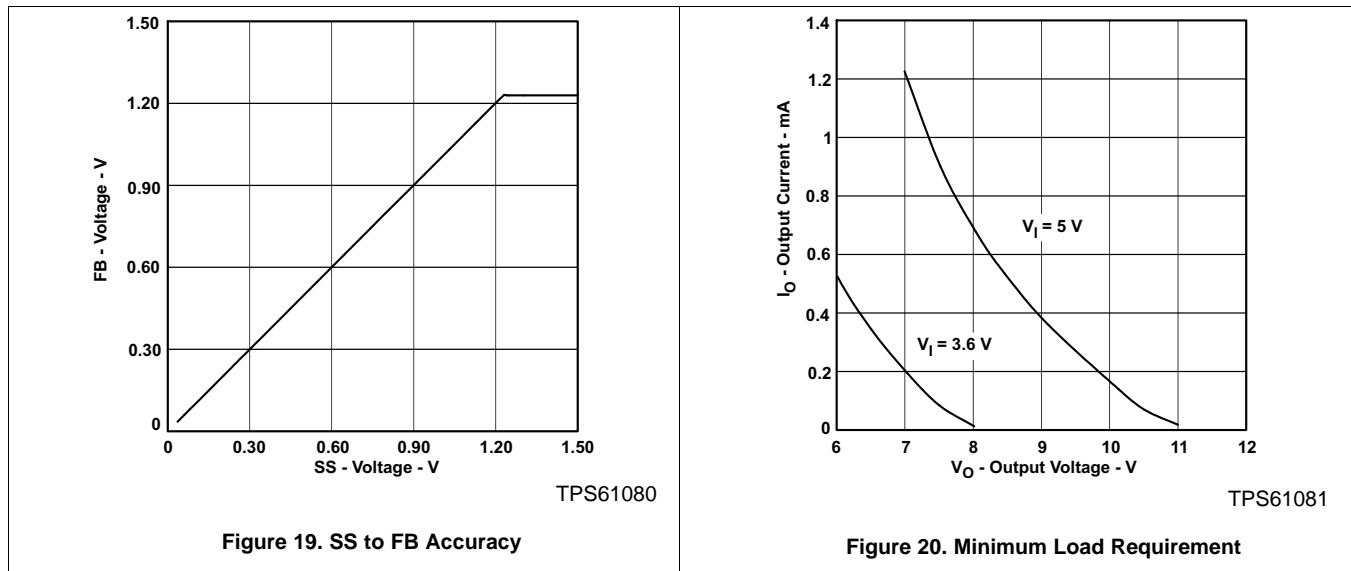

10.3 System Examples

10.3.1 Torch Light and Flash Light

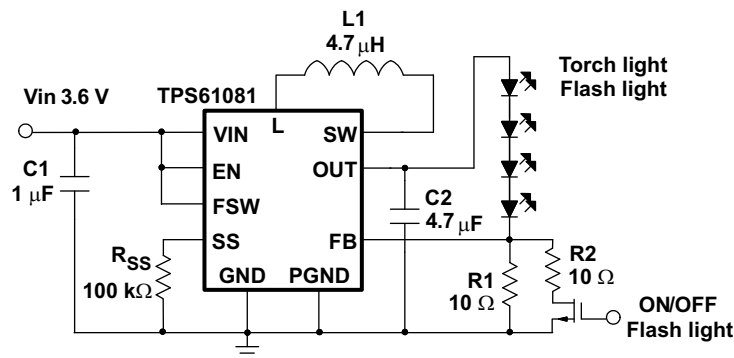

L1: TDK VLCF5020T- 4R7N1R7-1
 C1: Murata GRM188R60J105K; C2: Murata GRM219R61C475K

Figure 21. 50 mA Torch Light and 100 mA Flash Light

10.3.2 24Vout Output Converter

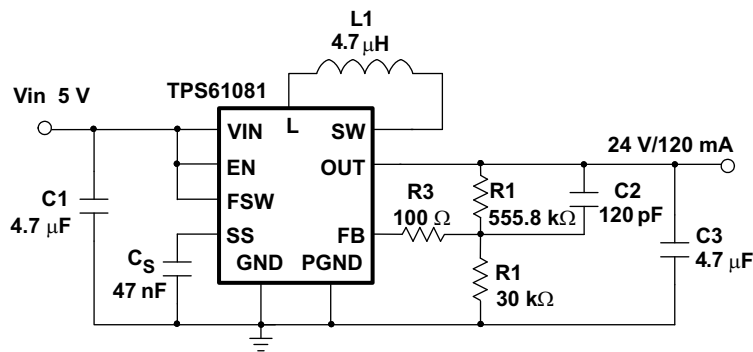

L1: TDK VLCF5020T- 4R1R7-1
 C1: Murata GRM188R60J475K; C3: Murata GRM55ER61H475K

Figure 22. 5 V to 24 V, 120 mA Step-Up DC-DC Converter

System Examples (continued)

10.3.3 30 WLEDs Driver in Media Factor Form Display

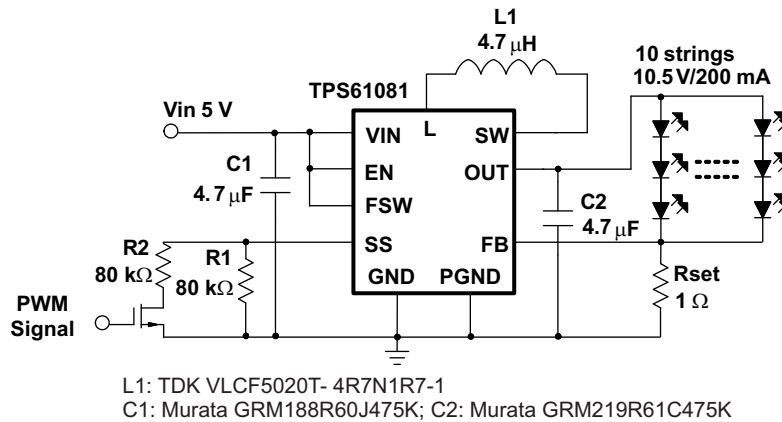

Figure 23. 30 WLEDs Driver in Media Factor Form Display

10.3.3.1 ±15 V Dual Output Converter

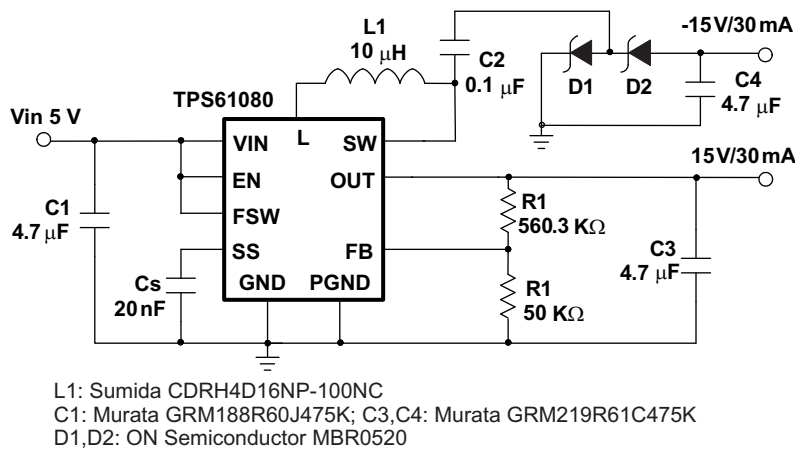

Figure 24. ±15 V Dual Output Converter

10.3.3.2 Step-Up DC-DC Converter with Output Doubler

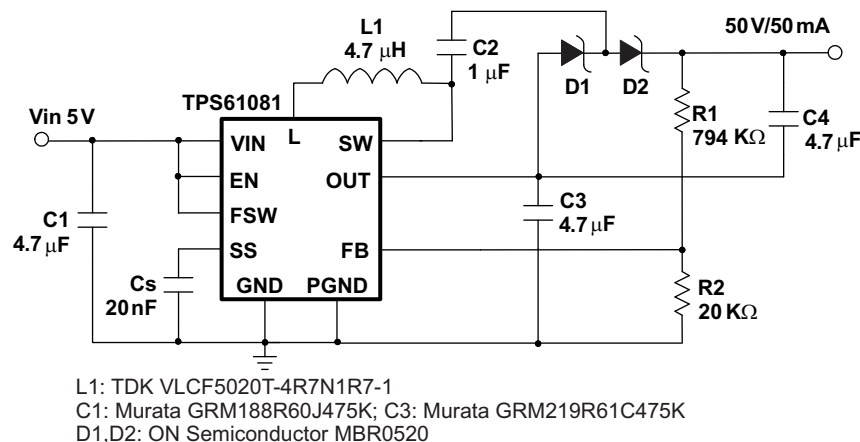

Figure 25. 5 V to 50 V, 50 mA Step-Up DC-DC Converter with Output Doubler

11 Power Supply Recommendations

The device is designed to operate from an input voltage supply range of TPS6108x's rating specification. This input supply must be well regulated. If the input supply is located more than a few inches from the converter, additional bulk capacitance may be required in addition to the ceramic bypass capacitors. An electrolytic or tantalum capacitor with a value of 47 μF is a typical choice.

12 Layout

12.1 Layout Guidelines

As for all switching power supplies, the layout is an important step in the design, especially for high current and high switching frequencies. If the layout is not carefully done, the regulator could show stability problems as well as EMI problems. Therefore, use wide and short traces for high current paths and for power ground tracks. Input capacitor needs not only to be close to the VIN, but also close to the GND pin to reduce the voltage ripple seen by the IC. The L and SW pins are conveniently located on the edge of the IC, therefore the inductor can be placed close to the IC. The output capacitor needs to be placed near the load to minimize ripple and maximize transient performance.

To minimize the effects of ground noise, use a common node for all power grounds that are connected to the PGND pin; and, a different one for signal ground tying to the GND pin. Connect two ground nodes together at the load if possible. This allows the GND pin to be close to the output ground for good DC regulation. Any voltage difference between these two nodes would be gained up by feedback divider on the output. It is also beneficial to have the ground of the output capacitor close to PGND because there is a large current between them. To lay out signal ground, it is recommended to use short traces separated from power ground traces.

12.2 Layout Example

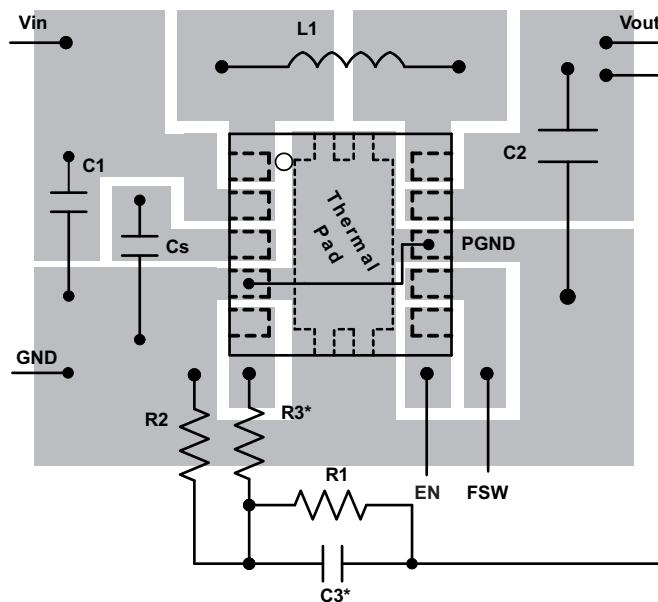

13 Device and Documentation Support

13.1 Device Support

13.1.1 Third-Party Products Disclaimer

TI'S PUBLICATION OF INFORMATION REGARDING THIRD-PARTY PRODUCTS OR SERVICES DOES NOT CONSTITUTE AN ENDORSEMENT REGARDING THE SUITABILITY OF SUCH PRODUCTS OR SERVICES OR A WARRANTY, REPRESENTATION OR ENDORSEMENT OF SUCH PRODUCTS OR SERVICES, EITHER ALONE OR IN COMBINATION WITH ANY TI PRODUCT OR SERVICE.

13.2 Related Links

The table below lists quick access links. Categories include technical documents, support and community resources, tools and software, and quick access to sample or buy.

Table 6. Related Links

PARTS	PRODUCT FOLDER	SAMPLE & BUY	TECHNICAL DOCUMENTS	TOOLS & SOFTWARE	SUPPORT & COMMUNITY
TPS61080	Click here	Click here	Click here	Click here	Click here
TPS61081	Click here	Click here	Click here	Click here	Click here

13.3 Trademarks

All trademarks are the property of their respective owners.

13.4 Electrostatic Discharge Caution



These devices have limited built-in ESD protection. The leads should be shorted together or the device placed in conductive foam during storage or handling to prevent electrostatic damage to the MOS gates.

13.5 Glossary

[SLYZ022](#) — *TI Glossary*.

This glossary lists and explains terms, acronyms, and definitions.

14 Mechanical, Packaging, and Orderable Information

The following pages include mechanical, packaging, and orderable information. This information is the most current data available for the designated devices. This data is subject to change without notice and revision of this document. For browser-based versions of this data sheet, refer to the left-hand navigation.

PACKAGING INFORMATION

Orderable Device	Status (1)	Package Type	Package Drawing	Pins	Package Qty	Eco Plan (2)	Lead finish/ Ball material (6)	MSL Peak Temp (3)	Op Temp (°C)	Device Marking (4/5)	Samples
TPS61080DRCR	ACTIVE	VSON	DRC	10	3000	RoHS & Green	NIPDAU	Level-2-260C-1 YEAR	-40 to 85	BCN	Samples
TPS61080DRCT	ACTIVE	VSON	DRC	10	250	RoHS & Green	NIPDAU	Level-2-260C-1 YEAR	-40 to 85	BCN	Samples
TPS61080DRCTG4	ACTIVE	VSON	DRC	10	250	RoHS & Green	NIPDAU	Level-2-260C-1 YEAR	-40 to 85	BCN	Samples
TPS61081DRCR	ACTIVE	VSON	DRC	10	3000	RoHS & Green	NIPDAU	Level-2-260C-1 YEAR	-40 to 85	BCO	Samples
TPS61081DRCRG4	ACTIVE	VSON	DRC	10	3000	RoHS & Green	NIPDAU	Level-2-260C-1 YEAR	-40 to 85	BCO	Samples
TPS61081DRCT	ACTIVE	VSON	DRC	10	250	RoHS & Green	NIPDAU	Level-2-260C-1 YEAR	-40 to 85	BCO	Samples
TPS61081DRCTG4	ACTIVE	VSON	DRC	10	250	RoHS & Green	NIPDAU	Level-2-260C-1 YEAR	-40 to 85	BCO	Samples

(1) The marketing status values are defined as follows:

ACTIVE: Product device recommended for new designs.

LIFEBUY: TI has announced that the device will be discontinued, and a lifetime-buy period is in effect.

NRND: Not recommended for new designs. Device is in production to support existing customers, but TI does not recommend using this part in a new design.

PREVIEW: Device has been announced but is not in production. Samples may or may not be available.

OBSOLETE: TI has discontinued the production of the device.

(2) **RoHS:** TI defines "RoHS" to mean semiconductor products that are compliant with the current EU RoHS requirements for all 10 RoHS substances, including the requirement that RoHS substance do not exceed 0.1% by weight in homogeneous materials. Where designed to be soldered at high temperatures, "RoHS" products are suitable for use in specified lead-free processes. TI may reference these types of products as "Pb-Free".

RoHS Exempt: TI defines "RoHS Exempt" to mean products that contain lead but are compliant with EU RoHS pursuant to a specific EU RoHS exemption.

Green: TI defines "Green" to mean the content of Chlorine (Cl) and Bromine (Br) based flame retardants meet JS709B low halogen requirements of <=1000ppm threshold. Antimony trioxide based flame retardants must also meet the <=1000ppm threshold requirement.

(3) MSL, Peak Temp. - The Moisture Sensitivity Level rating according to the JEDEC industry standard classifications, and peak solder temperature.

(4) There may be additional marking, which relates to the logo, the lot trace code information, or the environmental category on the device.

(5) Multiple Device Markings will be inside parentheses. Only one Device Marking contained in parentheses and separated by a "~" will appear on a device. If a line is indented then it is a continuation of the previous line and the two combined represent the entire Device Marking for that device.

⁽⁶⁾ Lead finish/Ball material - Orderable Devices may have multiple material finish options. Finish options are separated by a vertical ruled line. Lead finish/Ball material values may wrap to two lines if the finish value exceeds the maximum column width.

Important Information and Disclaimer:The information provided on this page represents TI's knowledge and belief as of the date that it is provided. TI bases its knowledge and belief on information provided by third parties, and makes no representation or warranty as to the accuracy of such information. Efforts are underway to better integrate information from third parties. TI has taken and continues to take reasonable steps to provide representative and accurate information but may not have conducted destructive testing or chemical analysis on incoming materials and chemicals. TI and TI suppliers consider certain information to be proprietary, and thus CAS numbers and other limited information may not be available for release.

In no event shall TI's liability arising out of such information exceed the total purchase price of the TI part(s) at issue in this document sold by TI to Customer on an annual basis.

TAPE AND REEL INFORMATION

QUADRANT ASSIGNMENTS FOR PIN 1 ORIENTATION IN TAPE

*All dimensions are nominal

Device	Package Type	Package Drawing	Pins	SPQ	Reel Diameter (mm)	Reel Width W1 (mm)	A0 (mm)	B0 (mm)	K0 (mm)	P1 (mm)	W (mm)	Pin1 Quadrant
TPS61080DRCR	VSON	DRC	10	3000	330.0	12.4	3.3	3.3	1.1	8.0	12.0	Q2
TPS61080DRCT	VSON	DRC	10	250	180.0	12.4	3.3	3.3	1.1	8.0	12.0	Q2
TPS61081DRCR	VSON	DRC	10	3000	330.0	12.4	3.3	3.3	1.1	8.0	12.0	Q2
TPS61081DRCT	VSON	DRC	10	250	180.0	12.4	3.3	3.3	1.1	8.0	12.0	Q2

TAPE AND REEL BOX DIMENSIONS

*All dimensions are nominal

Device	Package Type	Package Drawing	Pins	SPQ	Length (mm)	Width (mm)	Height (mm)
TPS61080DRCR	VSON	DRC	10	3000	853.0	449.0	35.0
TPS61080DRCT	VSON	DRC	10	250	210.0	185.0	35.0
TPS61081DRCR	VSON	DRC	10	3000	853.0	449.0	35.0
TPS61081DRCT	VSON	DRC	10	250	210.0	185.0	35.0

GENERIC PACKAGE VIEW

DRC 10

VSON - 1 mm max height

3 x 3, 0.5 mm pitch

PLASTIC SMALL OUTLINE - NO LEAD

This image is a representation of the package family, actual package may vary.
Refer to the product data sheet for package details.



4226193/A

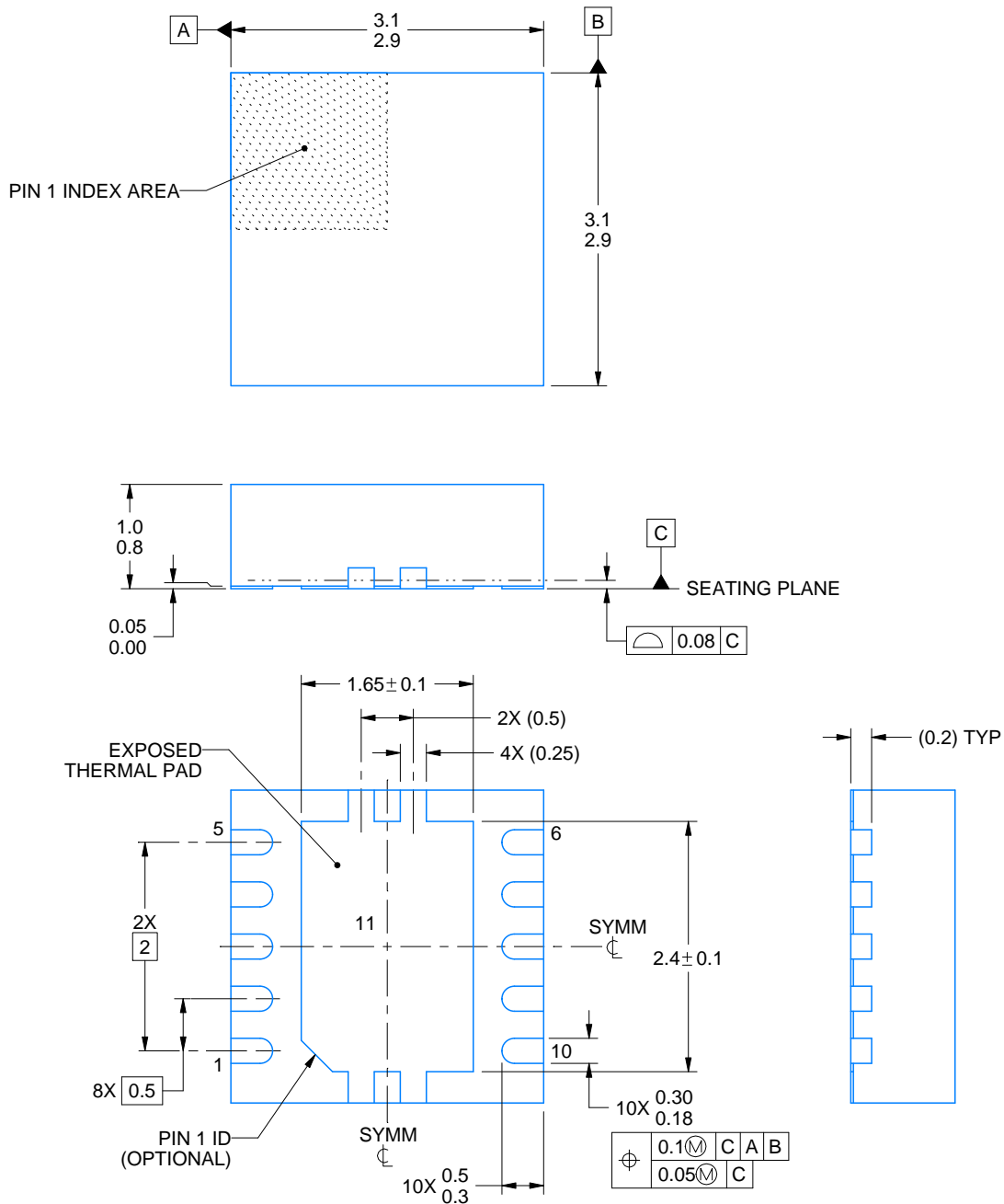

4218878/B 07/2018

NOTES:

1. All linear dimensions are in millimeters. Any dimensions in parenthesis are for reference only. Dimensioning and tolerancing per ASME Y14.5M.
2. This drawing is subject to change without notice.
3. The package thermal pad must be soldered to the printed circuit board for optimal thermal and mechanical performance.

EXAMPLE BOARD LAYOUT

DRC0010J

VSON - 1 mm max height

PLASTIC SMALL OUTLINE - NO LEAD



LAND PATTERN EXAMPLE
EXPOSED METAL SHOWN
SCALE:20X



SOLDER MASK DETAILS

4218878/B 07/2018

NOTES: (continued)

4. This package is designed to be soldered to a thermal pad on the board. For more information, see Texas Instruments literature number SLUA271 (www.ti.com/lit/slua271).
5. Vias are optional depending on application, refer to device data sheet. If any vias are implemented, refer to their locations shown on this view. It is recommended that vias under paste be filled, plugged or tented.

EXAMPLE STENCIL DESIGN

DRC0010J

VSON - 1 mm max height

PLASTIC SMALL OUTLINE - NO LEAD



SOLDER PASTE EXAMPLE
BASED ON 0.125 mm THICK STENCIL

EXPOSED PAD 11:
80% PRINTED SOLDER COVERAGE BY AREA
SCALE:25X

4218878/B 07/2018

NOTES: (continued)

6. Laser cutting apertures with trapezoidal walls and rounded corners may offer better paste release. IPC-7525 may have alternate design recommendations.

IMPORTANT NOTICE AND DISCLAIMER

TI PROVIDES TECHNICAL AND RELIABILITY DATA (INCLUDING DATASHEETS), DESIGN RESOURCES (INCLUDING REFERENCE DESIGNS), APPLICATION OR OTHER DESIGN ADVICE, WEB TOOLS, SAFETY INFORMATION, AND OTHER RESOURCES "AS IS" AND WITH ALL FAULTS, AND DISCLAIMS ALL WARRANTIES, EXPRESS AND IMPLIED, INCLUDING WITHOUT LIMITATION ANY IMPLIED WARRANTIES OF MERCHANTABILITY, FITNESS FOR A PARTICULAR PURPOSE OR NON-INFRINGEMENT OF THIRD PARTY INTELLECTUAL PROPERTY RIGHTS.

These resources are intended for skilled developers designing with TI products. You are solely responsible for (1) selecting the appropriate TI products for your application, (2) designing, validating and testing your application, and (3) ensuring your application meets applicable standards, and any other safety, security, or other requirements. These resources are subject to change without notice. TI grants you permission to use these resources only for development of an application that uses the TI products described in the resource. Other reproduction and display of these resources is prohibited. No license is granted to any other TI intellectual property right or to any third party intellectual property right. TI disclaims responsibility for, and you will fully indemnify TI and its representatives against, any claims, damages, costs, losses, and liabilities arising out of your use of these resources.

TI's products are provided subject to TI's Terms of Sale (<https://www.ti.com/legal/termsofsale.html>) or other applicable terms available either on [ti.com](https://www.ti.com) or provided in conjunction with such TI products. TI's provision of these resources does not expand or otherwise alter TI's applicable warranties or warranty disclaimers for TI products.

Mailing Address: Texas Instruments, Post Office Box 655303, Dallas, Texas 75265
Copyright © 2021, Texas Instruments Incorporated