

# HI0603N330R-10

## PHYSICAL DIMENSIONS:

A	1.60 [.063]	+ 0.15	[.006]
B	0.80 [.031]	+ 0.15	[.006]
C	0.80 [.031]	+ 0.15	[.006]
D	0.36 [.014]	+ 0.15	[.006]

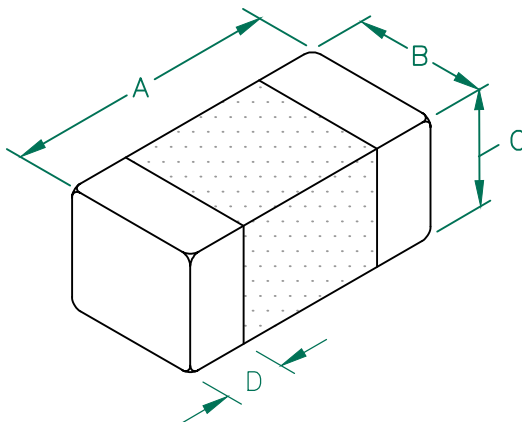

## ELECTRICAL CHARACTERISTICS:

Z @ 100MHz (Ω)	DCR (Ω)	Rated Current
Nominal	33.0	
Minimum	24.7	
Maximum	41.3	0.025
		3000 mA

## NOTES: UNLESS OTHERWISE SPECIFIED

1. TAPED AND REELED per CURRENT EIA SPECIFICATIONS 7" REELS, 4000 PCS/REEL.
2. TERMINATION FINISH IS 100% TIN.
3. COMPONENTS SHOULD BE ADEQUATELY PREHEATED BEFORE SOLDERING.
4. OPERATING TEMPERATURE TEMP: -40°C~+125°C. (INCLUDING SELF-HEATING)

Z vs FREQUENCY  
IMPEDANCE UNDER DC BIAS

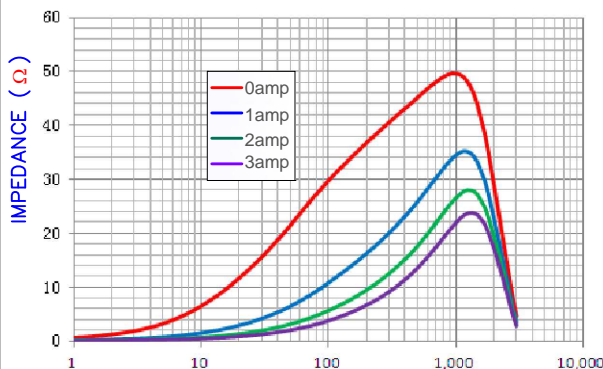

FREQUENCY (MHz)  
|Z|, R, AND X vs. FREQUENCY

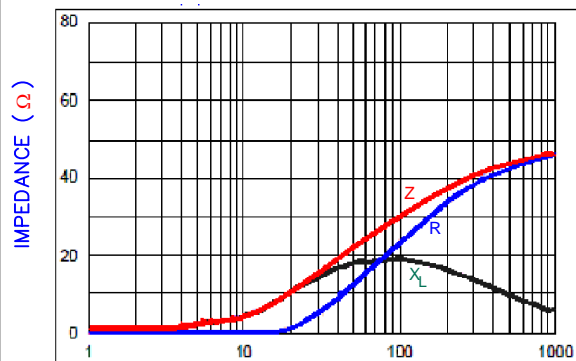

FREQUENCY (MHz)

Z R X<sub>L</sub>

## LAND PATTERNS FOR REFLOW SOLDERING

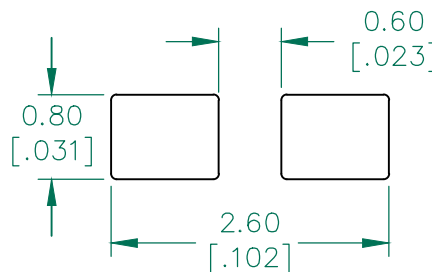

(For wave soldering, add 0.762 [.030] to this dimension)

## RECOMMENDED SOLDERING CONDITIONS

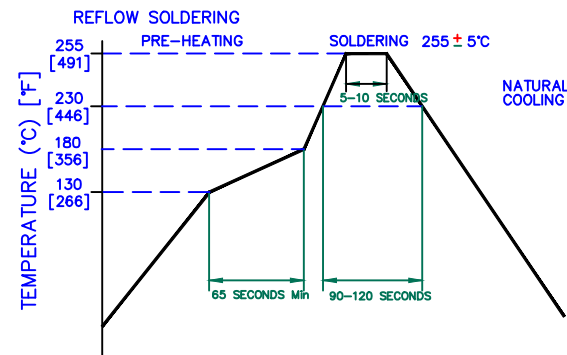

DIMENSIONS ARE IN mm [INCHES].				This print is the property of Laird Tech. and is loaned in confidence subject to return upon request and with the understanding that no copies shall be made without the written consent of Laird Tech. All rights to design or invention are reserved.			
PROJECT/PART NUMBER:				REV			
C UPDATE LAIRD LOGO AND NOTES 4				C			
B ADD DC BIAS CURVE				PART TYPE: CO-FIRE			
A ORIGINAL DRAFT				DRAWN BY: QU			
REV				DATE: 12/06/12			
DESCRIPTION				SCALE: -			
DATE: 08/05/13				SHEET: 1 of 1			
QU				DATE: 12/06/12			
QU				CAD # HI0603N330R-10-C			
QU				TOOL # -			
QU				QU			

