

4

3

2

1

THIS DRAWING IS UNPUBLISHED. RELEASED FOR PUBLICATION
© COPYRIGHT ALL RIGHTS RESERVED.

LOC	DIST	REVISIONS			
P	LTR	DESCRIPTION	DATE	DWN	APVD
	A1	ECR-16-009824	28JUL2016	GK	SD

REPLACED BY OCEAN STYLE APPLICATOR PART NUMBER 2836284-1

FOR REPLACEMENT PARTS FOR APPLICATOR 1426569
REFER TO ADDITIONAL PAGE(S). SPARE PARTS KIT (IF LISTED)
WILL REMAIN AVAILABLE.

THE REPLACEMENT OCEAN STYLE APPLICATOR HAS THE
SAME TERMINATOR/PRESS INTERFACE AS APPLICATOR
1426569

THIS DRAWING IS A CONTROLLED DOCUMENT.		DWN	GOPALAKRISHNA HV		 TE Connectivity
DIMENSIONS:		CHK	GOPALAKRISHNA HV		
TOLERANCES UNLESS OTHERWISE SPECIFIED:		APVD	STOUGH DALE		NAME SIDE FEED HDI APPLICATOR
0 PLC ±		PRODUCT SPEC			
1 PLC ±		APPLICATION SPEC			SIZE A3
2 PLC ±		WEIGHT	CAGE CODE	DRAWING NO	
3 PLC ±		MATERIAL	FINISH	C- 1426569	
4 PLC ±				RESTRICTED TO	
ANGLES ±		CUSTOMER DRAWING		SCALE	SHEET 1 OF 2
FINISH				REV	A1

PART NUMBER	REV	TERMINATOR	FEED TYPE	DESCRIPTION
1426569-1	A	LEADMAKER	MECH POST FEED	CUTS CARRIER
1426569-2	A	BENCH	MECH PRE FEED	CUTS CARRIER
1426569-6	A	LEADMAKER	MECH POST FEED	CONTINUOUS CARRIER
7-1426569-1	A	LEADMAKER	MECH POST FEED	-1 AND SPARE PARTS
7-1426569-2	A	BENCH	MECH PRE FEED	-2 AND SPARE PARTS
7-1426569-6	A	LEADMAKER	MECH POST FEED	-6 AND SPARE PARTS
7-1426569-7	A	-	-	SPARE PARTS KIT

CRIMP DATA		TYCO TERMINAL		TYCO CRIMP SPECS	
TERMINAL NAME: TAB,FASTON, .187 SERIES					
CRIMP	SIZE	TYPE	RANGE		
WIRE	2.29 [.090 IN]	F	22-18 AWG		
INSUL	3.94 [.155 IN]	O	2.03-3.05 [.080-.120 IN]		
WIRE STRIP LENGTH	4.40-5.16 [.173-.203 IN]		APPL INSTRUCTIONS 408-8322		
TERMINAL APPL SPEC 114-2036			FEED 11.18 [.440 IN]		
TERMINALS APPLIED					
42490	-	-	-	-	-
63857	-	-	-	-	-
-	-	-	-	-	-
-	-	-	-	-	-
-	-	-	-	-	-
WIRE SIZE	CRIMP HEIGHT	PIN PN & LENGTH [IN]			
18 AWG	1.57 ±0.05 [.062 ±.002 IN]	1-354779-3 [.3055]			
20 AWG	1.52 ±0.05 [.060 ±.002 IN]	1-354779-8 [.3080]			
22 AWG	1.45 ±0.05 [.057 ±.002 IN]	2-354779-4 [.3110]			

- ▲ RECOMMENDED SPARE PARTS.
- 2. GREASE RAM, CAM, CAM FOLLOWER AND FEED ROD LIGHTLY.
- ▲ CERTAIN TERMINALS REQUIRE LUBRICATION. REFER TO THE APPLICATOR INSTRUCTION SHEET FOR MORE INFORMATION.
- 4. LUBRICATE DAILY PER THE APPLICATOR INSTRUCTION SHEET SUPPLIED WITH THE APPLICATOR.
- ▲ APPL. SPEC 114-2036 TO BE USED FOR ALL OTHER CRIMP INFORMATION NOT STATED ABOVE.

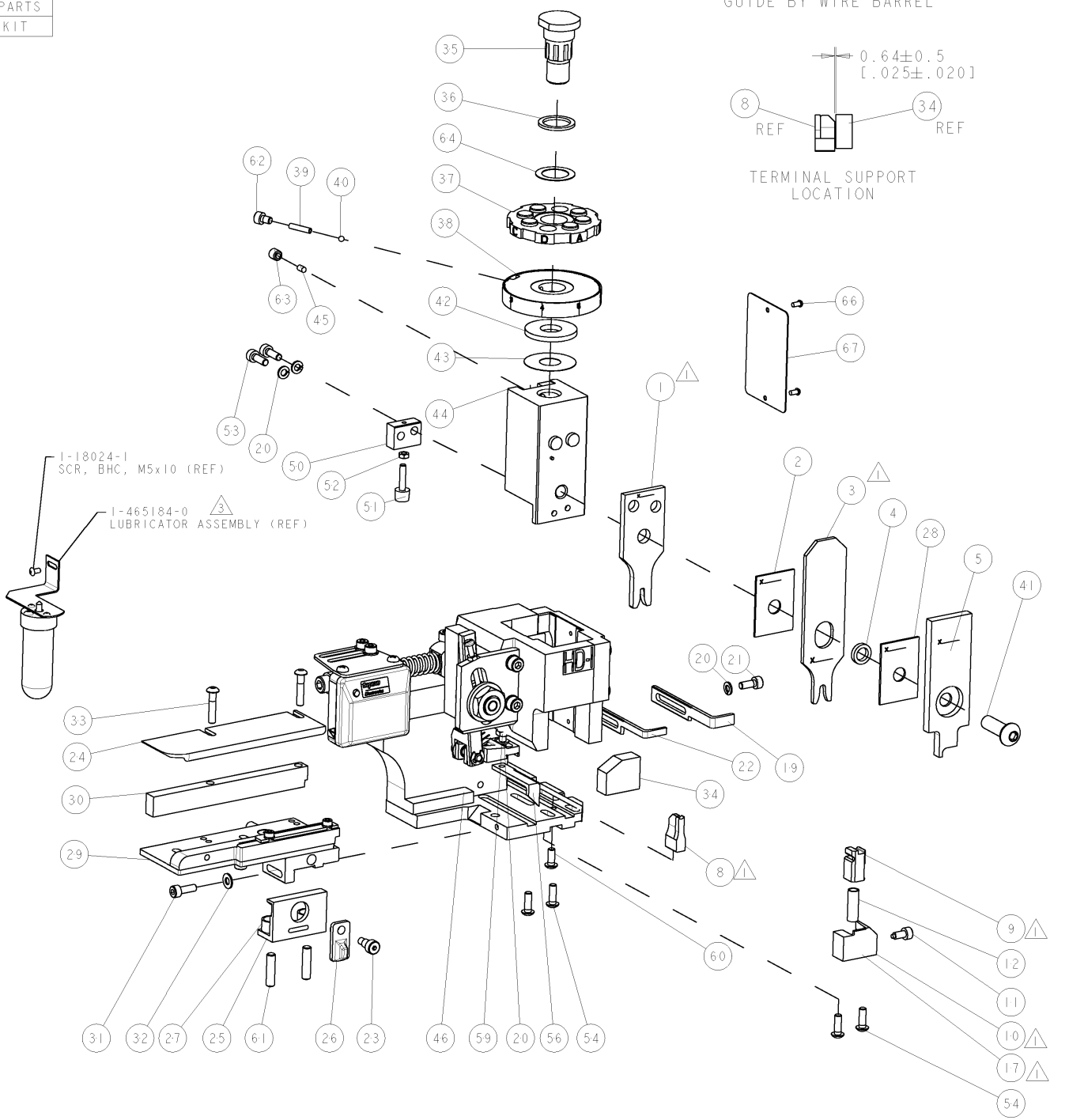
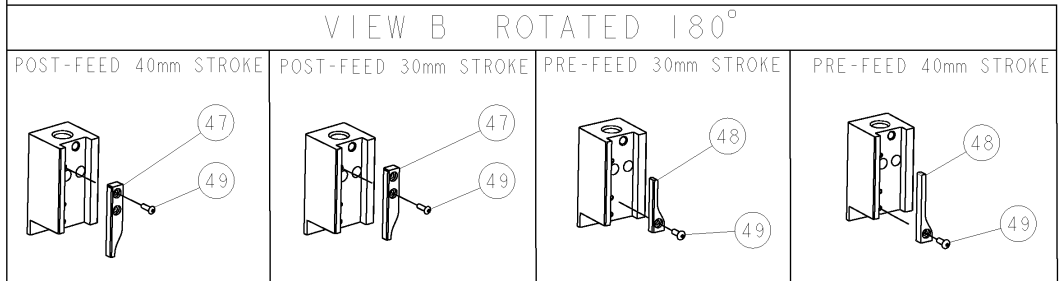

PART NO	DESCRIPTION	ITEM NO
-77		84
-76		83
-72		82
-71		81
-6		80
-2		79
-1		78
		77
		76
		75
		74

REVOLUTIONS		DATE	OWN	APPR
1	SEE ECO-05-012970	04NOV2005	LJL	MC

ITEM NO	DESCRIPTION	ITEM NO
-	-	73
-	-	72
-	-	71
-	-	70
-	-	69
-	-	68
-	-	67
-	-	66
-	-	65
-	-	64
-	-	63
-	-	62
-	-	61
-	-	60
-	-	59
-	-	58
-	-	57
-	-	56
-	-	55
-	-	54
-	-	53
-	-	52
-	-	51
-	-	50
-	-	49
-	-	48
-	-	47
-	-	46
-	-	45
-	-	44
-	-	43
-	-	42
-	-	41
-	-	40
-	-	39
-	-	38
-	-	37
-	-	36
-	-	35
-	-	34
-	-	33
-	-	32
-	-	31
-	-	30
-	-	29
-	-	28
-	-	27
-	-	26
-	-	25
-	-	24
-	-	23
-	-	22
-	-	21
-	-	20
-	-	19
-	-	18
-	-	17
-	-	16
-	-	15
-	-	14
-	-	13
-	-	12
-	-	11
-	-	10
-	-	9
-	-	8
-	-	7
-	-	6
-	-	5
-	-	4
-	-	3
-	-	2
-	-	1

PART NO	DESCRIPTION	ITEM NO
-77		84
-76		83
-72		82
-71		81
-6		80
-2		79
-1		78
		77
		76
		75
		74

SET UP GAGE
458637-3