

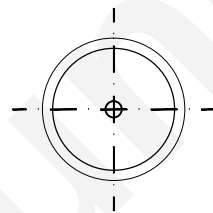

PART NO.	BASE TYPE	DESIGN VOLTS	DESIGN WATTS	LUMENS	FILAMENT TYPE	AVERAGE LIFE HOURS	REVISIONS			
							REV #	DESCRIPTION	DATE	APPROVED
6461	FESTOON CAP (SV8.5-8)	12.0V	10±10%	105±20%	C-8	200	1	ISSUED	07/11/2001	E.S.
							2	SPECIFICATION UPDATED	05/21/2009	M.L.
							3	REDRAWN TO ADD VIEWS	04/04/2016	R.M.

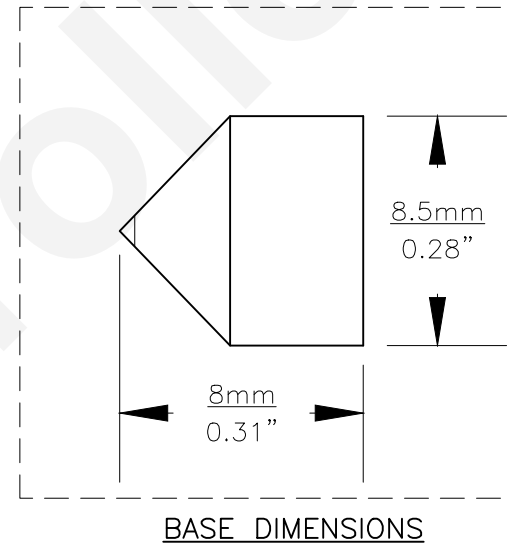

BASE BOTTOM VIEW

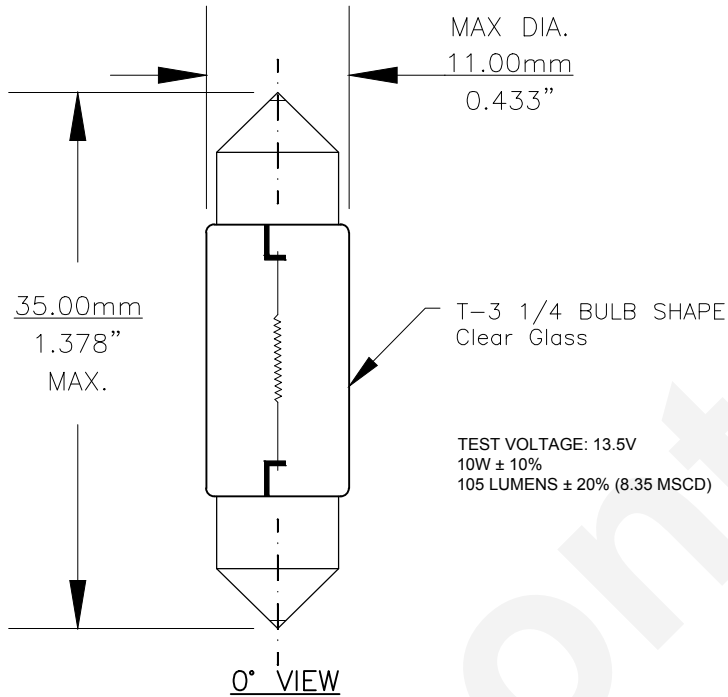

Note: Made according to SAE specifications

UNLESS OTHERWISE SPECIFIED: DIMENSIONS ARE IN INCHES TOLERANCES		CEC INDUSTRIES LTD			
DECIMALS .XX ± .05		599 BOND STREET		LINCOLNSHIRE, IL 60069	
ANGULAR .XXX ± .010		TITLE LIGHT BULB NO. 6461			
FRACTIONAL ± 1/64		DATE 07/11/2001		REV 3	
DRAWN ELIZABETH SONANES	CHECKED	SIZE A	FSCM NO.	DWG NO. 6461	REV 3
DESIGN	MATERIAL	SCALE	PLOT SCALE	SHEET 1 OF 1	
		FILE 6461.pdf	DRAWING NOT TO SCALE		