

4

3

2

1

THIS DRAWING IS UNPUBLISHED.
 VERTRAULICHE UNVERÖFFENTLICHTE ZEICHNUNG

RELEASED FOR PUBLICATION
 FREI FUER VERÖFFENTLICHUNG

© COPYRIGHT - By -

ALL RIGHTS RESERVED.
 ALLE RECHTE VORBEHALTEN

LOC	DIST	P	LTR	REVISIONS ÄNDERUNGEN	DATE	DWN	APVD
A1	-			DESCRIPTION BESCHREIBUNG			
			C1	REVISED PER ECO-11-005150	21MAR11	RK	HMR

WAR NR.
 VERWENDET FÜR
 PASSEND ZU 967325,967326
 967402,967447

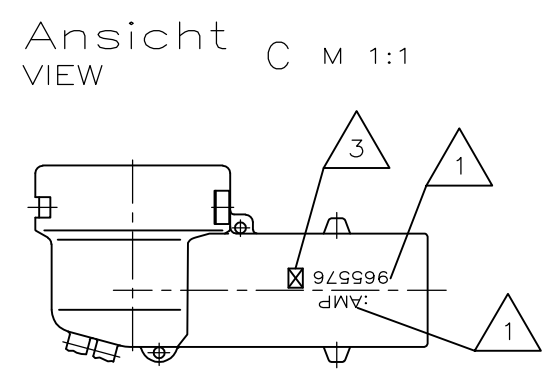
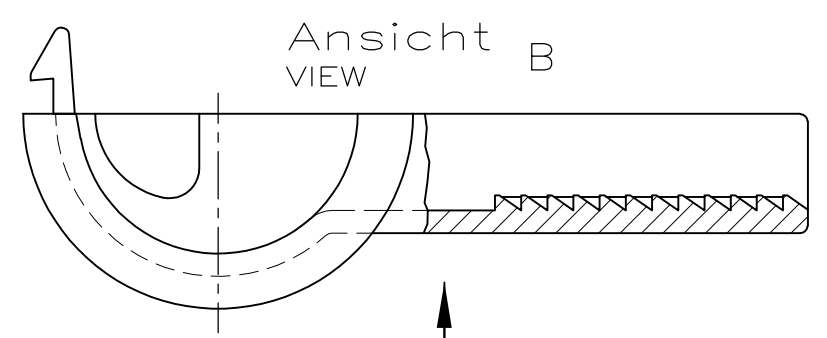
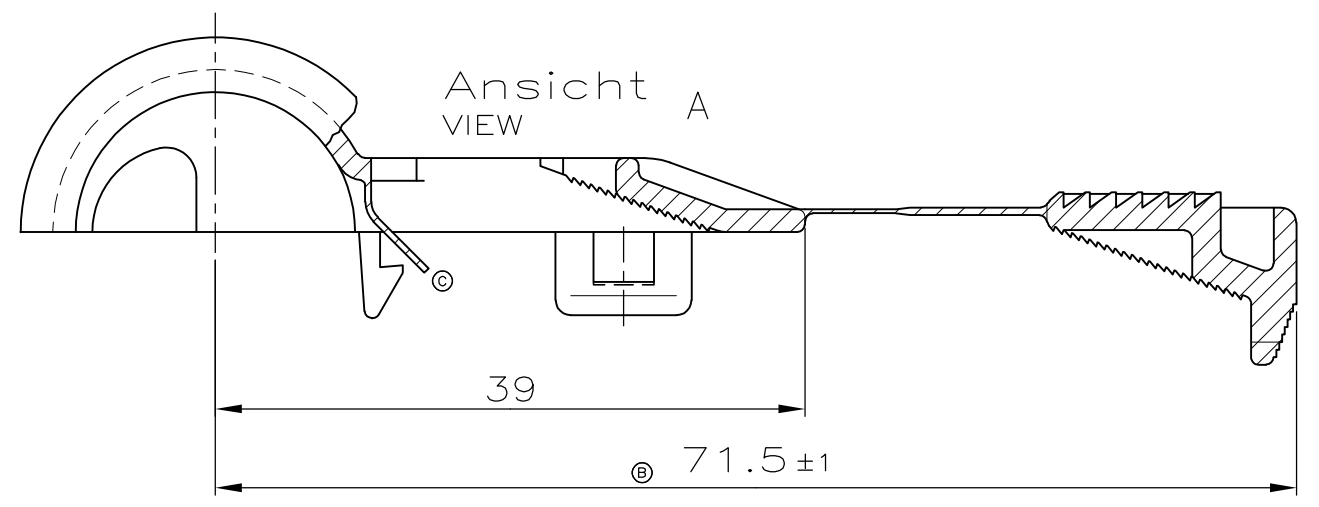
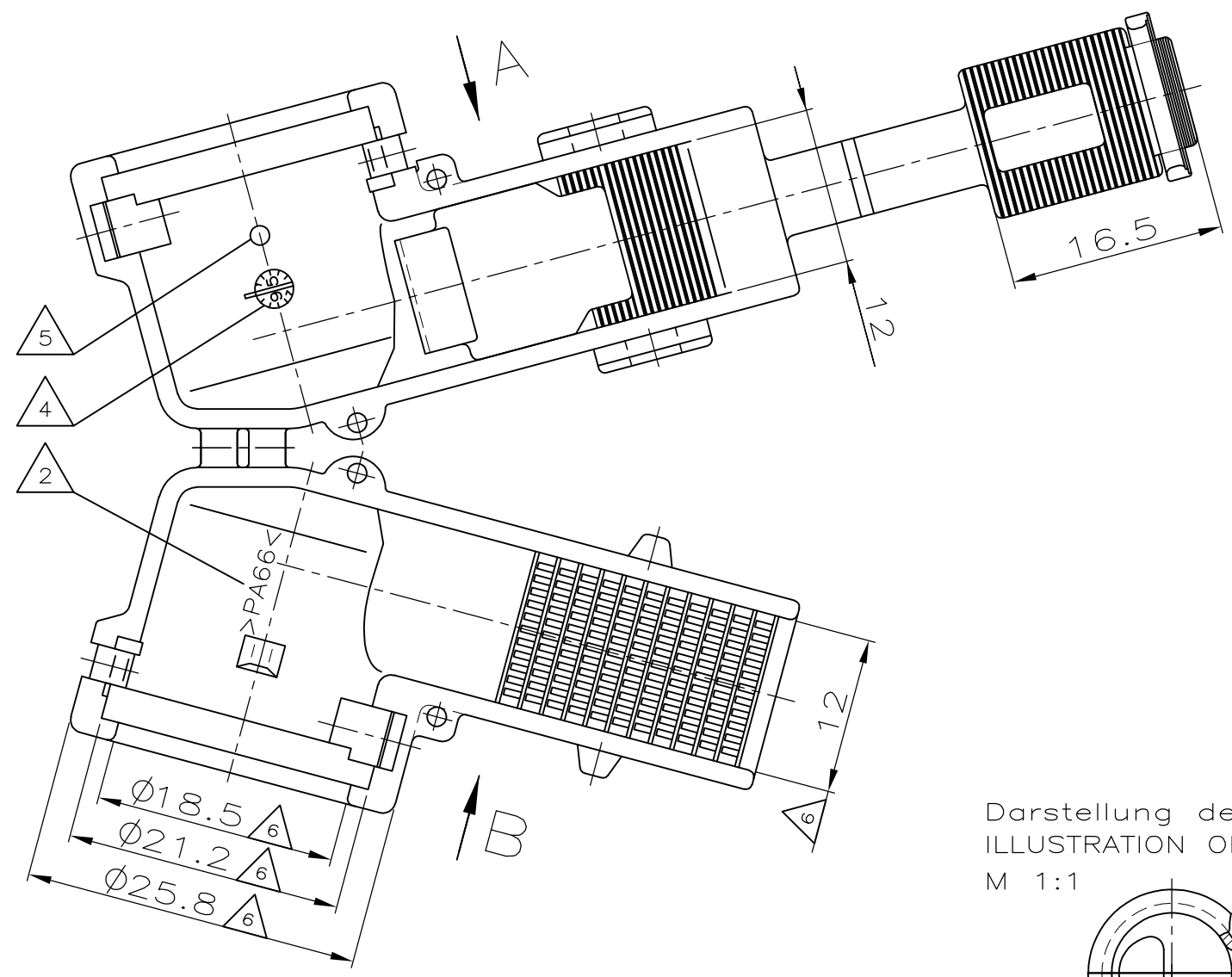

Darstellung der verrasteten Kappe
 ILLUSTRATION OF ASSEMBLED CAP
 M 1:1

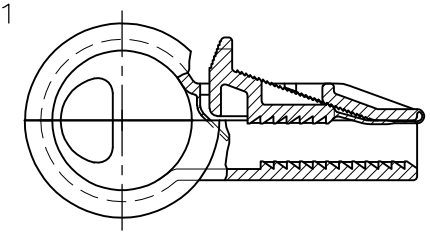

Bemerkungen
 NOTES

- 1 AMP-Logo und AMP-Nummer
AMP LOGO AND AMP NUMBER
- 2 Werkstoffkennzeichnung
MATERIAL MARKING
- 3 Werkzeugaenderungsindex
REVISION OF THE MOULD
- 4 Produktionsdatum
PRODUCTION DATE
- 5 Nestmarkierung
CAVITY MARKING
- 6 Verzug vom Nennmaß bis -0.8mm zugelassen
WARPAGE FROM NOM. DIMENSION UP TO -0.8MM ALLOWED

965576-1	-	-	Kappe 90° m. variabler Klemmung CAP 90° FOR VARIABLE FIXING	PA 66	schwarz/BLACK
Bestell-Nr. ORDER-NR.	POS.	Stück QTY	Benennung Einzelteil DESCRIPTION SINGLE PART	Werkstoff MATERIAL	Oberfläche/SURFACE Farbe/COLOUR

THIS DRAWING IS A CONTROLLED DOCUMENT. DIESE ZEICHNUNG IST EIN KONTROLLIERTES DOKUMENT.		DWN J.Granzow 07.06.95	TE Connectivity Kappe 90DEG mit variabler Klemmung CAP 90DEG FOR VARIABLE FIXING		
DIMENSIONS: MASSE/MAßE: mm		CHK J.Hass 08.06.95			
TOLERANCES UNLESS OTHERWISE SPECIFIED: ALLGEMEINTOLERANZEN		APVD -	NAME		
0 PLC ± - 1 PLC ± 0.4 2 PLC ± - 3 PLC ± - 4 PLC ± - ANGLES / WINKEL ± 2'		PRODUCT SPEC PRODUKTSPEZ. -	SIZE		
MATERIAL		APPLICATION SPEC. VERARBEITUNGSSPEZ. -	CAGE CODE	DRAWING NO ZEICHNUNGS-NR.	RESTRICTED TO NUR FUER
FINISH/OBERFLAECHE/FARBE		WEIGHT GEWICHT	A300779	G-965576	-
CUSTOMER DRAWING/KUNDENZEICHNUNG			SCALE MASSTAB 2:1	SHEET BLATT 1 OF 1	REV C1