

THIS IS A C.A.D. GENERATED DRAWING
DO NOT MAKE MANUAL REVISIONS TO MASTER.



* UNLESS OTHERWISE SPECIFIED TOLERANCES
ON DECIMAL IS:

UNIT: MM			
DIM	TOL	DIM	TOL
X.	±0.15	X°.	±2.0°
X.X	±0.10	X.X°	±1.0°
X.XX	±0.05	X.XX°	±0.5°
X.XXX	±0.03	X.XXX°	±0.3°

ISSUE NUMBER

ORIGINAL ①

ADD NOTE 2 & 3.
ADD UNPLATED P/N ②
Peter Deng JUN.26/19

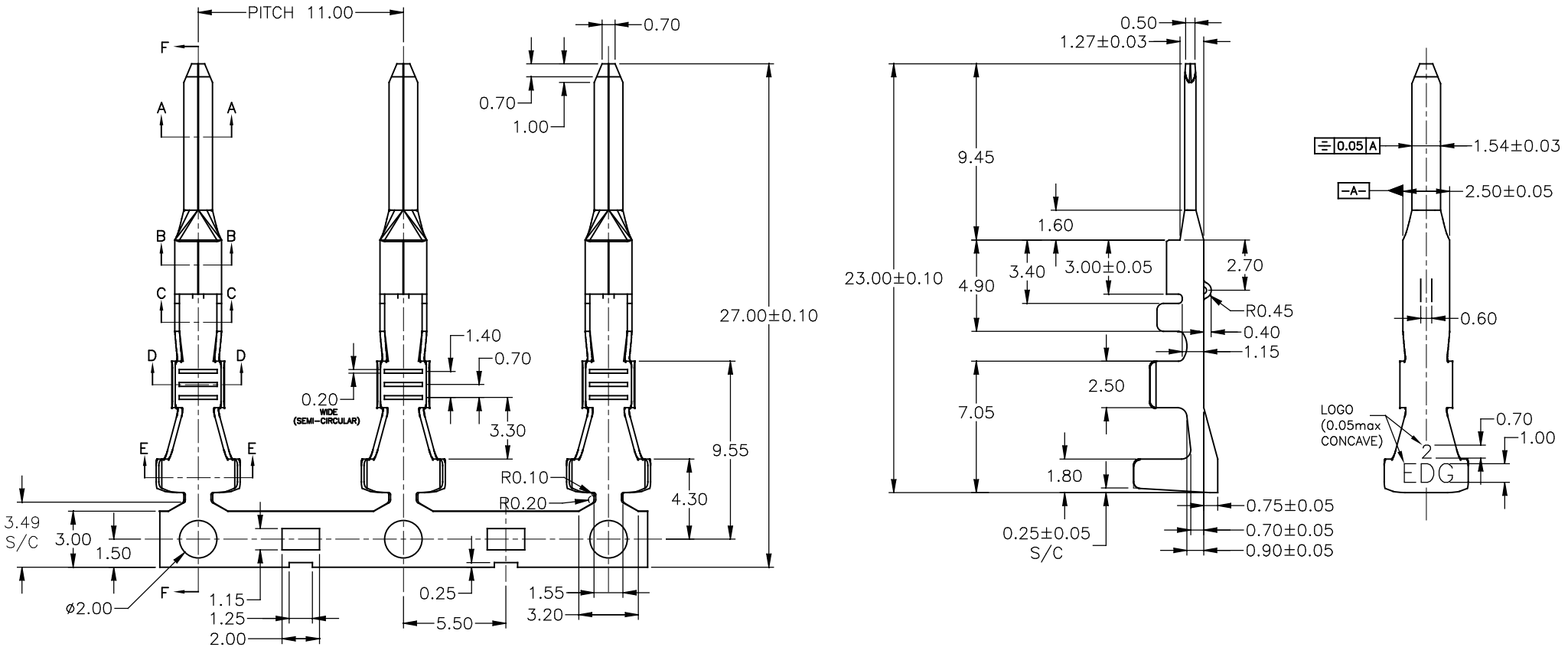

570-292-751	570-290-751	4.4±0.20	3.3±0.20	4.5±0.20	3.3±0.20	R1.60±0.05	R0.85±0.05	Brass C2680 H	AWG #14	ø3.10 max	4,000
570-293-731	570-291-731	4.4±0.20	2.8±0.20	4.5±0.20	2.8±0.20	R1.60±0.05	R0.75±0.05	Phosphor bronze C5191 1/2 H	AWG #20-16	ø3.10 max	4,000
570-292-731	570-290-731	4.4±0.20	2.8±0.20	4.5±0.20	2.8±0.20	R1.60±0.05	R0.75±0.05	Brass C2680 H	AWG #20-16	ø3.10 max	4,000
570-292-711	570-290-711	4.4±0.20	2.2±0.20	4.5±0.20	2.2±0.20	R1.40±0.05	R0.55±0.05	Brass C2680 H	AWG #22-20	ø2.70 max	4,000
UN-PLATED PART NO.	PLATED PART NO.	A1	A2	B1	B2	C1	C2	MATERIALS	AWG #	INS. DIA.	PCS/REEL

NOTES:

1. MATERIAL: SEE TABLE, 0.25mm THICK.
2. PLATING: 100-200 MICROINCHES OF BRIGHT TIN PLATING ALL OVER NICKEL 50-150 MICROINCHES UNDERPLATING.
3. SALT SPRAY TEST MUST BE NO CORROSION AFTER 24H.
4. PART SHALL BE FREE OF BURRS NOT EXCEEDING 0.02mm NO CRACKS ALLOW ON ANY SURFACES.

570 SERIES MALE CONTACT



EDAC INC
TORONTO, ONTARIO
CANADA

YOUR CONNECTION TO QUALITY & SERVICE

THESE DRAWINGS AND SPECIFICATIONS
ARE THE PROPERTY OF EDAC INC. AND
SHALL NOT BE REPRODUCED, OR COPIED
OR USED AS THE BASIS FOR THE
MANUFACTURE OR SALE OF APPARATUS
WITHOUT WRITTEN PERMISSION.

ACAD REFERENCE NO. 570-29Y-7Y1

DRAWN: Haley Hu

DATE: MAY.16/15

CHECKED:

DATE:

SCALE: (IN C.A.D. 1:1)

SHEET 1 OF 2

DRAWING NUMBER

570-29Y-7Y1

ISSUE

8

THIS IS A C.A.D. GENERATED DRAWING
DO NOT MAKE MANUAL REVISIONS TO MASTER.



* UNLESS OTHERWISE SPECIFIED TOLERANCES

ON DECIMAL IS:

UNIT: MM

DIM	TOL	DIM	TOL
X.	±0.15	X°	±2.0°
X.X	±0.10	X.X°	±1.0°
X.XX	±0.05	X.XX°	±0.5°
X.XXX	±0.03	X.XXX°	±0.3°

ISSUE NUMBER

ORIGINAL

SEE SHEET 1
Peter Deng JUN.26/19

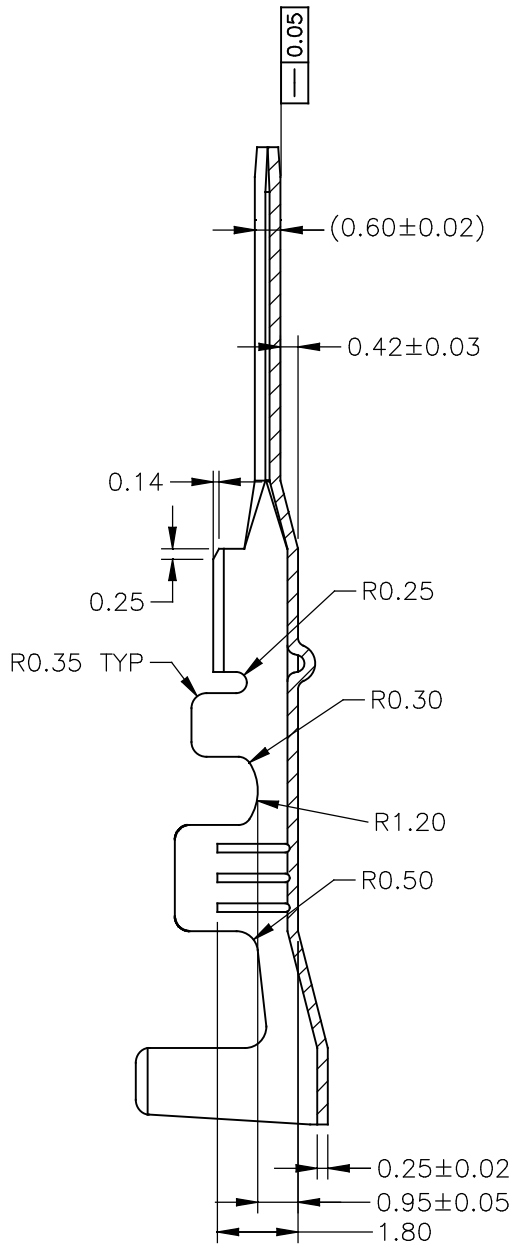

SECTION F-F
SCALE 1:1

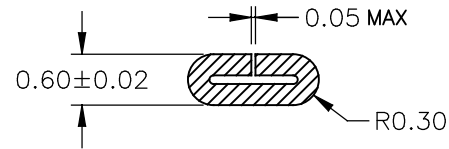

SECTION A-A
SCALE 2:1

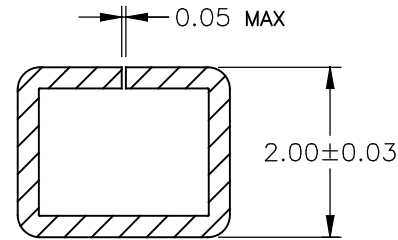

SECTION B-B
SCALE 2:1

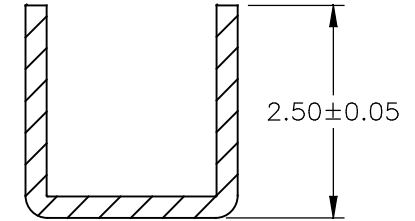

SECTION C-C
SCALE 2:1

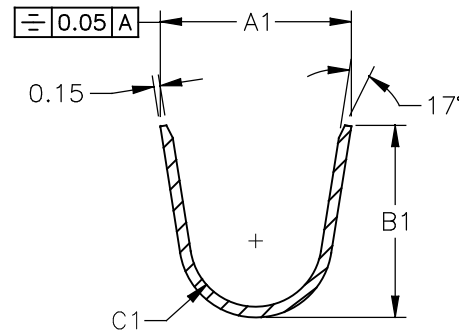

SECTION E-E
SCALE 1:1

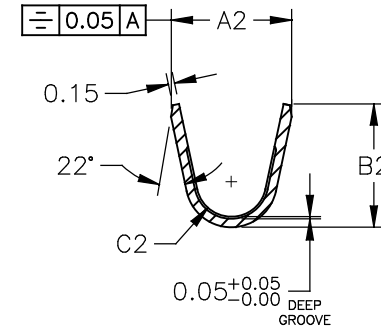

SECTION D-D
SCALE 1:1

570 SERIES MALE CONTACT

ACAD REFERENCE NO. 570-29Y-7Y1

DRAWN: Haley Hu

DATE: MAY.16/15

CHECKED:

DATE:

SCALE: (IN C.A.D. 1:1)

SHEET 2 OF 2

DRAWING NUMBER

570-29Y-7Y1

ISSUE

8



EDAC INC
TORONTO, ONTARIO
CANADA

YOUR CONNECTION TO QUALITY & SERVICE

THESE DRAWINGS AND SPECIFICATIONS
ARE THE PROPERTY OF EDAC INC. AND
SHALL NOT BE REPRODUCED, OR COPIED
OR USED AS THE BASIS FOR THE
MANUFACTURE OR SALE OF APPARATUS
WITHOUT WRITTEN PERMISSION.