**STLINK-V3MODS and STLINK-V3MINI debugger/programmer
tiny probes for STM32 microcontrollers**

Introduction

STLINK-V3MODS and STLINK-V3MINI are stand-alone debugging and programming tiny probes for STM32 microcontrollers. These products are designed in a very low form factor and both offer high performance without any compromise to functions. They support the JTAG/SWD interfaces for communication with any STM32 microcontroller located on an application board.

They provide a Virtual COM port interface allowing the host PC to communicate with the target microcontroller through one UART. The STLINK-V3MODS also provides bridge interfaces to several communication protocols allowing for instance the programming of the target through the bootloader.

The STLINK-V3MODS and STLINK-V3MINI are both proposed for different uses. The STLINK-V3MODS may be directly soldered on a host PCB including an STM32 application-based with its 2 x 16-pin castellated vias connection, while the STLINK-V3MINI offers STDC14 connectivity with an included STDC14 to STDC14 flat cable.

Figure 1. STLINK-V3MODS product top view

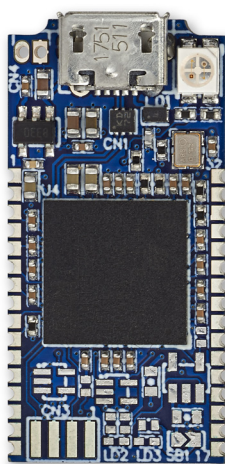
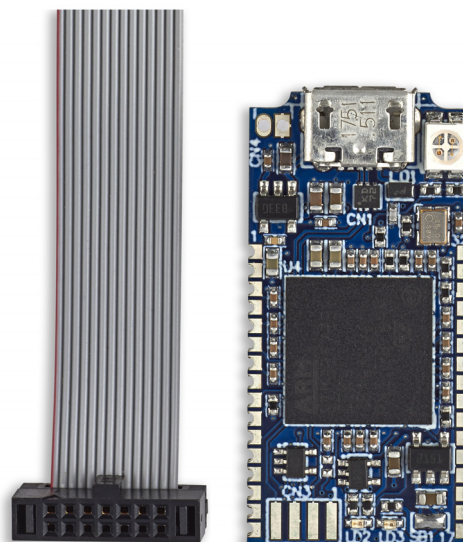

Figure 2. STLINK-V3MINI product top view



Pictures are not contractual.

Contents

- 1 Features 6**
- 2 Ordering information 7**
- 3 Development environment 8**
 - 3.1 System requirements 8
 - 3.2 Development toolchains 8
 - 3.3 Firmware upgrade 8
- 4 Quick start 9**
- 5 STLINK-V3MODS and STLINK-V3MINI functional description 10**
 - 5.1 STLINK-V3MODS and STLINK-V3MINI overview 10
 - 5.2 STLINK-V3MODS and STLINK-V3MINI frequency selection 10
 - 5.3 High-performance modules 10
 - 5.4 Hardware layout 12
 - 5.5 STLINK-V3MODS and STLINK-V3MINI functions 15
 - 5.5.1 SWD with SWV 15
 - 5.5.2 JTAG 15
 - 5.5.3 Virtual COM port (VCP) 15
 - 5.5.4 Mass storage interface 15
 - 5.5.5 Bridge functions (STLINK-V3MODS only) 15
 - 5.5.6 LEDs 16
- 6 Board connectors 17**
 - 6.1 Connectors 17
 - 6.1.1 USB Micro-B 17
 - 6.1.2 32-pin edge connector for STLINK-V3MODS (STM32 JTAG/SWD, VCP and bridges) 17
 - 6.1.3 STDC14 for STLINK-V3MINI (STM32 JTAG/SWD and VCP) 19
- 7 Product information 20**
 - 7.1 Product marking 20
 - 7.2 Product history 20

7.2.1	Product identification LKV3MODS\$AT1	20
7.2.2	Product identification LKV3MODS\$AT2	20
7.2.3	Product identification LKV3MINI\$AT1	20
7.2.4	Product identification LKV3MINI\$AT2	21
7.3	Board revision history	21
7.3.1	Board MB1467 revision B-01	21
7.3.2	Board MB1467 revision B-02	21
Appendix A	STLINK-V3MODS recommended land pattern	22
Appendix B	STLINK-V3MODS board dimensions	23
Appendix C	STLINK-V3MODS reference design for voltage adapter	24
Appendix D	Federal Communications Commission (FCC) and Innovation, Science and Economic Development Canada (ISED) Compliance Statements	25
D.1	FCC Compliance Statement	25
D.2	ISED Compliance Statement	25
Revision history	27

List of tables

Table 1.	Ordering information	7
Table 2.	I/O type definition	17
Table 3.	32-pin edge connector for STLINK-V3MODS.	17
Table 4.	CN5 STDC14 connector pinout	19
Table 5.	Document revision history	27

List of figures

Figure 1.	STLINK-V3MODS product top view	1
Figure 2.	STLINK-V3MINI product top view	1
Figure 3.	STLINK-V3MINI connections	11
Figure 4.	STLINK-V3MODS connections.	11
Figure 5.	Hardware board STLINK-V3MODS	12
Figure 6.	Hardware board STLINK-V3MINI	13
Figure 7.	MB1467 top layout	13
Figure 8.	MB1467 bottom layout	14
Figure 9.	MB1467 mechanical drawing (in millimeters)	14
Figure 10.	CN5 STDC14 connector (Top view)	19
Figure 11.	STLINK-V3MODS recommended land pattern.	22
Figure 12.	STLINK-V3MODS mechanical dimensions (in millimeters)	23

1 Features

Common features

- Tiny 15 mm x 30 mm standalone debugging and programming probes for STM32 microcontrollers
- Self-powered through a USB Micro-B connector
- USB 2.0 high-speed interface
- Probe firmware update through USB
- Optional drag-and-drop Flash memory programming of binary files
- Two-color LEDs: communication, power
- JTAG communication support up to 21 MHz
- SWD (Serial Wire Debug) and SWV (Serial Wire Viewer) communication support up to 24 MHz
- Virtual COM port (VCP) up to 16 Mbps
- 3.0 to 3.6 V application voltage support and 5 V tolerant inputs

STLINK-V3MODS features

- Direct-to-PCB implementation by 2 x 16-pin 1.27mm edge castellated vias with all signals available in a minimum PCB required surface
- Multi-path bridge USB to SPI/UART/I²C/CAN/GPIOs

STLINK-V3MINI features

- 1.27 mm pitch STDC14 debug connector with STDC14 to STDC14 flat cable
- STDC14 signals protection

Note: The *STLINK-V3MINI* tiny probe does not provide any power supply to the target application.

2 Ordering information

To order the STLINK-V3MODS or STLINK-V3MINI tiny probe, refer to [Table 1](#).

Table 1. Ordering information

Order code	Content and references	Description	Differentiating feature
STLINK-V3MODS	– MB1467 ⁽¹⁾	STLINK-V3 in-circuit debugger and programmer for STM32 microcontrollers	– 2 x 16-pin castellated vias
STLINK-V3MINI	– MB1467 ⁽¹⁾ – FFC ⁽²⁾		– STDC14 connector – Flexible flat cable

1. Tiny probe board
2. Flexible flat cable

3 Development environment

The STLINK-V3MODS and STLINK-V3MINI tiny probes run with an STM32 32-bit microcontroller based on the Arm^{®(a)} Cortex[®]-M core.



3.1 System requirements

- Multi-OS support: Windows[®] 10, Linux[®] 64-bit, or macOS^{®(b)(c)(d)}
- USB Type-A or USB Type-C[®] to Micro-B cable

3.2 Development toolchains

- IAR Systems[®] - IAR Embedded Workbench^{®(e)}
- Keil[®] - MDK-ARM^(e)
- STMicroelectronics - STM32CubeIDE

3.3 Firmware upgrade

The STLINK-V3MODS and STLINK-V3MINI tiny probes embed firmware which needs to be frequently updated from the www.st.com website to benefit from new functionality or corrections. Refer to the technical note *Overview of ST-LINK derivatives* (TN1235) for details.

-
- a. Arm is a registered trademark of Arm Limited (or its subsidiaries) in the US and or elsewhere.
 - b. macOS[®] is a trademark of Apple Inc. registered in the U.S. and other countries.
 - c. Linux[®] is a registered trademark of Linus Torvalds.
 - d. All other trademarks are the property of their respective owners.
 - e. On Windows[®] only.

4 Quick start

This section describes how to start development quickly using the STLINK-V3MODS and STLINK-V3MINI.

Before installing and using these products, accept the Evaluation Product License Agreement from the www.st.com/epla web page.

The STLINK-V3MODS and STLINK-V3MINI are stand-alone debugging and programming probes for STM32 microcontrollers.

- They support protocols JTAG and SWD to communicate with any STM32 microcontroller.
- They provide a Virtual COM port interface allowing the host PC to communicate with the target microcontroller through one UART
- The STLINK-V3MODS provides bridge interfaces to several communication protocols allowing for instance the programming of the target through the bootloader.

To start using STLINK-V3MINI, follow the steps below:

1. Check that the STDC14 to STDC14 flat cable is present inside the box.
2. Install/update the IDE/STM32CubeProgrammer to support the STLINK-V3MINI (drivers).
3. Connect the flat cable between the STLINK-V3MINI and the application.
4. Connect a USB Type-A to Micro-B cable between the STLINK-V3MINI and the PC.
5. Check that the PWR LED is green and the COM LED is red.
6. Open the development toolchain or STM32CubeProgrammer software utility. For more details, refer to the www.st.com/stlink-v3mini website.

Using STLINK-V3MODS requires to be firstly soldered onto the destination application including the targeted STM32 microcontroller. Some recommendations are given here:

1. Reserve in the design the necessary PCB area under the STLINK-V3MODS by using the recommended PCB land pattern.
2. Apply the recommended reflow soldering profile, from *Soldering recommendations and package information for Lead-free ECOPACK microcontrollers (AN2639)*, and verify that contacts between host board and module meet the IPC Specification (see IPC-A-610-F Acceptability of Electronic Assemblies).
3. Install/update the IDE/STM32CubeProgrammer to support the STLINK-V3MODS (drivers).
4. Power supply the application board.
5. Connect a USB Type-A to Micro-B cable between the STLINK-V3MODS and the PC.
6. Check that the PWR LED is green and the COM LED is red.
7. Open the development toolchain or STM32CubeProgrammer software utility. For more details, refer to the www.st.com/stlink-v3mods website.

5 STLINK-V3MODS and STLINK-V3MINI functional description

5.1 STLINK-V3MODS and STLINK-V3MINI overview

STLINK-V3MODS and STLINK-V3MINI are stand-alone debugging and programming tiny probes for STM32 microcontrollers. These products support many functions and protocols for debugging, programming, or communicating with one or several targets.

These modules are fully powered by the PC. If the COM LED blinks red, refer to the technical note *Overview of ST-LINK derivatives* (TN1235) for details.

5.2 STLINK-V3MODS and STLINK-V3MINI frequency selection

The STLINK-V3MODS and STLINK-V3MINI run internally at three different frequencies:

- high-performance frequency
- standard frequency, compromising between performance and consumption
- low-consumption frequency

By default, the STLINK-V3MODS and STLINK-V3MINI start in high-performance frequency. It is the responsibility of the toolchain provider to propose or not the frequency selection at the user level.

5.3 High-performance modules

The STLINK-V3MODS and STLINK-V3MINI support high-performance configuration for STM32 microcontrollers. The working voltage range is from 3.0 to 3.6 V.

The protocols and functions supported are:

- SWD (up to 24 MHz) with SWO (up to 16 MHz)
- JTAG (up to 21 MHz)
- VCP (from 732 bps to 16 Mbps)

Figure 3. STLINK-V3MINI connections

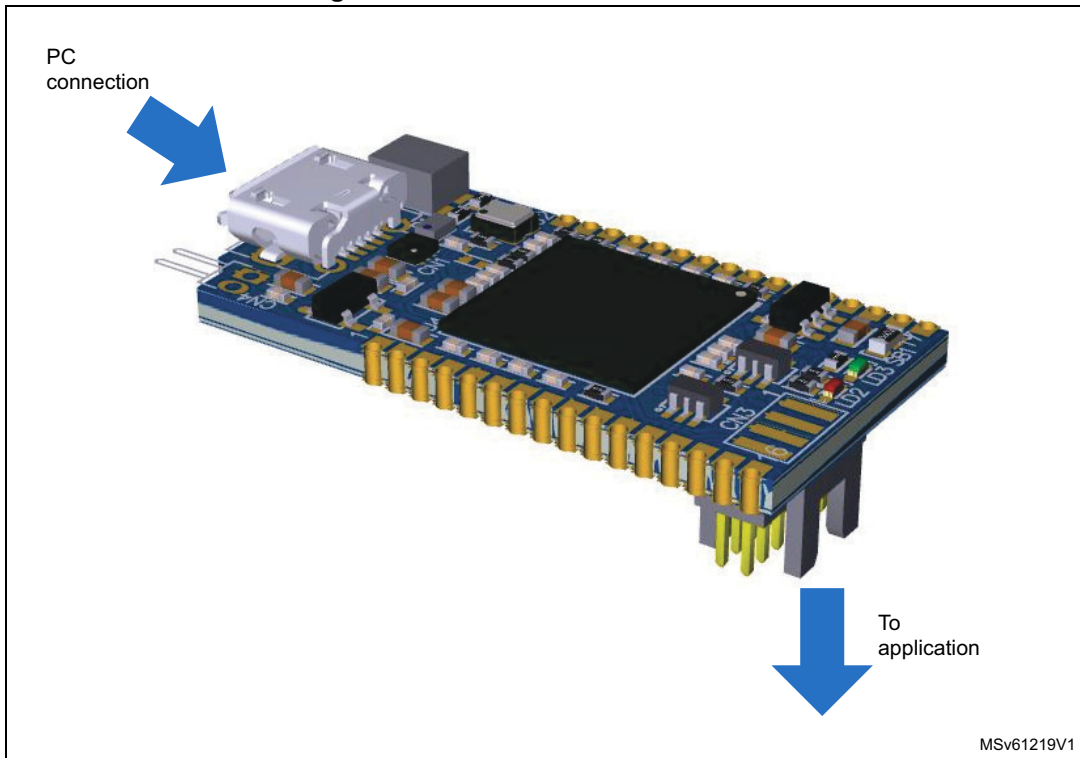
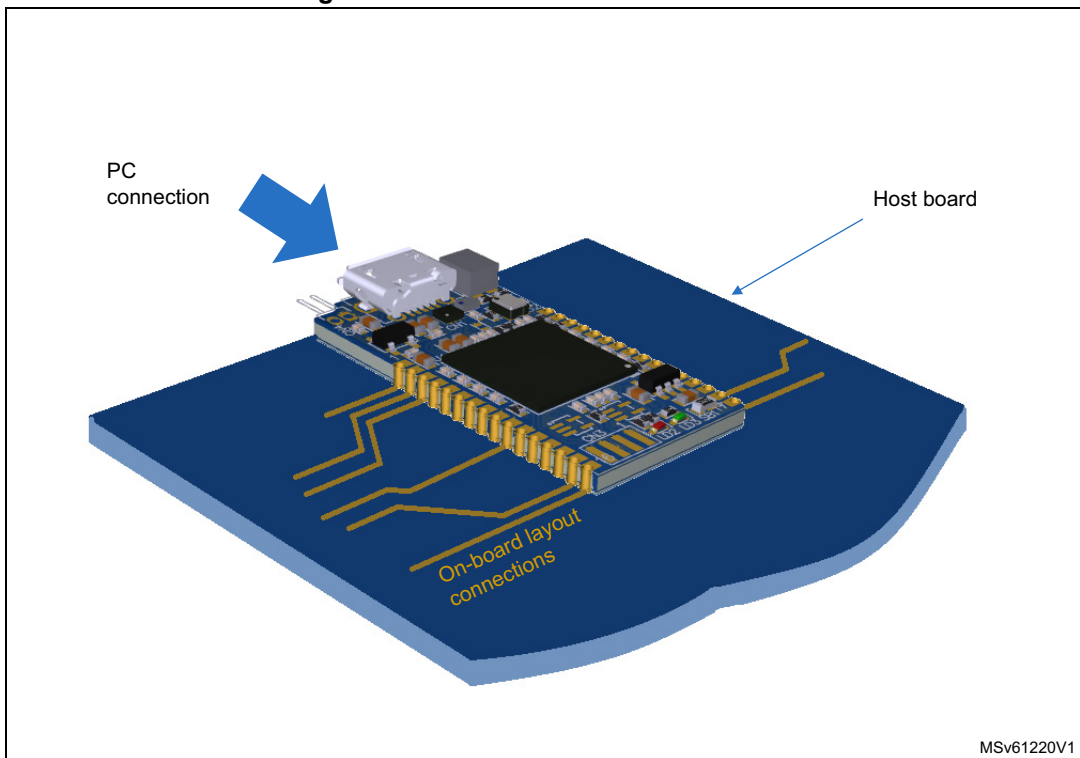

Figure 4. STLINK-V3MODS connections



For the STLINK-V3MODS, the connections are done with the host board by tracks.

5.4 Hardware layout

The STLINK-V3MODS and STLINK-V3MINI products are designed around the STM32F723 microcontroller (176-pin in UFBGA package). [Figure 5](#) shows the STLINK-V3MODS and [Figure 6](#) the STLINK-V3MINI. [Figure 7](#) and [Figure 8](#) show MB1467 top and bottom layouts which is the common board reference for STLINK-V3MODS and STLINK-V3MINI.

Figure 5. Hardware board STLINK-V3MODS

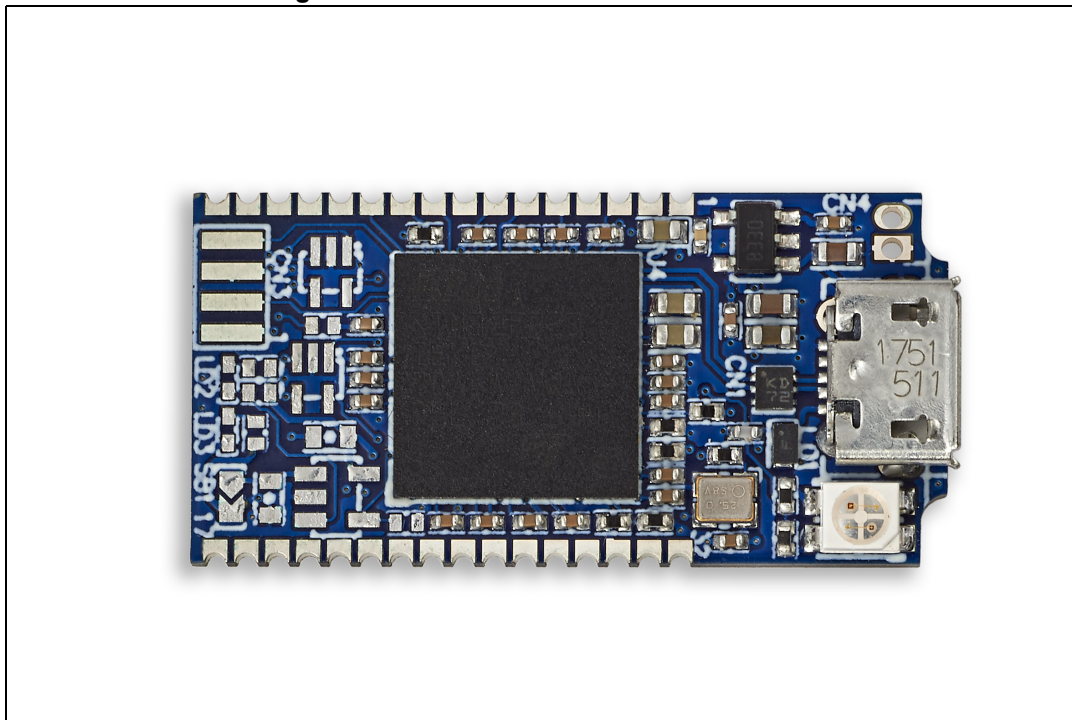

Figure 6. Hardware board STLINK-V3MINI

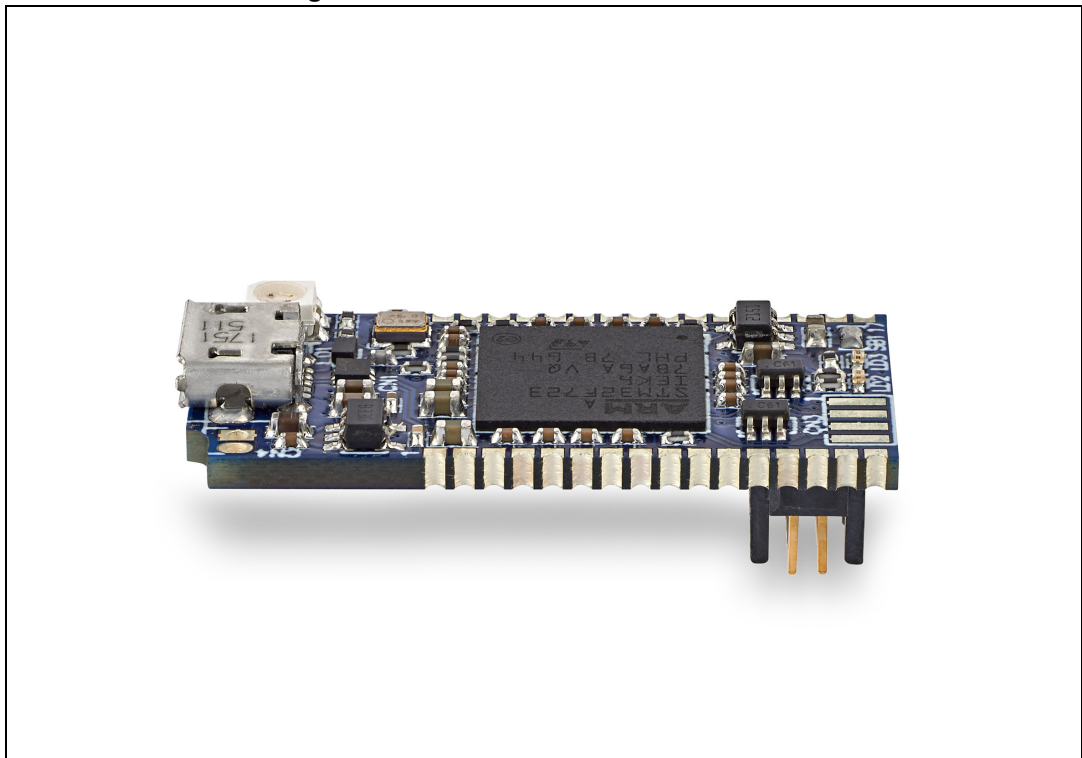

Figure 7. MB1467 top layout

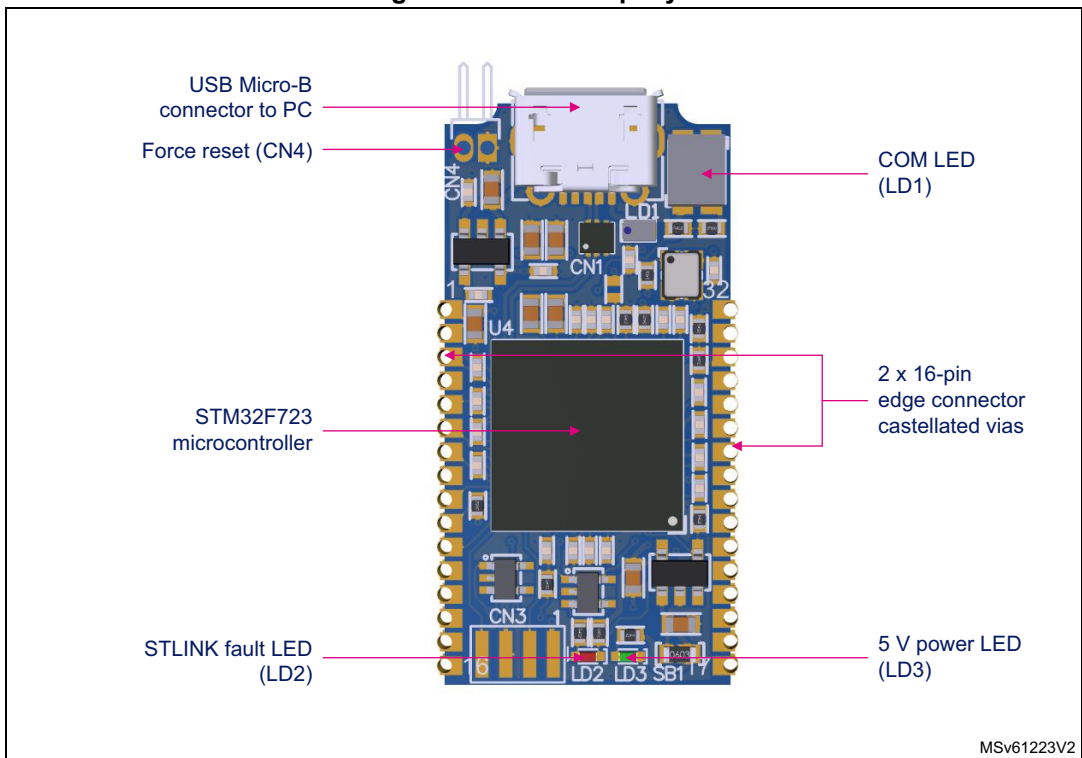

Figure 8. MB1467 bottom layout

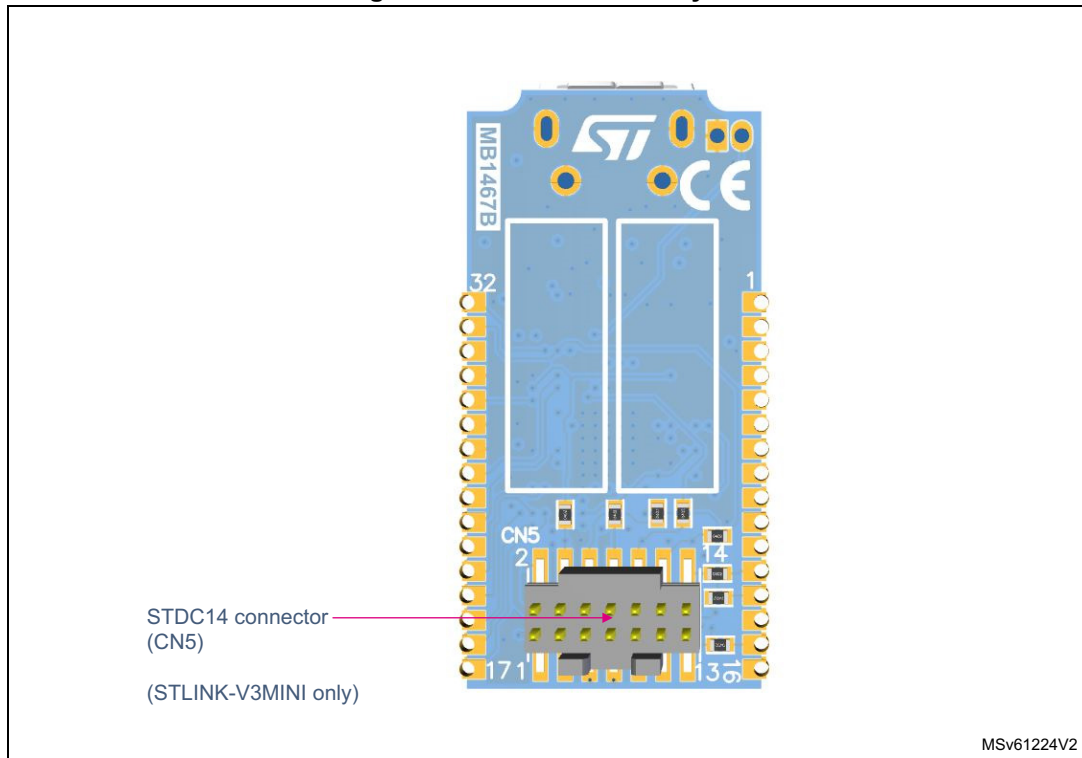
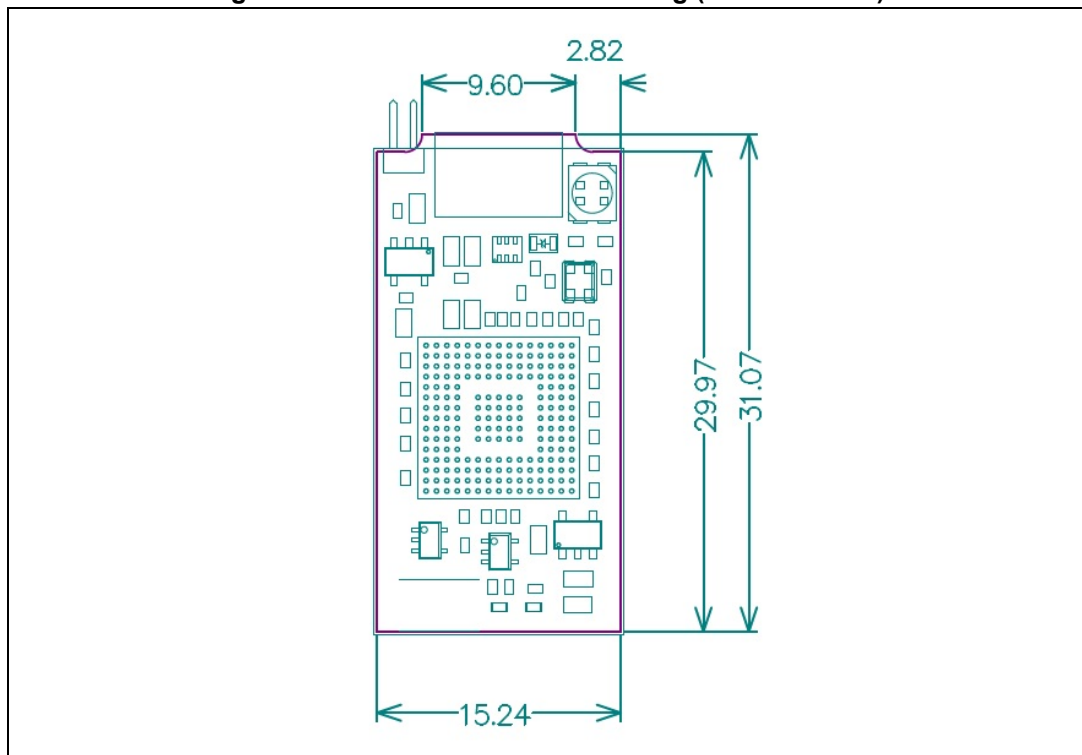

Figure 9. MB1467 mechanical drawing (in millimeters)



5.5 STLINK-V3MODS and STLINK-V3MINI functions

All functions are designed for high performance: all signals are 3.3 V compatible. The following description concerns STLINK-V3MODS and STLINK-V3MINI except for some mentioned sections and indicates where to find the functions on the boards and connectors.

5.5.1 SWD with SWV

SWD protocol is a Debug/Program protocol used for STM32 microcontrollers with SWV as a trace. The signals are 3.3 V compatible and may perform up to 24 MHz. This function is available on CN2 (STLINK-V3MODS) and CN5 (STLINK-V3MINI).

5.5.2 JTAG

JTAG protocol is a Debug/Program protocol used for STM32 microcontrollers. The signals are 3.3 V compatible and may perform up to 21 MHz. This function is available on CN2 (STLINK-V3MODS) and CN5 (STLINK-V3MINI).

5.5.3 Virtual COM port (VCP)

The serial interface VCP is directly available as a Virtual COM port of the PC, connected to STLINK-V3MODS and STLINK-V3MINI USB connector CN5. This function may be used for STM32 microcontrollers. The signals are 3.3 V compatible and may perform from 732 bps to 16 Mbps. This function is available on CN2 (STLINK-V3MODS) and CN5 (STLINK-V3MINI).

A second Virtual COM port may be activated on STLINK-V3MODS, as detailed later in [Section 5.5.5](#) (Bridge UART).

For details regarding baud rates, refer to *section 14.2.* of the user manual *STLINK-V3SET debugger/programmer for STM8 and STM32* (UM2448).

5.5.4 Mass storage interface

The STLINK-V3MODS and STLINK-V3MINI tiny probes implement a virtual mass storage interface allowing the programming of an STM32 target Flash memory with drag-and-drop action of a binary file from a file explorer. This ability requires the STLINK-V3MODS or STLINK-V3MINI tiny probe to identify the connected target before enumerating it on the USB host. As a consequence, this functionality is available only if the target is connected to the STLINK-V3MODS or STLINK-V3MINI tiny probe when it powers up.

The mass storage interface may be disabled or enabled again by reprogramming the ST-LINK firmware. This can be performed with the *STLinkUpgrade* application. Activate the *<change type>* checkbox then select the firmware with or without mass storage and launch the update. The action is reversible.

5.5.5 Bridge functions (STLINK-V3MODS only)

The STLINK-V3MODS tiny probe provides a proprietary USB interface allowing the communication with an STM32 target with several protocols: SPI, I²C, CAN, UART and GPIOs. This interface may be used to communicate with the target bootloader, but may also be used for customized needs through its public software interface. All bridge signals are accessible on CN2.

Bridge SPI

SPI signals are available on CN2 pins 7, 14, 23, and 25.

Bridge I²C

I²C signals are available on CN2 pins 16 and 17. It is necessary to add externally 680 Ω pull-up resistors on the host application board.

Bridge CAN

CAN logic signals (Rx/Tx) are available on CN2 pins 9 and 10, they may be used as input for an external CAN transceiver.

Bridge UART

UART signals with hardware flow control (CTS/RTS) are available on MB1467 CN2 pins 1, 2, 3, and 11. They need dedicated firmware to be programmed on the main module before being used. Without this firmware, the Virtual COM port function must be used instead (no hardware flow control).

Bridge GPIOs

Four GPIO signals are available on CN2 pins 18 and 21. Basic management is provided by the public ST bridge software interface.

5.5.6 LEDs

Power LED: Red light indicates that 5 V is enabled.

COM LED: Refer to the technical note *Overview of ST-LINK derivatives* (TN1235) for details.

Fault LED: Indicates USB overcurrent request.

6 Board connectors

6.1 Connectors

Per convention, please refer to [Table 2](#) for I/O Type definition:

Table 2. I/O type definition

Type	Definition
S	Supply pin
I	Input only pin
O	Output only pin
I/O	Input/Output pin

6.1.1 USB Micro-B

The CN5 USB connector is used to connect the embedded STLINK-V3MODS or STLINK-V3MINI to the PC.

6.1.2 32-pin edge connector for STLINK-V3MODS (STM32 JTAG/SWD, VCP and bridges)

Table 3. 32-pin edge connector for STLINK-V3MODS

Side	Pin #	Pin description	Type
LEFT	1	Bridge UART RX ⁽¹⁾	I
	2	Bridge UART CTS	I
	3	Bridge UART RTS	O
	4	T_JTMS/T_SWDIO	I/O
	5	GNDDetect	O
	6	T_JTDO/T_SWO ⁽²⁾	I
	7	Bridge SPI CLK	I/O
	8	GND	S
	9	Bridge CAN RX ⁽¹⁾	I
	10	Bridge CAN TX ⁽³⁾	O
	11	Bridge UART TX ⁽³⁾	O
	12	T_VCP_TX	I
	13	T_JCLK/T_SWCLK	O
	14	Bridge SPI NSS	I/O
	15	T_VCP_RX	O
	16	Bridge I2C SCL	O

Table 3. 32-pin edge connector for STLINK-V3MODS (continued)

Side	Pin #	Pin description	Type
RIGHT	17	Bridge I2C SDA	I/O
	18	Bridge GPIO0	I/O
	19	Bridge GPIO1	I/O
	20	Bridge GPIO2	I/O
	21	Bridge GPIO3	I/O
	22	5 V ⁽⁴⁾	O
	23	Bridge SPI MISO	I/O
	24	GND	S
	25	Bridge SPI MOSI	I/O
	26	GND	S
	27	GND	S
	28	T_JTDI/NC ⁽⁵⁾	O
	29	GND	S
	30	T_VCC ⁽⁶⁾	I
	31	T_NRST	O
	32	T_SW_DIR	O

1. RX signals are inputs for STLINK-V3MODS, outputs for the target.
2. SWO is optional, required only for Serial Wire Viewer (SWV) trace.
3. TX signals are outputs for STLINK-V3MODS, inputs for the target.
4. Can drive 5 V +/- 5% with a 200 mA maximum current.
5. NC means not required for SWD connection.
6. Input for STLINK-V3MODS.

5 V source output capability

Pin 22 of the right edge pin connector can drive a 5 V target with a maximum output current of 200 mA. The 5 V is guaranteed to be in the +/- 5% range if the driven current does not exceed 200 mA. Please notice that exceeding this maximum output current over 200 mA may damage the device or cause communication issues with the host PC (A PC standard USB connector cannot provide more than 500 mA by the USB port and STLINK-V3MODS can request dynamic current surges during target devices programming).

6.1.3 STDC14 for STLINK-V3MINI (STM32 JTAG/SWD and VCP)

The CN5 STDC14 connector allows the connection to an STM32 target using the JTAG or SWD protocol, respecting (from pin 3 to pin 12) the ARM10 pinout (Arm Cortex Debug connector). But it also advantageously provides two UART signals for the Virtual COM port. The related pinout for the STDC14 connector is listed in [Table 4](#).

Figure 10. CN5 STDC14 connector (Top view)

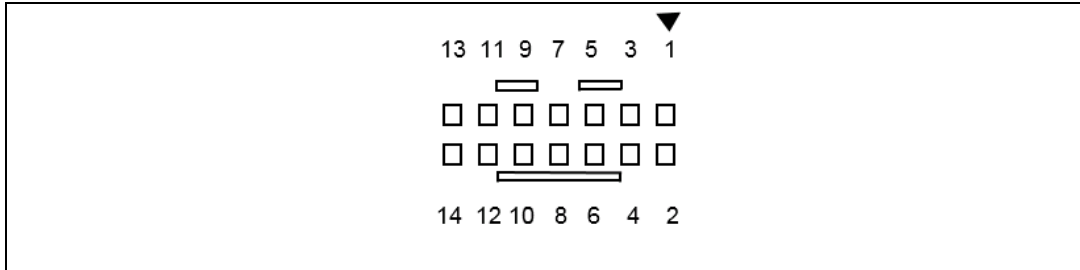

Table 4. CN5 STDC14 connector pinout

STDC14 Pin #	ARM10 Pin #	Pin description	Type
1	-	Reserved ⁽¹⁾	-
2	-	Reserved ⁽¹⁾	-
3	1	T_VCC ⁽²⁾	I
4	2	T_JTMS/T_SWDIO	I/O
5	3	GND	S
6	4	T_JCLK/T_SWCLK	O
7	5	GND	S
8	6	T_JTDO/T_SWO ⁽³⁾	I
9	7	T_JCLK	O
10	8	T_JTDI/NC ⁽⁴⁾	O
11	9	GNDDetect	O
12	10	T_NRST	O
13	-	T_VCP_RX	O
14	-	T_VCP_TX	I

1. Do not connect on target.
2. T_VCC is an input for STLINK-V3MINI.
3. SWO is optional, required only for Serial Wire Viewer (SWV) trace.
4. NC means not required for SWD connection.

7 Product information

7.1 Product marking

The stickers located on the top or bottom side of the PCB provide product information:

- Product order code and product identification for the first sticker
- Board reference with revision, and serial number for the second sticker

On the first sticker, the first line provides the product order code, and the second line the product identification.

On the second sticker, the first line has the following format: "MBxxxx-Variant-yzz", where "MBxxxx" is the board reference, "Variant" (optional) identifies the mounting variant when several exist, "y" is the PCB revision and "zz" is the assembly revision, for example B01. The second line shows the board serial number used for traceability.

Evaluation tools marked as "ES" or "E" are not yet qualified and therefore not ready to be used as reference design or in production. Any consequences deriving from such usage will not be at ST charge. In no event, ST will be liable for any customer usage of these engineering sample tools as reference designs or in production.

"E" or "ES" marking examples of location:

- On the targeted STM32 that is soldered on the board (For an illustration of STM32 marking, refer to the STM32 datasheet "Package information" paragraph at the www.st.com website).
- Next to the evaluation tool ordering part number that is stuck or silk-screen printed on the board.

7.2 Product history

7.2.1 Product identification LKV3MODS\$AT1

This product identification is based on the MB1467 revision B-01.

Product limitation

No limitation identified for this product identification.

7.2.2 Product identification LKV3MODS\$AT2

This product identification is based on the MB1467 revision B-02, where R3 is fitted on the board.

Product limitation

No limitation identified for this product identification.

7.2.3 Product identification LKV3MINI\$AT1

This product identification is based on the MB1467 revision B-01.

Product limitation

No limitation identified for this product identification.

7.2.4 Product identification LKV3MINI\$AT2

This product identification is based on the MB1467 revision B-02, where R3 is fitted on the board.

Product limitation

No limitation identified for this product identification.

7.3 Board revision history**7.3.1 Board MB1467 revision B-01**

The revision B-01 of the MB1467 board is the first official version.

Board limitation

No limitation identified for this board revision.

7.3.2 Board MB1467 revision B-02

The revision B-02 of the MB1467 board is the version where R3 is fitted on the board.

Board limitation

No limitation identified for this board revision.

Appendix A STLINK-V3MODS recommended land pattern

Figure 11. STLINK-V3MODS recommended land pattern

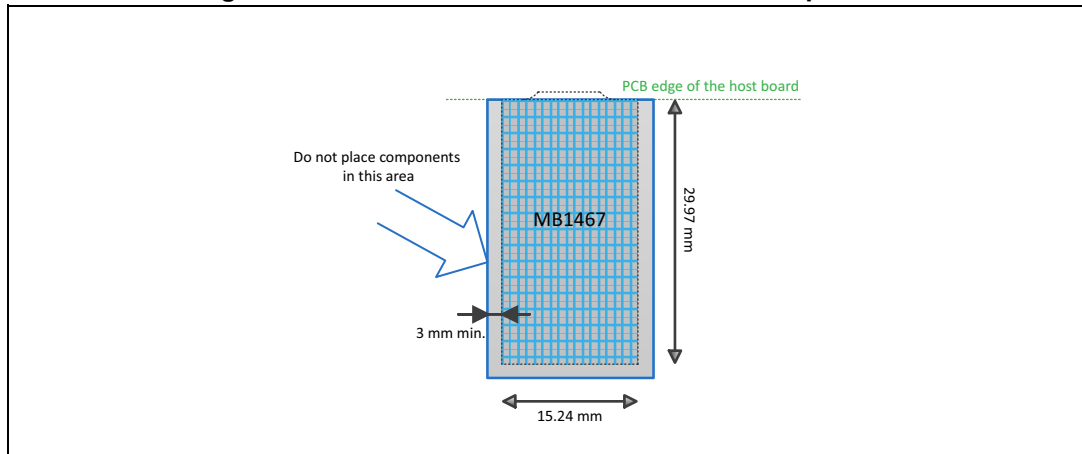

Appendix B STLINK-V3MODS board dimensions

Figure 12. STLINK-V3MODS mechanical dimensions (in millimeters)

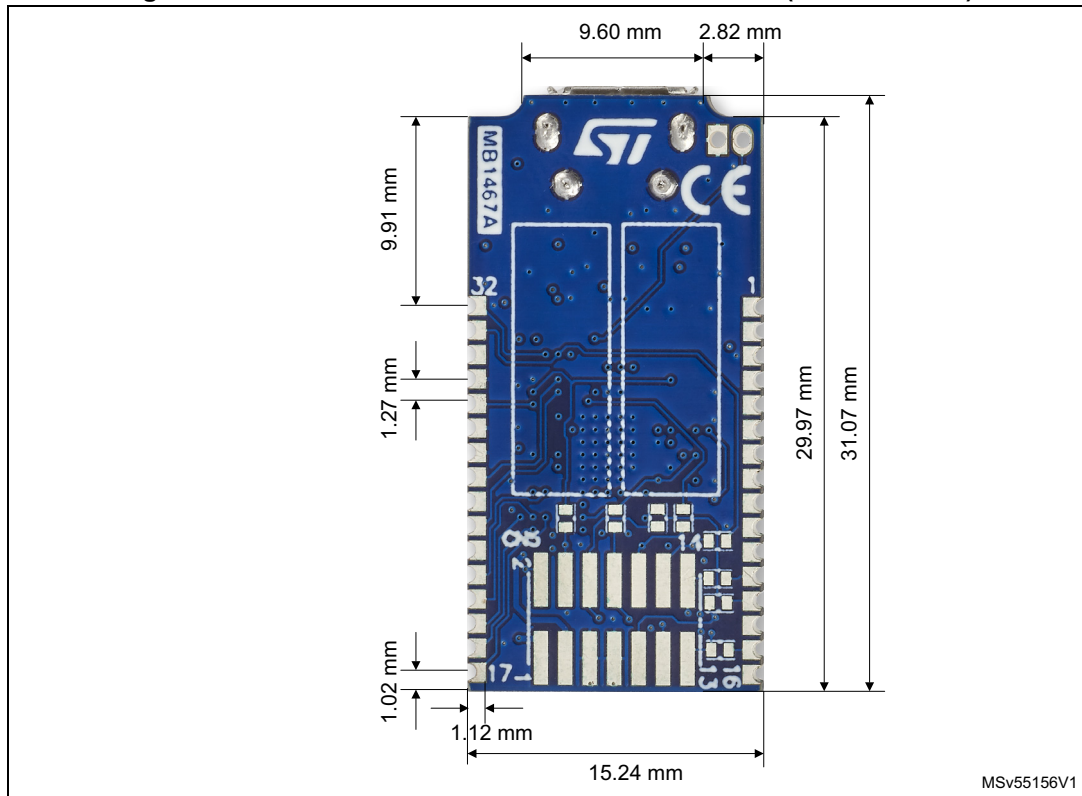

Appendix C **STLINK-V3MODS reference design for voltage adapter**

A document describing how to connect a voltage adapter to the STLINK-V3MODS is available on the www.st.com/stlink-v3mods website under the CAD resources tab. This document is given as a guidance and reference design helping customers how to realize a 1.65 to 3.60 V voltage adapter to the STLINK-V3MODS compact in-circuit debugger and programmer for STM32.

Appendix D Federal Communications Commission (FCC) and Innovation, Science and Economic Development Canada (ISED) Compliance Statements

D.1 FCC Compliance Statement

Part 15.19

This device complies with Part 15 of the FCC Rules. Operation is subject to the following two conditions: (1) this device may not cause harmful interference, and (2) this device must accept any interference received, including interference that may cause undesired operation.

Part 15.21

Any changes or modifications to this equipment not expressly approved by STMicroelectronics may cause harmful interference and void the user's authority to operate this equipment.

Part 15.105

This equipment has been tested and found to comply with the limits for a Class A digital device, pursuant to part 15 of the FCC Rules. These limits are designed to provide reasonable protection against harmful interference when the equipment is operated in a commercial environment. This equipment generates, uses, and can radiate radio frequency energy and, if not installed and used in accordance with the instruction manual, may cause harmful interference to radio communications. Operation of this equipment in a residential area is likely to cause harmful interference in which case the user will be required to correct the interference at his own expense.

Responsible party (in the USA)

Terry Blanchard
Americas Region Legal | Group Vice President and Regional Legal Counsel, The Americas
STMicroelectronics, Inc.
750 Canyon Drive | Suite 300 | Coppell, Texas 75019
USA
Tel: +1 972-466-7845

D.2 ISED Compliance Statement

This device complies with FCC and ISED Canada RF radiation exposure limits set forth for general population for mobile application (uncontrolled exposure). This device must not be collocated or operating in conjunction with any other antenna or transmitter.

Compliance Statement

Notice: This device complies with ISED Canada licence-exempt RSS standard(s). Operation is subject to the following two conditions: (1) this device may not cause

interference, and (2) this device must accept any interference, including interference that may cause undesired operation of the device.

ISED Canada ICES-003 Compliance Label: CAN ICES-3 (A)/NMB-3(A).

Déclaration de conformité

Avis: Le présent appareil est conforme aux CNR d'ISDE Canada applicables aux appareils radio exempts de licence. L'exploitation est autorisée aux deux conditions suivantes : (1) l'appareil ne doit pas produire de brouillage, et (2) l'utilisateur de l'appareil doit accepter tout brouillage radioélectrique subi, même si le brouillage est susceptible d'en compromettre le fonctionnement

Étiquette de conformité à la NMB-003 d'ISDE Canada: CAN ICES-3 (A)/NMB-3(A).

Revision history

Table 5. Document revision history

Date	Revision	Changes
11-Apr-2019	1	Initial release.
14-Dec-2021	2	Reshuffle of the document to align with latest standards: <ul style="list-style-type: none"> – <i>Introduction</i> to <i>Quick start</i> reordering – Former <i>Software configuration</i> subsections spread between <i>Development environment</i> and <i>STLINK-V3MODS and STLINK-V3MINI functional description</i> Added: <ul style="list-style-type: none"> – <i>5 V source output capability</i> subsection – <i>STLINK-V3MODS board dimensions</i> with new <i>Figure 12</i> – <i>STLINK-V3MODS reference design for voltage adapter</i> Updated: <ul style="list-style-type: none"> – Title, <i>Features</i>, <i>Figure 7</i>, <i>Figure 8</i>, <i>Table 3</i> and <i>Table 4</i> – <i>Virtual COM port (VCP)</i> and <i>Bridge functions (STLINK-V3MODS only)</i> – <i>Product information</i> and <i>Federal Communications Commission (FCC) and Innovation, Science and Economic Development Canada (ISED) Compliance Statements</i>

IMPORTANT NOTICE – PLEASE READ CAREFULLY

STMicroelectronics NV and its subsidiaries (“ST”) reserve the right to make changes, corrections, enhancements, modifications, and improvements to ST products and/or to this document at any time without notice. Purchasers should obtain the latest relevant information on ST products before placing orders. ST products are sold pursuant to ST’s terms and conditions of sale in place at the time of order acknowledgement.

Purchasers are solely responsible for the choice, selection, and use of ST products and ST assumes no liability for application assistance or the design of Purchasers’ products.

No license, express or implied, to any intellectual property right is granted by ST herein.

Resale of ST products with provisions different from the information set forth herein shall void any warranty granted by ST for such product.

ST and the ST logo are trademarks of ST. For additional information about ST trademarks, please refer to www.st.com/trademarks. All other product or service names are the property of their respective owners.

Information in this document supersedes and replaces information previously supplied in any prior versions of this document.

© 2021 STMicroelectronics – All rights reserved