

High-Speed CAN Transceiver with Standby Mode

Features

- Fully ISO 11898-2, ISO 11898-2: 2016 and SAE J2962-2 Compliant
- CAN FD Ready
- Communication Speed up to 5 Mbps
- Low Electromagnetic Emission (EME) and High Electromagnetic Immunity (EMI)
- Differential Receiver with Wide Common Mode Range
- ATA6562: Silent Mode
- Remote Wake-Up Capability via CAN Bus - Wake-Up on Pattern (WUP), as Specified in ISO 11898-2: 2016, 3.8 μ s Activity Filter Time
- Functional Behavior Predictable under All Supply Conditions
- Transceiver Disengages from the Bus When Not Powered Up
- RXD Recessive Clamping Detection
- High Electrostatic Discharge (ESD) Handling Capability on the Bus Pins
- Bus Pins Protected Against Transients in Automotive Environments
- Transmit Data (TXD) Dominant Time-Out Function
- Undervoltage Detection on VCC and VIO Pins
- CANH/CANL Short-Circuit and Overtemperature Protected
- Fulfills the OEM "Hardware Requirements for LIN, CAN and FlexRay Interfaces in Automotive Applications, Rev. 1.3"
- Qualified According to AEC-Q100 and AEC-Q006
- Two Ambient Temperature Grades Available:
 - ATA6562-GAQW1, ATA6563-GAQW1, ATA6562-GBQW1 and ATA6563-GBQW1 up to $T_{amb} = +125^{\circ}\text{C}$
 - ATA6562-GAQW0, ATA6563-GAQW0, ATA6562-GBQW0 and ATA6563-GBQW0 up to $T_{amb} = +150^{\circ}\text{C}$
- Packages: SOIC8, VDFN8 with Wettable Flanks (Moisture Sensitivity Level 1)

Applications

Classical CAN and CAN FD networks in Automotive, Industrial, Aerospace, Medical and Consumer applications.

General Description

The ATA6562/ATA6563 is a high-speed CAN transceiver that provides an interface between a controller area network (CAN) protocol controller and the physical two-wire CAN bus.

The transceiver is designed for high-speed (up to 5 Mbps) CAN applications in the automotive industry, providing differential transmit and receive capability to (a microcontroller with) a CAN protocol controller. It offers improved electromagnetic compatibility (EMC) and electrostatic discharge (ESD) performance, as well as features such as:

- Ideal passive behavior to the CAN bus when the supply voltage is off
- Direct interfacing to microcontrollers with supply voltages from 3V to 5V (ATA6563)

Three operating modes together with the dedicated fail-safe features make the ATA6562/ATA6563 an excellent choice for all types of high-speed CAN networks, especially in nodes requiring low-power mode with wake-up capability via the CAN bus.

Package Types

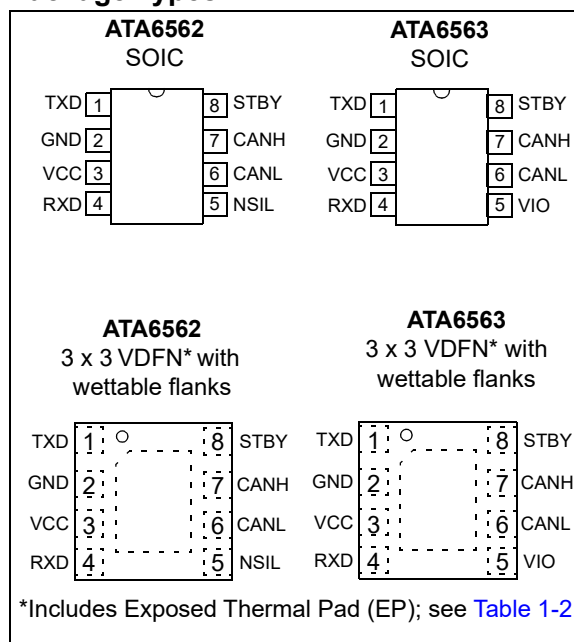

ATA6562/3

ATA6562/ATA6563 Family Members

Device	VIO Pin	NSIL	Grade 0	Grade 1	VDFN8	SOIC8	Description
ATA6562-GAQW0		X	X			X	Standby mode and Silent mode
ATA6562-GAQW1		X		X		X	Standby mode and Silent mode
ATA6562-GBQW0		X	X		X		Standby mode and Silent mode
ATA6562-GBQW1		X		X	X		Standby mode and Silent mode
ATA6563-GAQW0	X		X			X	Standby mode, VIO - pin for compatibility with 3.3V and 5V microcontroller
ATA6563-GAQW1	X			X		X	Standby mode, VIO - pin for compatibility with 3.3V and 5V microcontroller
ATA6563-GBQW0	X		X		X		Standby mode, VIO-pin for compatibility with 3.3V and 5V microcontroller
ATA6563-GBQW1	X			X	X		Standby mode, VIO - pin for compatibility with 3.3V and 5V microcontroller

Note: For ordering information, see the [Product Identification System](#) section.

Functional Block Diagram

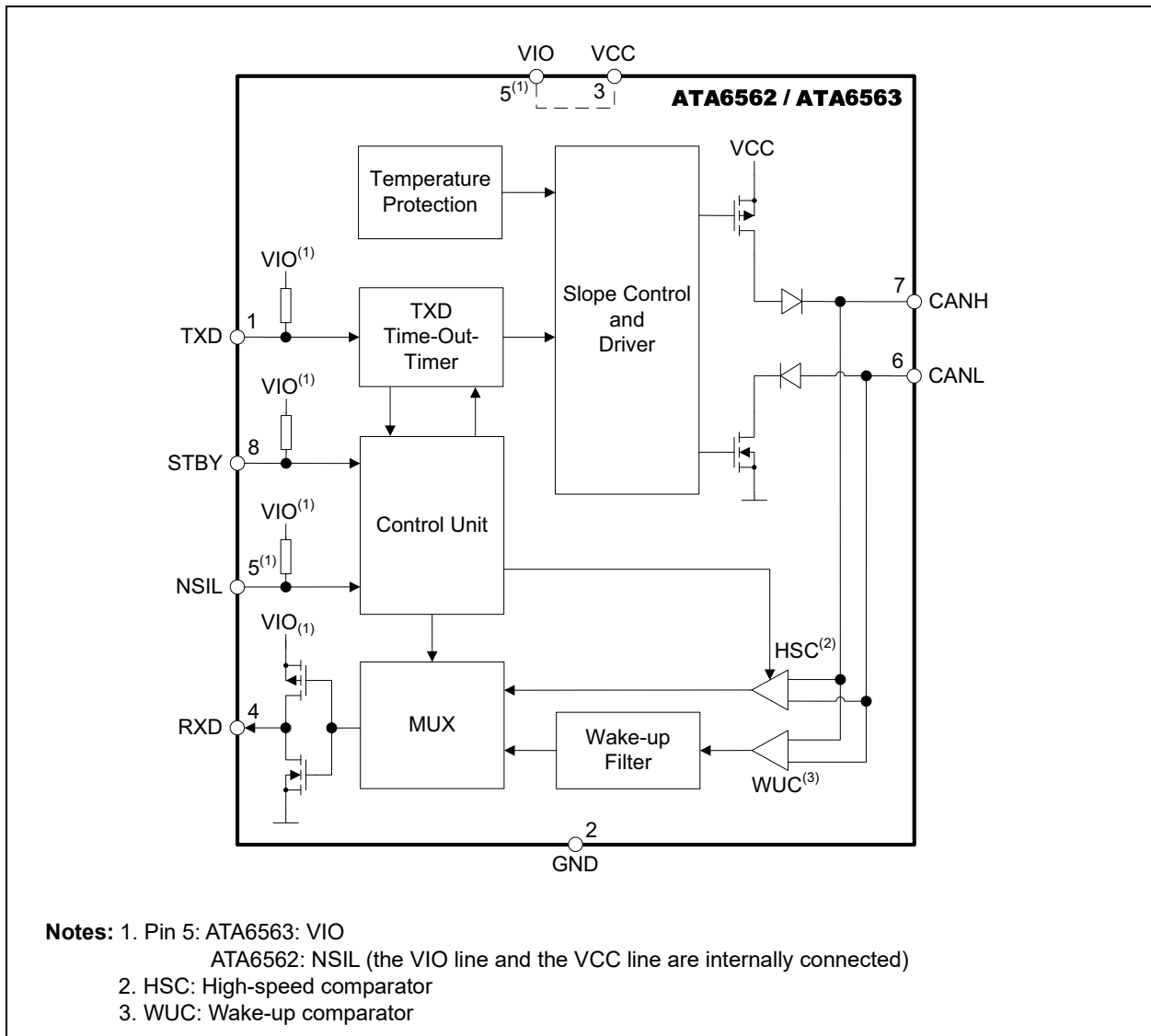

ATA6562/3

1.0 FUNCTIONAL DESCRIPTION

The ATA6562/ATA6563 is a stand-alone dual high-speed CAN transceiver compliant with the ISO 11898-2, ISO 11898-2: 2016, ISO 11898-5 and SAE J2962-2 CAN standards. It provides a very low current consumption in Standby mode and wake-up capability via the CAN bus. There are two versions available, only differing in the function of pin 5:

- ATA6562: The pin 5 is the control input for Silent mode NSIL, allowing the ATA6562 to only receive data but not send data via the bus. The output driver stage is disabled. The VIO line and the VCC line are internally connected, this sets the signal levels of the TXD, RXD, STBY, and NSIL pins to levels compatible with 5V microcontrollers.

- ATA6563: The pin 5 is the VIO pin and should be connected to the microcontroller supply voltage. This allows direct interfacing to microcontrollers with supply voltages down to 3V and adjusts the signal levels of the TXD, RXD, and STBY pins to the I/O levels of the microcontroller. The I/O ports are supplied by the VIO pin.

1.1 Operating Modes

Each of the transceivers supports three operating modes: Unpowered, Standby and Normal. The ATA6562 additionally has the Silent mode. These modes can be selected via the STBY and NSIL pin. See Figure 1-1 and Table 1-1 for a description of the operating modes.

FIGURE 1-1: OPERATING MODES

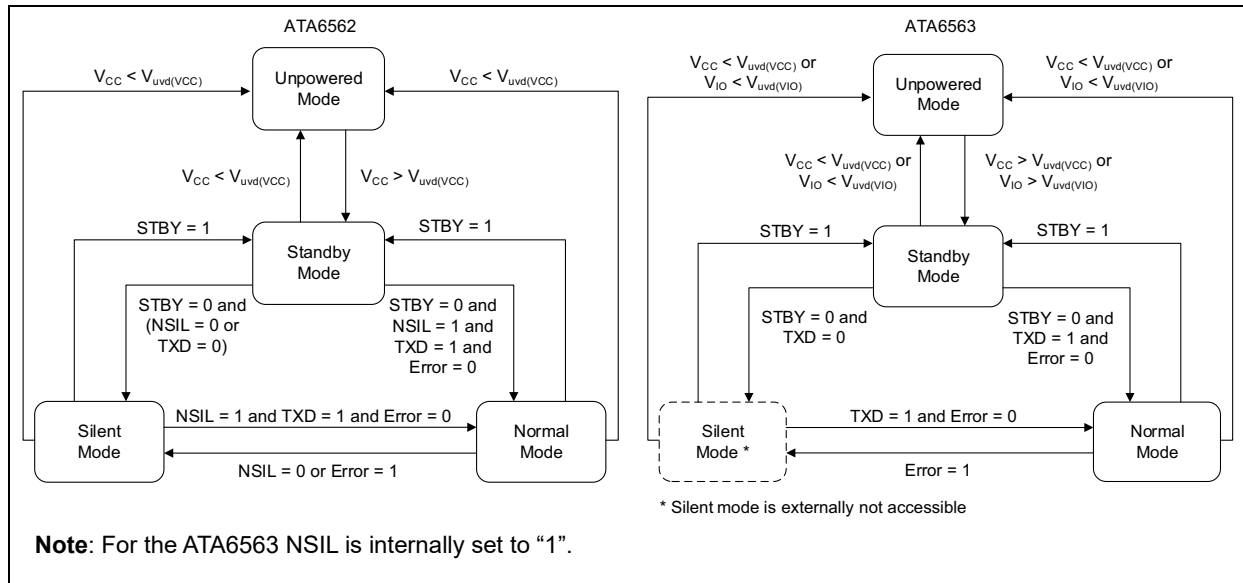

TABLE 1-1: OPERATING MODES

Mode	Inputs			Outputs	
	STBY	NSIL	PIN TXD	CAN Driver	Pin RXD
Unpowered	X ⁽³⁾	X ⁽³⁾	X ⁽³⁾	Recessive	Recessive
Standby	HIGH	X ⁽³⁾	X ⁽³⁾	Recessive	Active ⁽⁴⁾
Silent (only for ATA6562)	LOW	LOW	X ⁽³⁾	Recessive	Active ⁽¹⁾
Normal	LOW	HIGH ⁽²⁾	LOW	Dominant	LOW
	LOW	HIGH ⁽²⁾	HIGH	Recessive	HIGH

Note 1: LOW if the CAN bus is dominant, HIGH if the CAN bus is recessive.

2: Internally pulled up if not bonded out.

3: Irrelevant

4: Reflects the bus only for wake-up

1.1.1 NORMAL MODE

A low level on the STBY pin together with a high level on pin TXD selects the Normal mode. In this mode the transceiver is able to transmit and receive data via the

CANH and CANL bus lines (see [Functional Block Diagram](#)). The output driver stage is active and drives data from the TXD input to the CAN bus. The high-speed comparator (HSC) converts the analog

data on the bus lines into digital data which is output to pin RXD. The bus biasing is set to $V_{VCC}/2$ and the undervoltage monitoring of VCC is active.

The slope of the output signals on the bus lines is controlled and optimized in a way that guarantees the lowest possible electromagnetic emission (EME).

To switch the device in normal operating mode, set the STBY pin to low and the TXD pin to high (see Table 1-1 and Figure 1-2). The STBY pin provides a pull-up resistor to VIO, thus ensuring a defined level if the pin is open.

Please note that the device cannot enter Normal mode as long as TXD is at ground level.

The switching into Normal mode is depicted in the following two figures.

FIGURE 1-2: SWITCHING FROM STANDBY MODE TO NORMAL MODE (NSIL = HIGH)

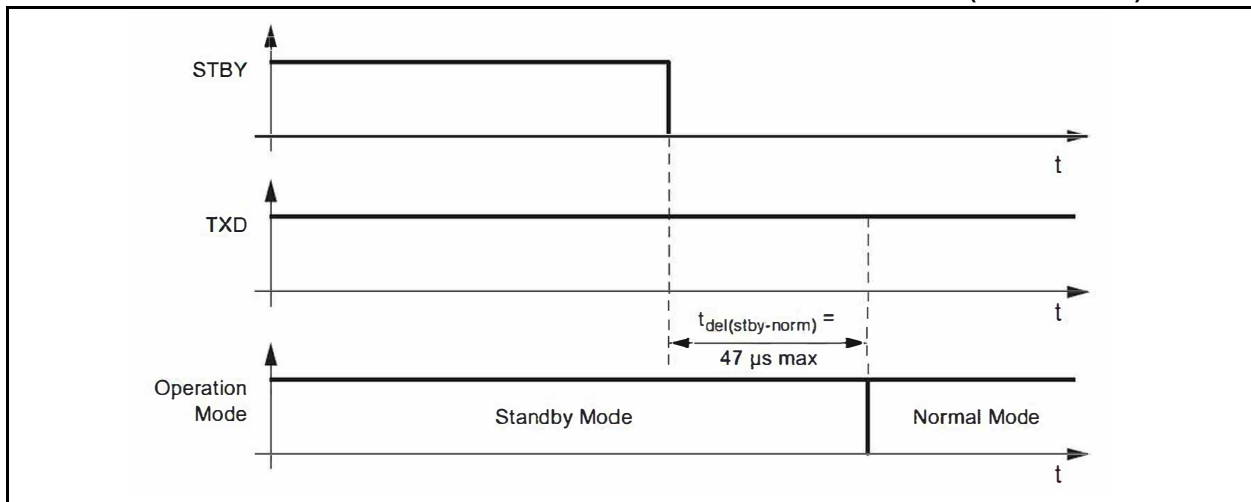
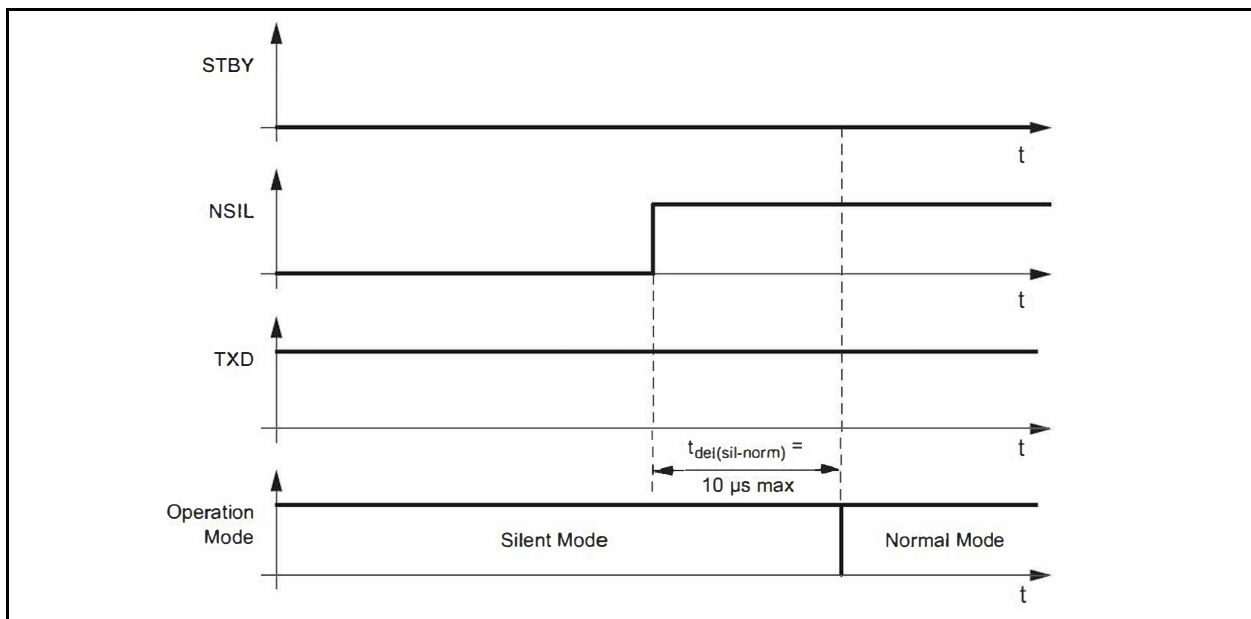

FIGURE 1-3: SWITCHING FROM SILENT MODE TO NORMAL MODE



1.1.2 SILENT MODE (ONLY WITH THE ATA6562)

A low level on the NSIL pin (available on pin 5) and on the STBY pin selects Silent mode. This receive-only

mode can be used to test the connection of the bus medium. In Silent mode the ATA6562 can still receive data from the bus, but the transmitter is disabled and therefore no data can be sent to the CAN bus. The bus pins are released to recessive state. All other IC

ATA6562/3

functions, including the high-speed comparator (HSC), continue to operate as they do in Normal mode. Silent mode can be used to prevent a faulty CAN controller from disrupting all network communications.

1.1.3 STANDBY MODE

A high level on the STBY pin selects Standby mode. In this mode the transceiver is not able to transmit or correctly receive data via the bus lines. The transmitter and the high-speed comparator (HSC) are switched off to reduce current consumption.

For ATA6562 only: In the event the NSIL input pin is set to low in Standby mode, the internal pull-up resistor causes an additional quiescent current from VIO to GND. Microchip recommends setting the NSIL pin to high in Standby mode.

1.1.3.1 Remote Wake-up via the CAN Bus

In Standby mode the bus lines are biased to ground to reduce current consumption to a minimum. The ATA6562/ATA6563 monitors the bus lines for a valid

wake-up pattern as specified in the ISO 11898-2: 2016. This filtering helps to avoid spurious wake-up events, which would be triggered by scenarios such as a dominant clamped bus or by a dominant phase due to noise, spikes on the bus, automotive transients or EMI.

The wake-up pattern consists of at least two consecutive dominant bus levels for a duration of at least t_{Filter} , each separated by a recessive bus level with a duration of at least t_{Filter} . Dominant or recessive bus levels shorter than t_{Filter} are always being ignored. The complete dominant-recessive-dominant pattern as shown in Figure 1-4, must be received within the bus wake-up time-out time t_{Wake} to be recognized as a valid wake-up pattern. Otherwise, the internal wake-up logic is reset and then the complete wake-up pattern must be retransmitted to trigger a wake-up event. Pin RXD remains at high level until a valid wake-up event has been detected.

During Normal mode, at a VCC undervoltage condition or when the complete wake-up pattern is not received within t_{Wake} , no wake-up is signalled at the RXD pin.

FIGURE 1-4: TIMING OF THE BUS WAKE-UP PATTERN (WUP) IN STANDBY MODE

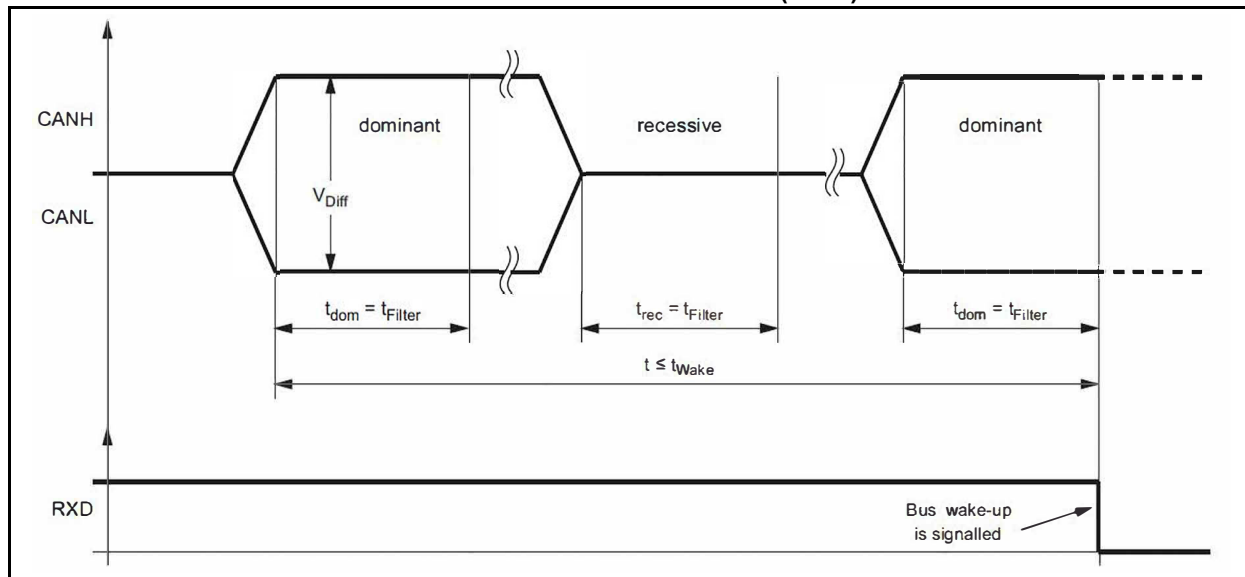

When a valid CAN wake-up pattern is detected on the bus, the RXD pin switches to low to signal a wake-up request. A transition to Normal mode is not triggered until the STBY pin is forced back to low by the microcontroller.

1.2 Fail-safe Features

1.2.1 TXD DOMINANT TIME-OUT FUNCTION

A TXD dominant time-out timer is started when the TXD pin is set to low. If the low state on the TXD pin persists for longer than $t_{to(dom)TXD}$, the transmitter is disabled, releasing the bus lines to recessive state. This function prevents a hardware and/or software

application failure from driving the bus lines to a permanent dominant state (blocking all network communications). The TXD dominant time-out timer is reset when the TXD pin is set to high. If the low state on the TXD pin was longer than $t_{to(dom)TXD}$, then the TXD pin has to be set to high longer 4 μ s in order to reset the TXD dominant time-out timer..

1.2.2 INTERNAL PULL-UP STRUCTURE AT THE TXD AND STBY INPUT PINS

The TXD and STBY pins have an internal pull-up to VIO. This ensures a safe, defined state in case one or both pins are left floating. Pull-up currents flow in these

pins in all states, meaning all pins should be in high state during Standby mode to minimize the current consumption.

1.2.3 UNDERVOLTAGE DETECTION ON PIN VCC

If V_{VCC} or V_{VIO} drops below its undervoltage detection levels ($V_{uvd(VCC)}$ and $V_{uvd(VIO)}$) (see Section 2.0, Electrical Characteristics), the transceiver switches off and disengages from the bus until V_{VCC} and V_{VIO} has recovered. The low-power wake-up comparator is only switched off during a VCC and VIO undervoltage. The logic state of the STBY pin is ignored until the V_{VCC} voltage or V_{VIO} voltage has recovered.

1.2.4 BUS WAKE UP ONLY AT DEDICATED WAKE-UP PATTERN

Due to the implementation of the wake-up filtering the ATA6562/ATA6563 does not wake-up when the bus is in a long dominant phase, it only wakes up at a dedicated wake-up pattern as specified in the ISO 11898-2: 2016. This means for a valid wake-up at least

two consecutive dominant bus levels for a duration of at least t_{Filter} , each separated by a recessive bus level with a duration of at least t_{Filter} must be received via the bus. Dominant or recessive bus levels shorter than t_{Filter} are always being ignored. The complete dominant-recessive-dominant pattern as shown in Figure 1-4, must be received within the bus wake-up time-out time t_{Wake} to be recognized as a valid wake-up pattern. This filtering leads to a higher robustness against EMI and transients and reduces therefore the risk of an unwanted bus wake-up significantly.

1.2.5 OVERTEMPERATURE PROTECTION

The output drivers are protected against overtemperature conditions. If the junction temperature exceeds the shutdown junction temperature, T_{Jsd} , the output drivers are disabled until the junction temperature drops below T_{Jsd} and pin TXD is at high level again. The TXD condition ensures that output driver oscillations due to temperature drift are avoided.

FIGURE 1-5: RELEASE OF TRANSMISSION AFTER OVERTEMPERATURE CONDITION

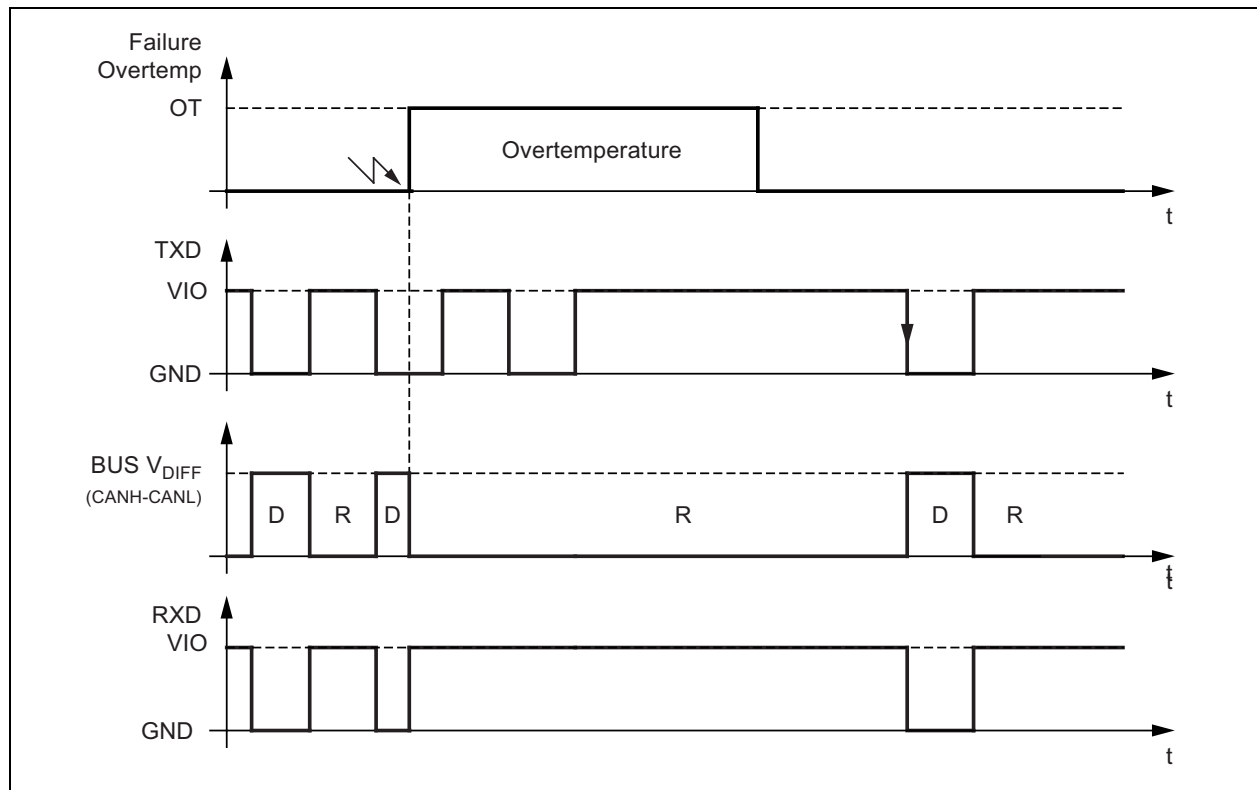

1.2.6 SHORT-CIRCUIT PROTECTION OF THE BUS PINS

The CANH and CANL bus outputs are short-circuit protected, either against GND or a positive supply voltage. A current-limiting circuit protects the transceiver against damage. If the device is heating up

due to a continuous short on CANH or CANL, the internal overtemperature protection switches the bus transmitter off.

ATA6562/3

1.2.7 RXD RECESSIVE CLAMPING

This fail-safe feature prevents the controller from sending data on the bus if its RXD is clamped to HIGH (e.g., recessive). That is, if the RXD pin cannot signalize a dominant bus condition because it is e.g., shorted to VCC, the transmitter within ATA6562/ATA6563 is disabled to avoid possible data collisions on the bus. In Normal and Silent mode (only ATA6562), the device permanently compares the state

of the high-speed comparator (HSC) with the state of the RXD pin. If the HSC indicates a dominant bus state for more than t_{RC_det} without the RXD pin doing the same, a recessive clamping situation is detected and the transceiver is forced into Silent mode. This Fail-safe mode is released by either entering Standby or Unpowered mode or if the RXD pin is showing a dominant (e.g., low) level again.

FIGURE 1-6: RXD RECESSIVE CLAMPING DETECTION

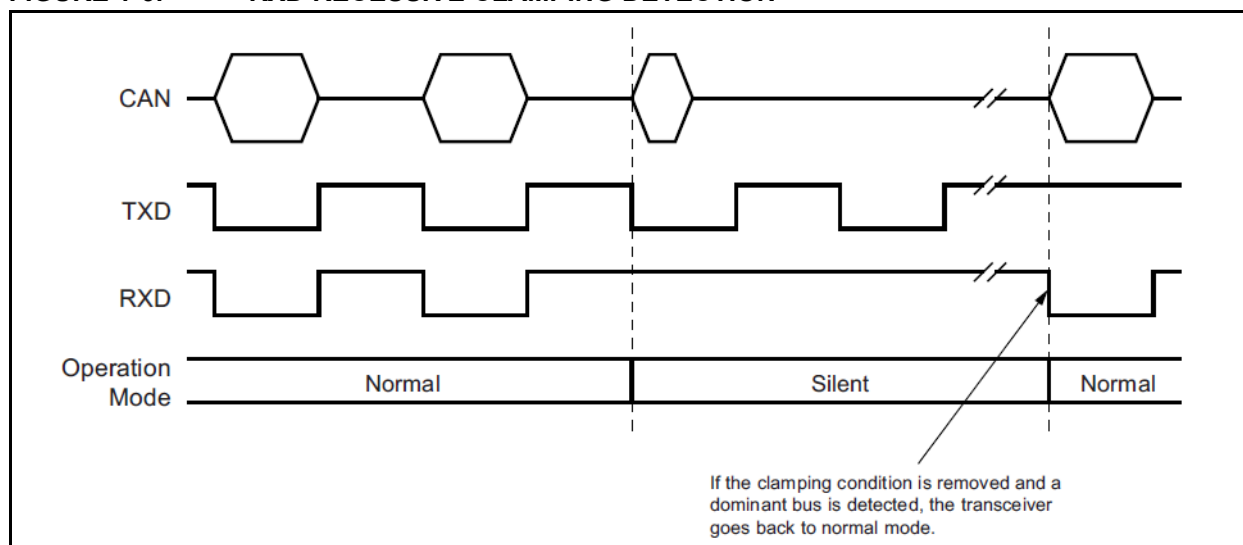

1.3 Pin Description

The descriptions of the pins are listed in [Table 1-2](#).

TABLE 1-2: PIN FUNCTION TABLE

ATA6562		ATA6563		Pin Name	Description
SOIC8	VDFN8	SOIC8	VDFN8		
1	1	1	1	TXD	Transmit data input
2	2	2	2	GND	Ground1 supply
3	3	3	3	VCC	Supply voltage
4	4	4	4	RXD	Receive data output; reads out data from the bus lines
—	—	5	5	VIO	Supply voltage for I/O level adapter
5	5	—	—	NSIL	Silent mode control input (low active);
6	6	6	6	CANL	Low-level CAN bus line
7	7	7	7	CANH	High-level CAN bus line
8	8	8	8	STBY	Standby mode control input
—	9	—	9	EP	Exposed Thermal Pad: Heat slug, internally connected to the GND pin.

1.4 Typical Application

Typical Application ATA6562

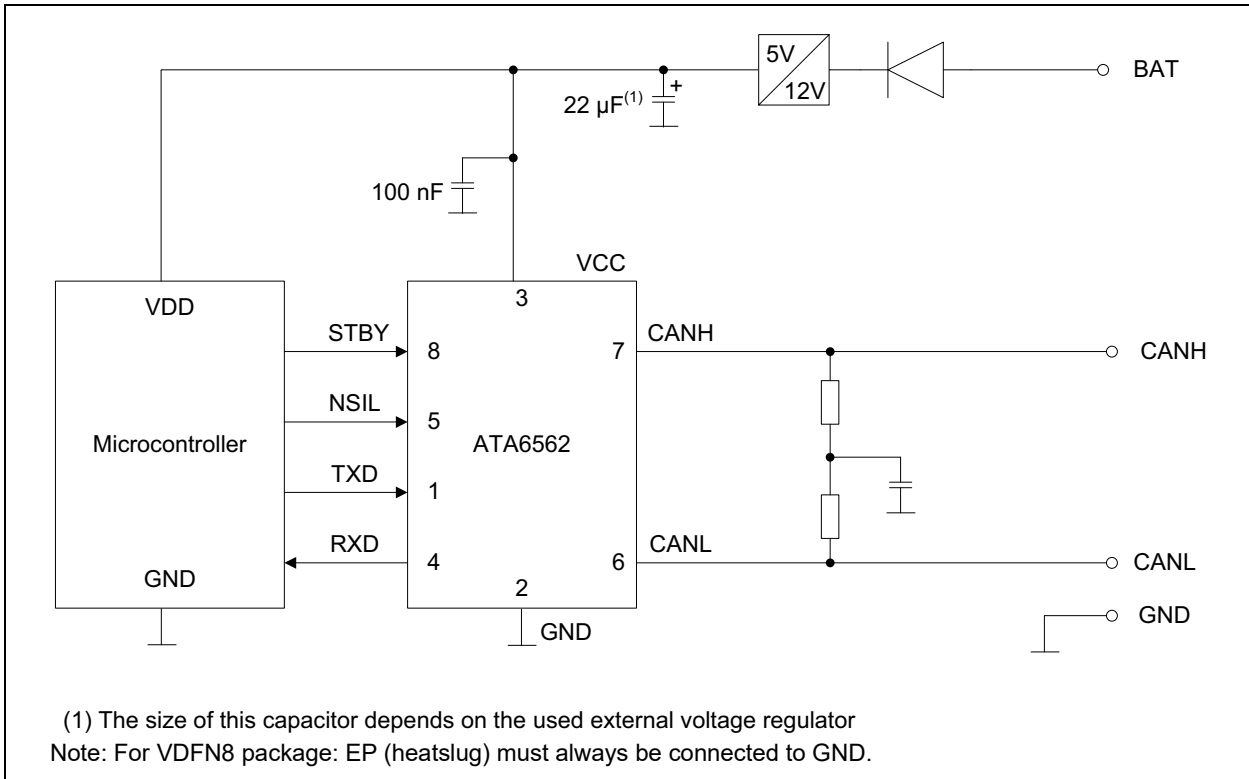

Typical Application ATA6563

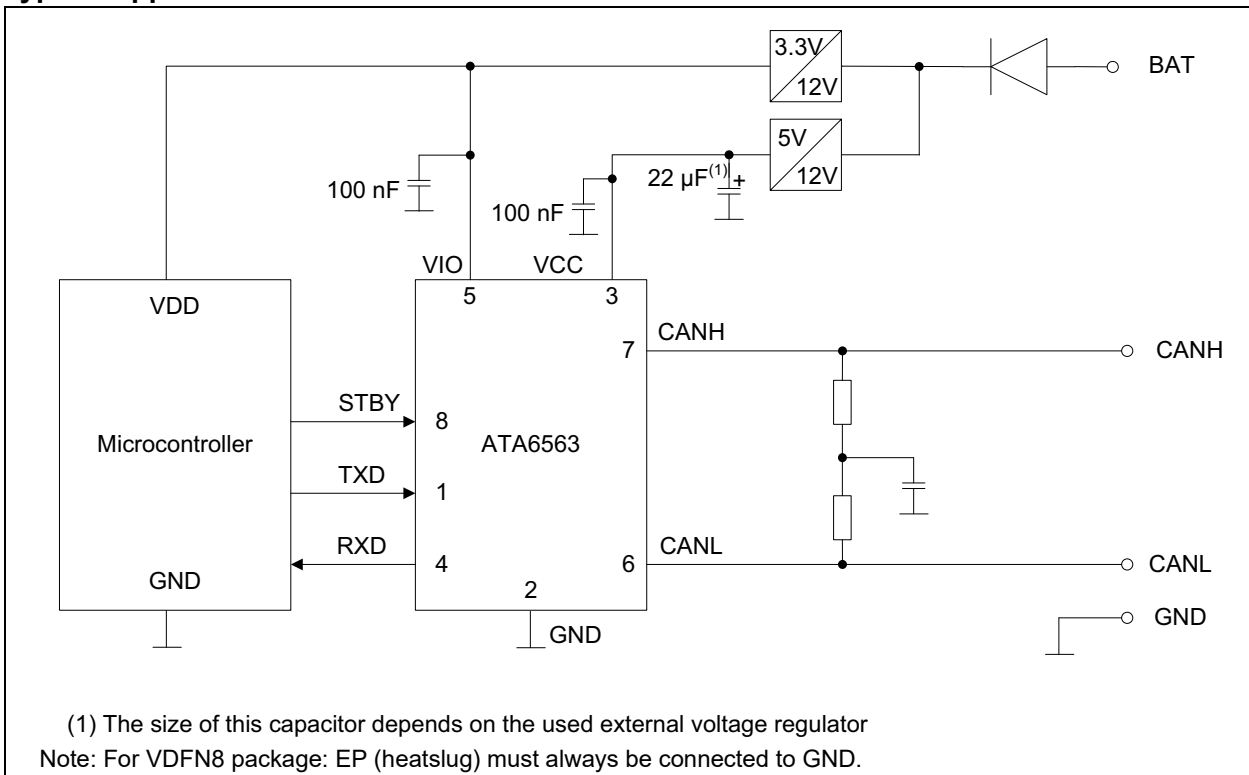

ATA6562/3

2.0 ELECTRICAL CHARACTERISTICS

Absolute Maximum Ratings (†)

DC Voltage at CANH, CANL (V_{CANH} , V_{CANL})	-27 to +42V
Transient Voltage at CANH, CANL (according to ISO 7637 part 2) (V_{CANH} , V_{CANL})	-150 to +100V
Max. differential bus voltage (V_{Diff})	-5 to +18V
DC voltage on all other pins (V_X)	-0.3 to +5.5V
ESD according to IBEE CAN EMC - Test specification following IEC 61000-4-2 — Pin CANH, CANL	±8 kV
ESD (HBM following STM5.1 with 1.5 kΩ/100 pF) - Pins CANH, CANL to GND	±6 kV
Component Level ESD (HBM according to ANSI/ESD STM5.1, JESD22-A114, AEC-Q100 (002))	±4 kV
CDM ESD STM 5.3.1	±750V
ESD machine model AEC-Q100-RevF(003)	±200V
Virtual Junction Temperature (T_{VJ})	-40 to +175°C
Storage Temperature Range (T_{stg})	-55°C to +150°C

† **Notice:** Stresses above those listed under “Maximum Ratings” may cause permanent damage to the device. This is a stress rating only and functional operation of the device at those or any other conditions above those indicated in the operation listings of this specification is not implied. Exposure to maximum rating conditions for extended periods may affect device reliability.

TABLE 2-1: ELECTRICAL CHARACTERISTICS

Electrical Specifications: The values below are valid for each of the two identical integrated CAN transceivers.						
Grade 1: $T_{amb} = -40^{\circ}\text{C}$ to $+125^{\circ}\text{C}$ and Grade 0: $T_{amb} = -40^{\circ}\text{C}$ to $+150^{\circ}\text{C}$; $T_{VJ} \leq 170^{\circ}\text{C}$; $V_{VCC} = 4.5\text{V}$ to 5.5V ; $R_L = 60\Omega$, $C_L = 100\text{pF}$ unless specified otherwise; all voltages are defined in relation to ground; positive currents flow into the IC.						
Parameters	Sym.	Min.	Typ.	Max.	Units	Conditions
Supply, Pin VCC						
Supply Voltage	V_{VCC}	4.5	—	5.5	V	
Supply Current in Silent Mode	I_{VCC_sil}	1.9	2.5	3.2	mA	Silent mode, $V_{TXD} = V_{VIO}$
Supply Current in Normal Mode	I_{VCC_rec}	2	—	5	mA	recessive, $V_{TXD} = V_{VIO}$
	I_{VCC_dom}	30	50	70	mA	dominant, $V_{TXD} = 0\text{V}$
	I_{VCC_short}	—	—	85	mA	short between CANH and CANL (Note 1)
Supply Current in Standby Mode	I_{VCC_STBY}	—	—	12	μA	$V_{CC} = V_{IO}$, $V_{TXD} = V_{NSIL} = V_{VIO}$
	I_{VCC_STBY}	—	7	—	μA	$T_a = 25^{\circ}\text{C}$ (Note 3)
Undervoltage Detection Threshold on Pin VCC	$V_{uvd(VCC)}$	2.75	—	4.5	V	
I/O Level Adapter Supply, Pin VIO (only with the ATA6563)						
Supply voltage on pin VIO	V_{VIO}	2.8	—	5.5	V	
Supply current on pin VIO	I_{VIO_rec}	10	80	250	μA	Normal and Silent mode recessive, $V_{TXD} = V_{VIO}$
	I_{VIO_dom}	50	350	500	μA	Normal and Silent mode dominant, $V_{TXD} = 0\text{V}$
	I_{VIO_STBY}	—	—	1	μA	Standby mode

- Note 1:** 100% correlation tested
Note 2: Characterized on samples
Note 3: Design parameter

TABLE 2-1: ELECTRICAL CHARACTERISTICS (CONTINUED)

Electrical Specifications: The values below are valid for each of the two identical integrated CAN transceivers.
 Grade 1: $T_{amb} = -40^{\circ}\text{C}$ to $+125^{\circ}\text{C}$ and Grade 0: $T_{amb} = -40^{\circ}\text{C}$ to $+150^{\circ}\text{C}$; $T_{vj} \leq 170^{\circ}\text{C}$; $V_{VCC} = 4.5\text{V}$ to 5.5V ; $R_L = 60\Omega$, $C_L = 100\text{ pF}$ unless specified otherwise; all voltages are defined in relation to ground; positive currents flow into the IC.

Parameters	Sym.	Min.	Typ.	Max.	Units	Conditions
Undervoltage detection threshold on pin VIO	$V_{uvd(VIO)}$	1.3	—	2.7	V	
Mode Control Input, Pin NSIL and STBY						
High-level Input Voltage	V_{IH}	$0.7 \times V_{VIO}$	—	$V_{VIO} + 0.3$	V	
Low-level Input Voltage	V_{IL}	-0.3	—	$0.3 \times V_{VIO}$	V	
Pull-up Resistor to VCC	R_{pu}	75	125	175	k Ω	$V_{STBY} = 0\text{V}$, $V_{NSIL} = 0\text{V}$
High-level Leakage Current	I_L	-2	—	+2	μA	$V_{STBY} = V_{VIO}$, $V_{NSIL} = V_{VIO}$
CAN Transmit Data Input, Pin TXD						
High-level Input Voltage	V_{IH}	$0.7 \times V_{VIO}$	—	$V_{VIO} + 0.3$	V	
Low-level Input Voltage	V_{IL}	-0.3	—	$0.3 \times V_{VIO}$	V	
Pull-up Resistor to VCC	R_{TXD}	20	35	50	k Ω	$V_{TXD} = 0\text{V}$
High-level Leakage Current	I_{TXD}	-2	—	+2	μA	Normal mode, $V_{TXD} = V_{VIO}$
Input Capacitance	C_{TXD}	—	5	10	pF	Note 3
CAN Receive Data Output, Pin RXD						
High-level Output Current	I_{OH}	-8	—	-1	mA	Normal mode, $V_{RXD} = V_{VIO} - 0.4\text{V}$, $V_{VIO} = V_{VCC}$
Low-level Output Current, Bus Dominant	I_{OL}	2	—	12	mA	Normal mode, $V_{RXD} = 0.4\text{V}$, bus dominant
Bus Lines, Pins CANH and CANL						
Single Ended Dominant Output Voltage	$V_{O(dom)}$	2.75	3.5	4.5	V	$V_{TXD} = 0\text{V}$, $t < t_{to(dom)TXD}$ $R_L = 50\Omega$ to 65Ω pin CANH (Note 1)
		0.5	1.5	2.25	V	$V_{TXD} = 0\text{V}$, $t < t_{to(dom)TXD}$ $R_L = 50\Omega$ to 65Ω pin CANL (Note 1)
Transmitter Voltage Symmetry	V_{Sym}	0.9	1.0	1.1		$V_{Sym} = (V_{CANH} + V_{CANL}) / V_{VCC}$. Split Termination, $R_L = 2 \times 30\Omega$, $C_{Split} = 4.7\text{ nF}$ (Note 3)
Bus Differential Output Voltage	V_{Diff}	1.5	—	3	V	$V_{TXD} = 0\text{V}$, $t < t_{to(dom)TXD}$ $R_L = 45\Omega$ to 65Ω
		1.5	—	3.3	V	$R_L = 70\Omega$ (Note 3)
		1.5	—	5	V	$R_L = 2240\Omega$ (Note 3)
		-50	—	+50	mV	Normal and Silent mode: $V_{VCC} = 4.75\text{V}$ to 5.25V $V_{TXD} = V_{VIO}$, recessive, no load
		-200	—	+200	mV	Standby mode: $V_{VCC} = 4.75\text{V}$ to 5.25V $V_{TXD} = V_{VIO}$, recessive, no load
Single Ended Recessive Output Voltage	$V_{O(rec)}$	2	0.5* V_{VCC}	3	V	Normal and Silent mode, $V_{TXD} = V_{VIO}$, no load
	$V_{O(rec)}$	-0.1	—	+0.1	V	Standby mode, $V_{TXD} = V_{VIO}$, no load

- Note 1:** 100% correlation tested
Note 2: Characterized on samples
Note 3: Design parameter

ATA6562/3

TABLE 2-1: ELECTRICAL CHARACTERISTICS (CONTINUED)

Electrical Specifications: The values below are valid for each of the two identical integrated CAN transceivers.
 Grade 1: $T_{amb} = -40^{\circ}\text{C}$ to $+125^{\circ}\text{C}$ and Grade 0: $T_{amb} = -40^{\circ}\text{C}$ to $+150^{\circ}\text{C}$; $T_{vj} \leq 170^{\circ}\text{C}$; $V_{VCC} = 4.5\text{V}$ to 5.5V ; $R_L = 60\Omega$, $C_L = 100\text{pF}$ unless specified otherwise; all voltages are defined in relation to ground; positive currents flow into the IC.

Parameters	Sym.	Min.	Typ.	Max.	Units	Conditions
Differential Receiver Threshold Voltage	$V_{th(RX)dif}$	0.5	0.7	0.9	V	Normal and Silent mode (HSC), $V_{cm(CAN)} = -27\text{V}$ to $+27\text{V}$
	$V_{th(RX)dif}$	0.4	0.7	1.1	V	Standby mode (WUC), $V_{cm(CAN)} = -27\text{V}$ to $+27\text{V}$ (Note 1)
Differential Receiver Hysteresis Voltage	$V_{hys(RX)dif}$	50	120	200	mV	Normal and Silent mode (HSC), $V_{cm(CAN)} = -27\text{V}$ to $+27\text{V}$ (Note 1)
Dominant Output Current	$I_{IO(dom)}$	-75	—	-35	mA	$V_{TXD} = 0\text{V}$, $t < t_{to(dom)TXD}$, $V_{VCC} = 5\text{V}$ pin CANH, $V_{CANH} = -5\text{V}$
		35	—	75	mA	$V_{TXD} = 0\text{V}$, $t < t_{to(dom)TXD}$, $V_{VCC} = 5\text{V}$ pin CANL, $V_{CANL} = +40\text{V}$
Recessive Output Current	$I_{IO(rec)}$	-5	—	+5	mA	Normal and Silent mode, $V_{TXD} = V_{VIO}$, no load, $V_{CANH} = V_{CANL} = -27\text{V}$ to $+32\text{V}$
Leakage Current	$I_{IO(leak)}$	-5	0	+5	μA	$V_{VCC} = V_{VIO} = 0\text{V}$, $V_{CANH} = V_{CANL} = 5\text{V}$
	$I_{IO(leak)}$	-5	0	+5	μA	$V_{CC} = V_{IO}$ connected to GND with $R = 47\text{k}\Omega$ $V_{CANH} = V_{CANL} = 5\text{V}$ (Note 3)
Input Resistance	R_i	9	15	28	$\text{k}\Omega$	$V_{CANH} = V_{CANL} = 4\text{V}$
	R_i	9	15	28	$\text{k}\Omega$	$-2\text{V} \leq V_{CANH} \leq +7\text{V}$, $-2\text{V} \leq V_{CANL} \leq +7\text{V}$ (Note 3)
Input Resistance Deviation	ΔR_i	-1	0	+1	%	Between CANH and CANL $V_{CANH} = V_{CANL} = 4\text{V}$ (Note 1)
	ΔR_i	-1	0	+1	%	Between CANH and CANL $-2\text{V} \leq V_{CANH} \leq +7\text{V}$, $-2\text{V} \leq V_{CANL} \leq +7\text{V}$ (Note 3)
Differential Input Resistance	$R_{i(dif)}$	18	30	56	$\text{k}\Omega$	$V_{CANH} = V_{CANL} = 4\text{V}$ (Note 1)
	$R_{i(dif)}$	18	30	56	$\text{k}\Omega$	$-2\text{V} \leq V_{CANH} \leq +7\text{V}$, $-2\text{V} \leq V_{CANL} \leq +7\text{V}$ (Note 3)
Common-mode Input Capacitance	$C_{i(cm)}$	—	—	20	pF	$f = 500\text{kHz}$, CANH and CANL referred to GND (Note 3)
Differential Input Capacitance	$C_{i(dif)}$	—	—	10	pF	$f = 500\text{kHz}$, between CANH and CANL (Note 3)
Differential Bus Voltage Range for RECESSIVE State Detection	V_{Diff_rec}	-3	—	+0.5	V	Normal and Silent mode (HSC) $-27\text{V} \leq V_{CANH} \leq +27\text{V}$, $-27\text{V} \leq V_{CANL} \leq +27\text{V}$ (Note 3)
	V_{Diff_rec}	-3	—	+0.4	V	Standby mode (WUC) $-27\text{V} \leq V_{CANH} \leq +27\text{V}$, $-27\text{V} \leq V_{CANL} \leq +27\text{V}$ (Note 3)

- Note 1:** 100% correlation tested
Note 2: Characterized on samples
Note 3: Design parameter

TABLE 2-1: ELECTRICAL CHARACTERISTICS (CONTINUED)

Electrical Specifications: The values below are valid for each of the two identical integrated CAN transceivers.
 Grade 1: $T_{amb} = -40^{\circ}\text{C}$ to $+125^{\circ}\text{C}$ and Grade 0: $T_{amb} = -40^{\circ}\text{C}$ to $+150^{\circ}\text{C}$; $T_{vj} \leq 170^{\circ}\text{C}$; $V_{VCC} = 4.5\text{V}$ to 5.5V ; $R_L = 60\Omega$, $C_L = 100\text{pF}$ unless specified otherwise; all voltages are defined in relation to ground; positive currents flow into the IC.

Parameters	Sym.	Min.	Typ.	Max.	Units	Conditions
Differential Bus Voltage Range for DOMINANT State Detection	V_{Diff_dom}	0.9	—	8.0	V	Normal and Silent mode (HSC) $-27\text{V} \leq V_{CANH} \leq +27\text{V}$, $-27\text{V} \leq V_{CANL} \leq +27\text{V}$ (Note 3)
	V_{Diff_dom}	1.15	—	8.0	V	Standby mode (WUC) $-27\text{V} \leq V_{CANH} \leq +27\text{V}$, $-27\text{V} \leq V_{CANL} \leq +27\text{V}$ (Note 3)
Transceiver Timing, Pins CANH, CANL, TXD, and RXD, see Figure 2-1 and Figure 2-3						
Delay Time from TXD to Bus Dominant	$t_{d(TXD-busdom)}$	40	—	130	ns	Normal mode (Note 2)
Delay Time from TXD to Bus Recessive	$t_{d(TXD-busrec)}$	40	—	130	ns	Normal mode (Note 2)
Delay Time from Bus Dominant to RXD	$t_{d(busdom-RXD)}$	20	—	100	ns	Normal mode (Note 2)
Delay Time from Bus Recessive to RXD	$t_{d(busrec-RXD)}$	20	—	100	ns	Normal mode (Note 2)
Propagation Delay from TXD to RXD	$t_{PD(TXD-RXD)}$	40	—	210	ns	Normal mode, Rising edge at pin TXD $R_L = 60\Omega$, $C_L = 100\text{pF}$
		40	—	200	ns	Normal mode, Falling edge at pin TXD $R_L = 60\Omega$, $C_L = 100\text{pF}$
	$t_{PD(TXD-RXD)}$	—	—	300	ns	Normal mode, Rising edge at pin TXD $R_L = 150\Omega$, $C_L = 100\text{pF}$ Note 3
		—	—	300	ns	Normal mode, Falling edge at pin TXD $R_L = 150\Omega$, $C_L = 100\text{pF}$ Note 3
TXD Dominant Time-Out Time	$t_{to(dom)TXD}$	0.8	—	3	ms	$V_{TXD} = 0\text{V}$, Normal mode
Bus Wake-up Time-Out Time	t_{Wake}	0.8	—	3	ms	Standby mode
Min. Dominant/Recessive Bus Wake-up Time	t_{Filter}	0.5	3	3.8	μs	Standby mode
Delay Time for Standby Mode to Normal Mode Transition	$t_{del(stby-norm)}$	—	—	47	μs	Falling edge at pin STBY
Delay Time for Normal Mode to Standby Mode Transition	$t_{del(norm-stby)}$	—	—	5	μs	Rising edge at pin STBY Note 3
Delay time for Normal mode to Silent mode transition	$t_{del(norm-sil)}$	—	—	10	μs	Falling edge at pin NSIL STBY = LOW (Note 3)
Delay time for Silent mode to Normal mode transition	$t_{del(sil-norm)}$	—	—	10	μs	Rising edge at pin NSIL STBY = LOW (Note 3)

- Note 1:** 100% correlation tested
Note 2: Characterized on samples
Note 3: Design parameter

ATA6562/3

TABLE 2-1: ELECTRICAL CHARACTERISTICS (CONTINUED)

Electrical Specifications: The values below are valid for each of the two identical integrated CAN transceivers.
 Grade 1: $T_{amb} = -40^{\circ}\text{C}$ to $+125^{\circ}\text{C}$ and Grade 0: $T_{amb} = -40^{\circ}\text{C}$ to $+150^{\circ}\text{C}$; $T_{VJ} \leq 170^{\circ}\text{C}$; $V_{VCC} = 4.5\text{V}$ to 5.5V ; $R_L = 60\Omega$, $C_L = 100\text{pF}$ unless specified otherwise; all voltages are defined in relation to ground; positive currents flow into the IC.

Parameters	Sym.	Min.	Typ.	Max.	Units	Conditions
Delay time for Silent mode to Standby mode transition	$t_{del(sil-stby)}$	—	—	5	μs	Rising edge at pin STBY NSIL = LOW (Note 3)
Delay time for Standby mode to Silent mode transition	$t_{del(stby-sil)}$	—	—	47	μs	Rising edge at pin STBY NSIL = LOW (Note 3)
Debouncing Time for Recessive Clamping State Detection	t_{RC_det}	—	90	—	ns	$V(\text{CANH-CANL}) > 900\text{mV}$ RXD = high (Note 3)
Transceiver Timing for higher Bit Rates, Pins CANH, CANL, TXD, and RXD, see Figure 2-1 and Figure 2-3						
Recessive Bit Time on Pin RXD	$t_{Bit(RXD)}$	400	—	550	ns	Normal mode, $t_{Bit(TXD)} = 500\text{ ns}$ $R_L = 60\Omega$, $C_L = 100\text{ pF}$ (Note 1)
		120	—	220	ns	Normal mode, $t_{Bit(TXD)} = 200\text{ ns}$ $R_L = 60\Omega$, $C_L = 100\text{ pF}$
Recessive Bit Time on the Bus	$t_{Bit(Bus)}$	435	—	530	ns	Normal mode, $t_{Bit(TXD)} = 500\text{ ns}$ $R_L = 60\Omega$, $C_L = 100\text{ pF}$ (Note 1)
		155	—	210	ns	Normal mode, $t_{Bit(TXD)} = 200\text{ ns}$ $R_L = 60\Omega$, $C_L = 100\text{ pF}$
Receiver Timing Symmetry	Δt_{Rec}	-65	—	+40	ns	Normal mode, $t_{Bit(TXD)} = 500\text{ ns}$ $\Delta t_{Rec} = t_{Bit(RXD)} - t_{Bit(Bus)}$ $R_L = 60\Omega$, $C_L = 100\text{ pF}$ (Note 1)
		-45	—	+15	ns	Normal mode, $t_{Bit(TXD)} = 200\text{ ns}$ $\Delta t_{Rec} = t_{Bit(RXD)} - t_{Bit(Bus)}$ $R_L = 60\Omega$, $C_L = 100\text{ pF}$

- Note 1:** 100% correlation tested
Note 2: Characterized on samples
Note 3: Design parameter

TABLE 2-2: TEMPERATURE SPECIFICATIONS

Parameters	Sym.	Min.	Typ.	Max.	Units
Thermal Characteristics SOIC8					
Thermal resistance Virtual Junction to Ambient	R_{thVJA}	—	145	—	K/W
Thermal Shutdown of the Bus Drivers					
ATA6562-GAqw1, ATA6563-GAqw1 (Grade 1)	T_{VJsd}	150	—	195	$^{\circ}\text{C}$
ATA6562-GAqw0, ATA6563-GAqw0 (Grade 0)	T_{VJsd}	170	—	195	$^{\circ}\text{C}$
Thermal Shutdown Hysteresis	T_{VJsd_hys}	—	15	—	$^{\circ}\text{C}$
Thermal Characteristics VDFN8					
Thermal Resistance Virtual Junction to Heat Slug	R_{thVJC}	—	10	—	K/W
Thermal Resistance Virtual Junction to Ambient, where Heat Slug is soldered to PCB according to JEDEC	R_{thVJA}	—	50	—	K/W
Thermal Shutdown of the Bus Drivers					
ATA6562-GBqw1, ATA6563-GBqw1 (Grade 1)	T_{VJsd}	150	—	195	$^{\circ}\text{C}$
ATA6562-GBqw0, ATA6563-GBqw0 (Grade 0)	T_{VJsd}	170	—	195	$^{\circ}\text{C}$
Thermal Shutdown Hysteresis	T_{VJsd_hys}	—	15	—	$^{\circ}\text{C}$

FIGURE 2-1: TIMING TEST CIRCUIT FOR THE ATA6562/3 CAN TRANSCEIVER

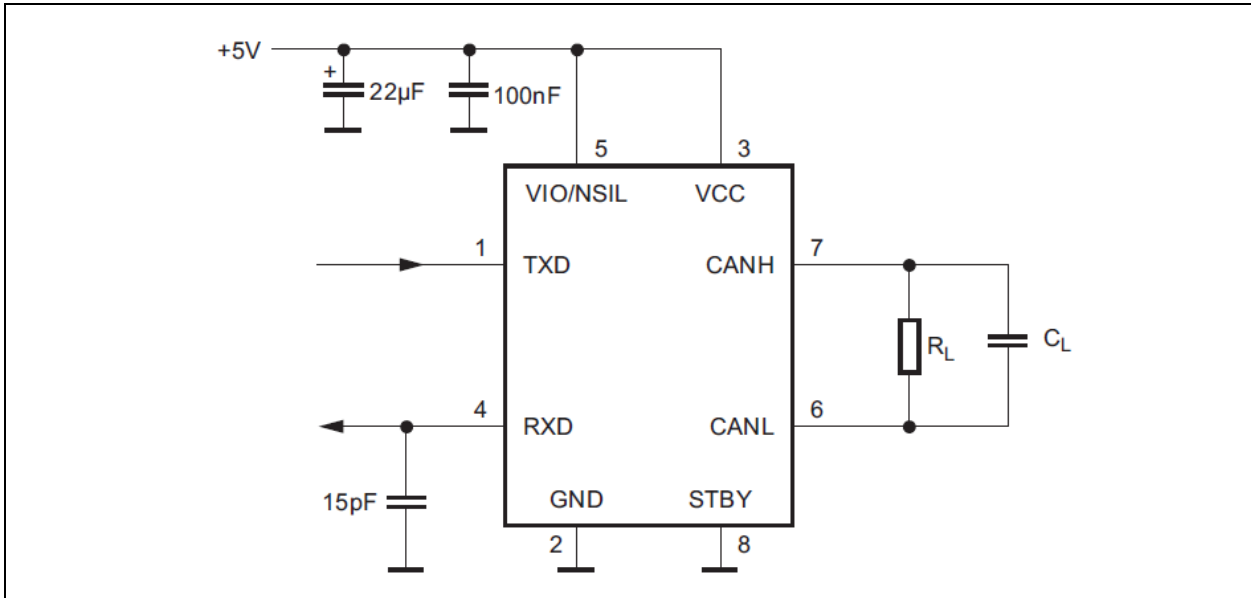

FIGURE 2-2: CAN TRANSCEIVER TIMING DIAGRAM 1

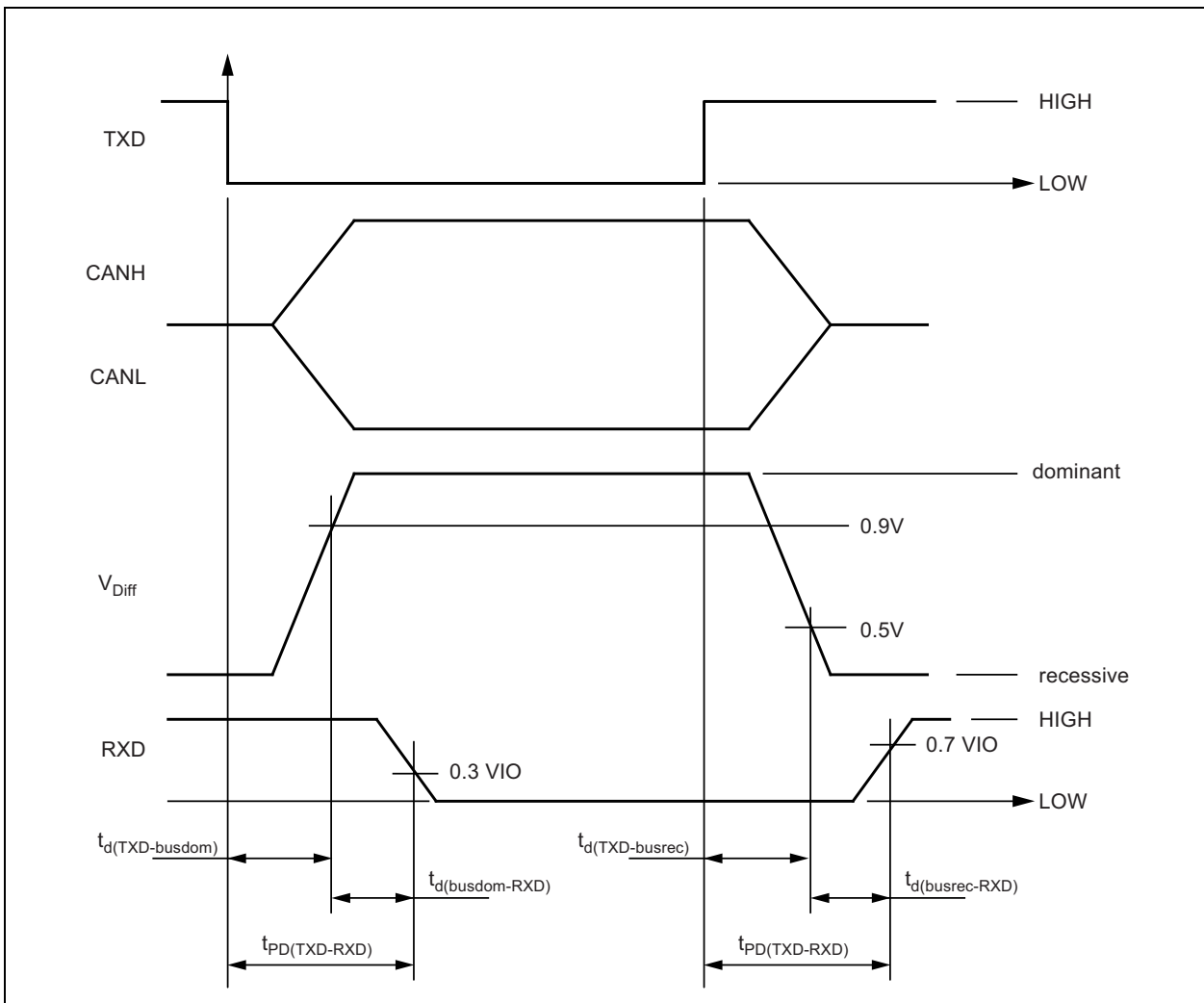
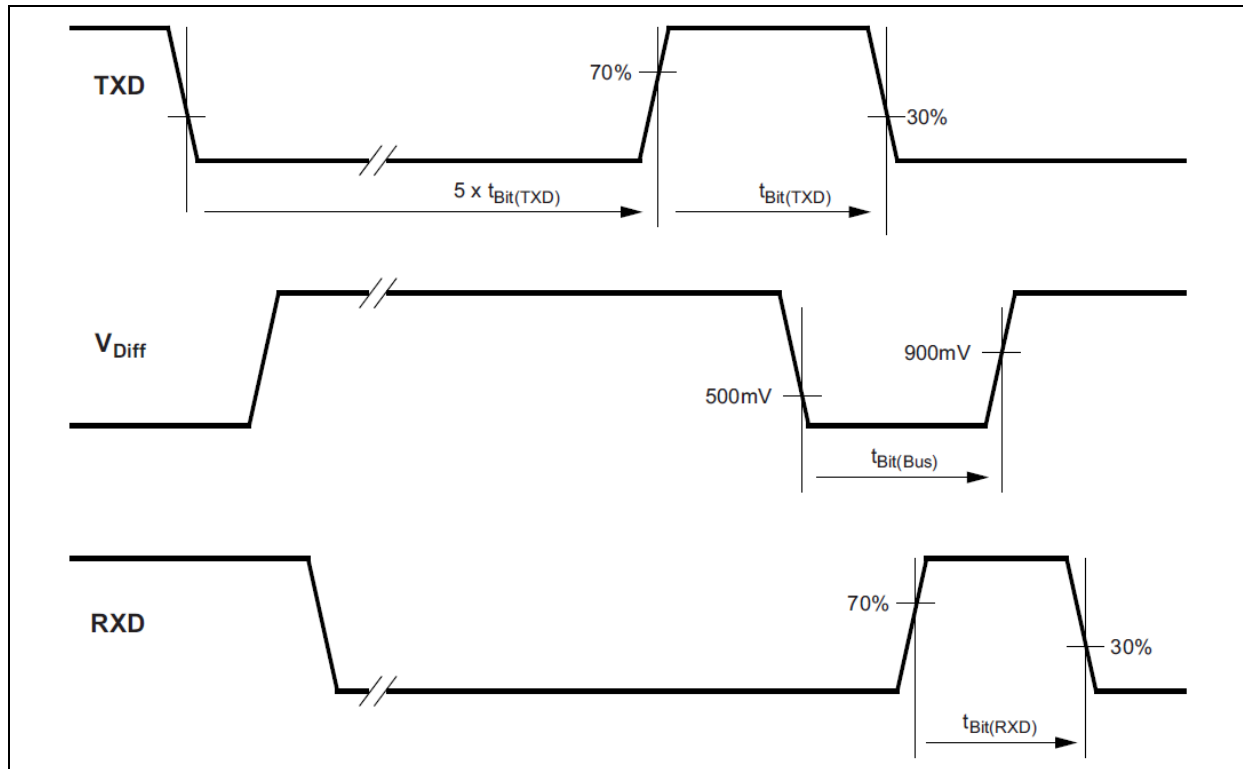

FIGURE 2-3: CAN TRANSCEIVER TIMING DIAGRAM 2



3.0 PACKAGING INFORMATION

Package Marking Information

8-Lead SOIC

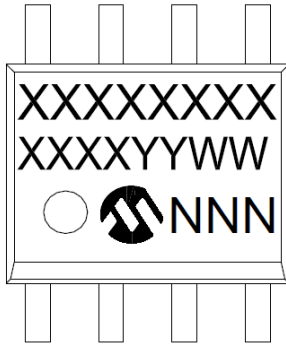

Example
ATA6562 Grade 0

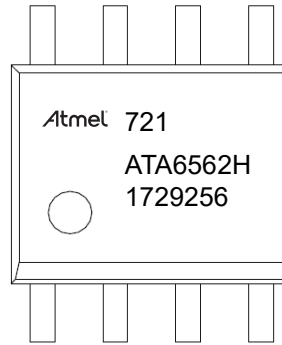

Example
ATA6562 Grade 1

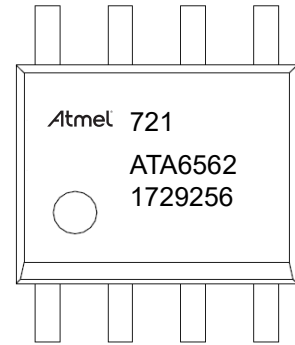

Example
ATA6563 Grade 0

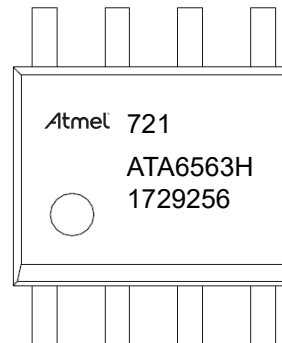

Example
ATA6563 Grade 1

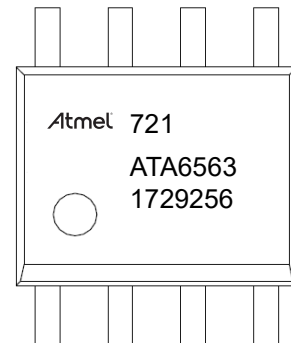

Legend:	XX...X	Customer-specific information
	Y	Year code (last digit of calendar year)
	YY	Year code (last 2 digits of calendar year)
	WW	Week code (week of January 1 is week '01')
	NNN	Alphanumeric traceability code
	(e3)	Pb-free JEDEC designator for Matte Tin (Sn)
	*	This package is Pb-free. The Pb-free JEDEC designator (e3) can be found on the outer packaging for this package.

Note: In the event the full Microchip part number cannot be marked on one line, it will be carried over to the next line, thus limiting the number of available characters for customer-specific information.

ATA6562/3

8-Lead 3 X 3 mm VDFN

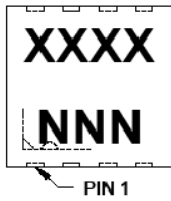

Example
ATA6562 Grade 0

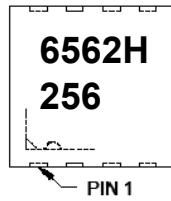

Example
ATA6562 Grade 1

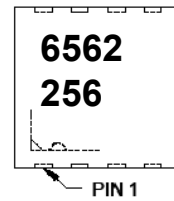

Example
ATA6563 Grade 0

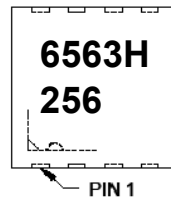

Example
ATA6563 Grade 1

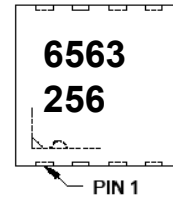

Legend:	XX...X	Customer-specific information
	Y	Year code (last digit of calendar year)
	YY	Year code (last 2 digits of calendar year)
	WW	Week code (week of January 1 is week '01')
	NNN	Alphanumeric traceability code
	(e3)	Pb-free JEDEC designator for Matte Tin (Sn)
	*	This package is Pb-free. The Pb-free JEDEC designator (e3) can be found on the outer packaging for this package.

Note: In the event the full Microchip part number cannot be marked on one line, it will be carried over to the next line, thus limiting the number of available characters for customer-specific information.

8-Lead Plastic Small Outline (SN) - Narrow, 3.90 mm (.150 In.) Body [SOIC]

Note: For the most current package drawings, please see the Microchip Packaging Specification located at <http://www.microchip.com/packaging>

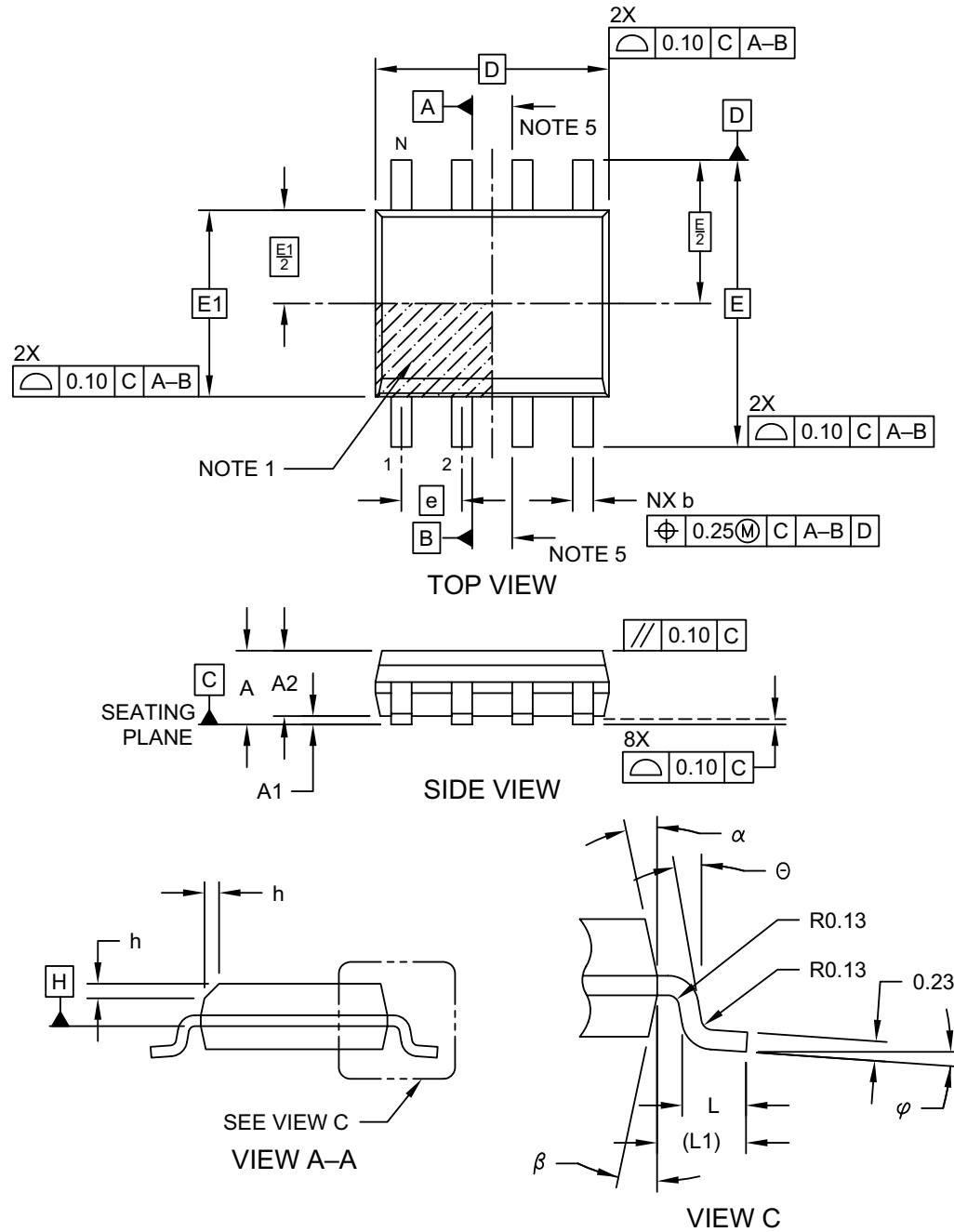

Microchip Technology Drawing No. C04-057-SN Rev F Sheet 1 of 2

ATA6562/3

8-Lead Plastic Small Outline (SN) - Narrow, 3.90 mm (.150 In.) Body [SOIC]

Note: For the most current package drawings, please see the Microchip Packaging Specification located at <http://www.microchip.com/packaging>

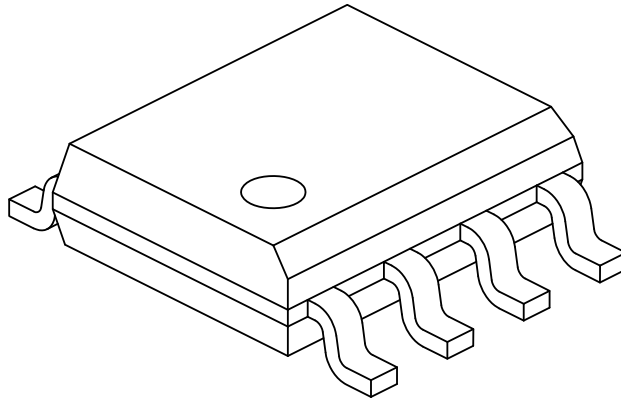

Dimension Limits	Units	MILLIMETERS		
		MIN	NOM	MAX
Number of Pins	N	8		
Pitch	e	1.27 BSC		
Overall Height	A	-	-	1.75
Molded Package Thickness	A2	1.25	-	-
Standoff §	A1	0.10	-	0.25
Overall Width	E	6.00 BSC		
Molded Package Width	E1	3.90 BSC		
Overall Length	D	4.90 BSC		
Chamfer (Optional)	h	0.25	-	0.50
Foot Length	L	0.40	-	1.27
Footprint	L1	1.04 REF		
Foot Angle	φ	0°	-	8°
Lead Thickness	c	0.17	-	0.25
Lead Width	b	0.31	-	0.51
Mold Draft Angle Top	α	5°	-	15°
Mold Draft Angle Bottom	β	5°	-	15°

Notes:

- Pin 1 visual index feature may vary, but must be located within the hatched area.
- § Significant Characteristic
- Dimensions D and E1 do not include mold flash or protrusions. Mold flash or protrusions shall not exceed 0.15mm per side.
- Dimensioning and tolerancing per ASME Y14.5M
BSC: Basic Dimension. Theoretically exact value shown without tolerances.
REF: Reference Dimension, usually without tolerance, for information purposes only.
- Datums A & B to be determined at Datum H.

Microchip Technology Drawing No. C04-057-SN Rev F Sheet 2 of 2

8-Lead Plastic Small Outline (SN) - Narrow, 3.90 mm (.150 In.) Body [SOIC]

Note: For the most current package drawings, please see the Microchip Packaging Specification located at <http://www.microchip.com/packaging>

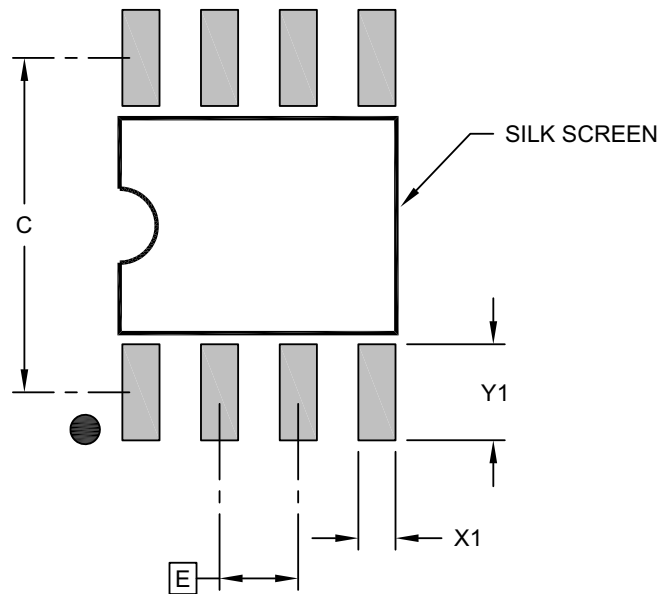

RECOMMENDED LAND PATTERN

Dimension Limits	Units	MILLIMETERS		
		MIN	NOM	MAX
Contact Pitch	E		1.27 BSC	
Contact Pad Spacing	C		5.40	
Contact Pad Width (X8)	X1			0.60
Contact Pad Length (X8)	Y1			1.55

Notes:

1. Dimensioning and tolerancing per ASME Y14.5M
BSC: Basic Dimension. Theoretically exact value shown without tolerances.

Microchip Technology Drawing C04-2057-SN Rev F

ATA6562/3

8-Lead Very Thin Plastic Dual Flat, No Lead Package (Q8B) - 3x3 mm Body [VDFN] With 2.40x1.60 mm Exposed Pad and Stepped Wettable Flanks

Note: For the most current package drawings, please see the Microchip Packaging Specification located at <http://www.microchip.com/packaging>

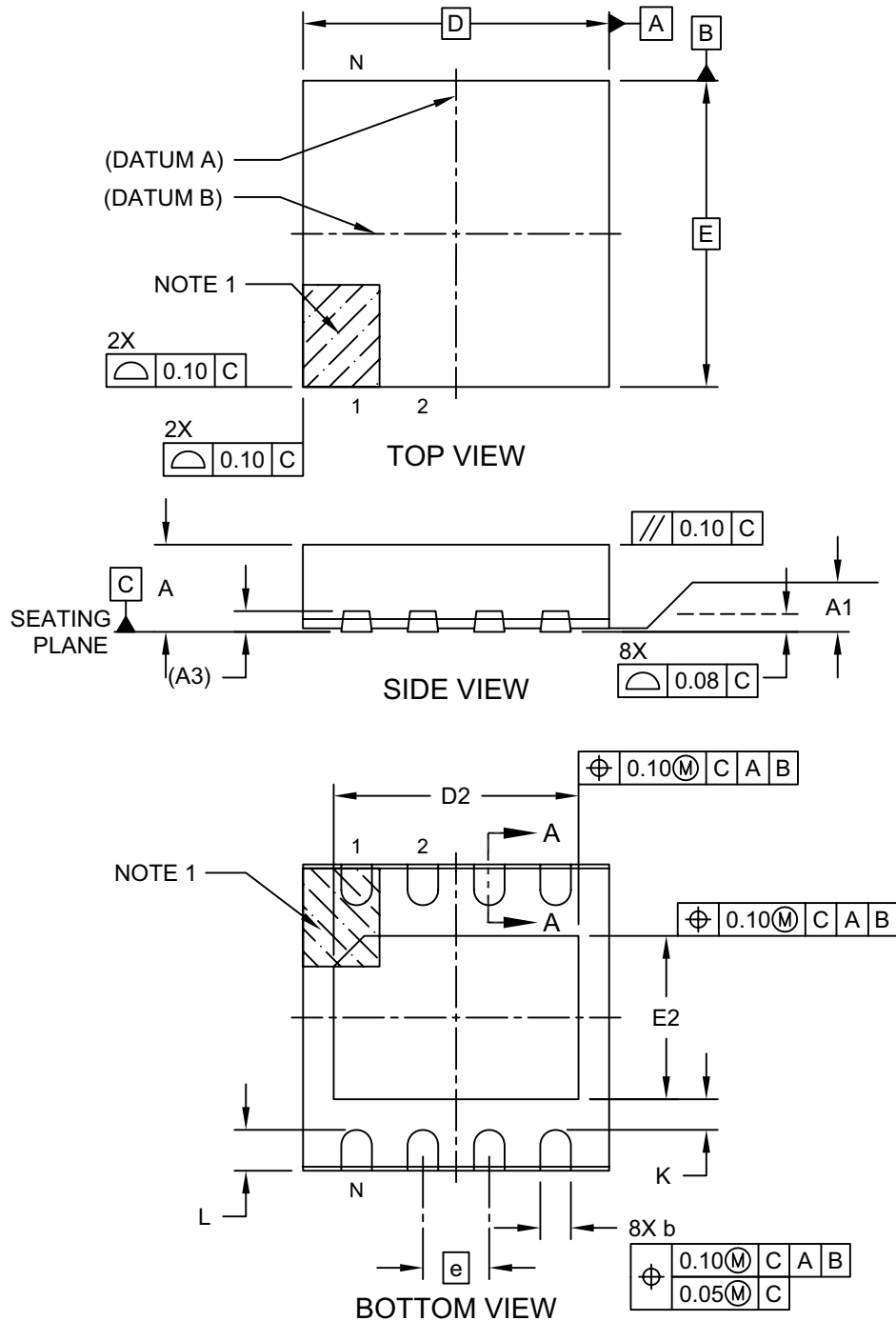

Microchip Technology Drawing C04-21358 Rev B Sheet 1 of 2

8-Lead Very Thin Plastic Dual Flat, No Lead Package (Q8B) - 3x3 mm Body [VDFN] With 2.40x1.60 mm Exposed Pad and Stepped Wettable Flanks

Note: For the most current package drawings, please see the Microchip Packaging Specification located at <http://www.microchip.com/packaging>

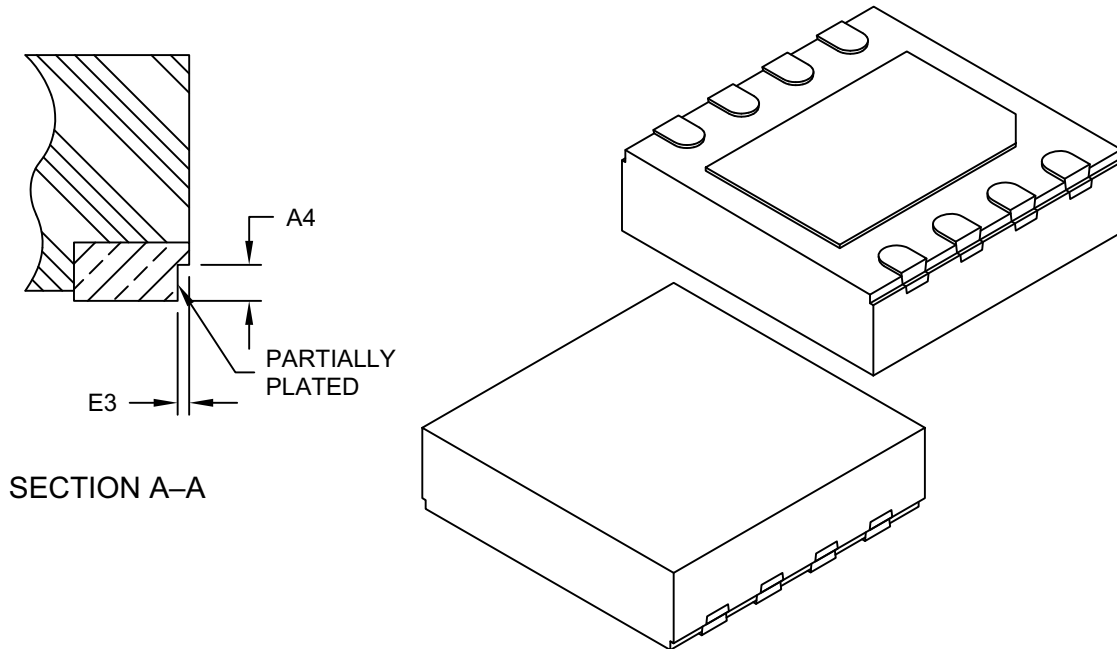

Dimension Limits	Units	MILLIMETERS		
		MIN	NOM	MAX
Number of Terminals	N	8		
Pitch	e	0.65 BSC		
Overall Height	A	0.80	0.85	0.90
Standoff	A1	0.00	0.03	0.05
Terminal Thickness	A3	0.203 REF		
Overall Length	D	3.00 BSC		
Exposed Pad Length	D2	2.30	2.40	2.50
Overall Width	E	3.00 BSC		
Exposed Pad Width	E2	1.50	1.60	1.70
Terminal Width	b	0.25	0.30	0.35
Terminal Length	L	0.35	0.40	0.45
Terminal-to-Exposed-Pad	K	0.20	-	-
Wettable Flank Step Cut Depth	A4	0.10	0.13	0.15
Wettable Flank Step Cut Width	E3	-	-	0.04

Notes:

- Pin 1 visual index feature may vary, but must be located within the hatched area.
- Package is saw singulated
- Dimensioning and tolerancing per ASME Y14.5M
 BSC: Basic Dimension. Theoretically exact value shown without tolerances.
 REF: Reference Dimension, usually without tolerance, for information purposes only.

Microchip Technology Drawing C04-21358 Rev B Sheet 2 of 2

8-Lead Very Thin Plastic Dual Flat, No Lead Package (Q8B) - 3x3 mm Body [VDFN] With 2.40x1.60 mm Exposed Pad and Stepped Wettable Flanks

Note: For the most current package drawings, please see the Microchip Packaging Specification located at <http://www.microchip.com/packaging>

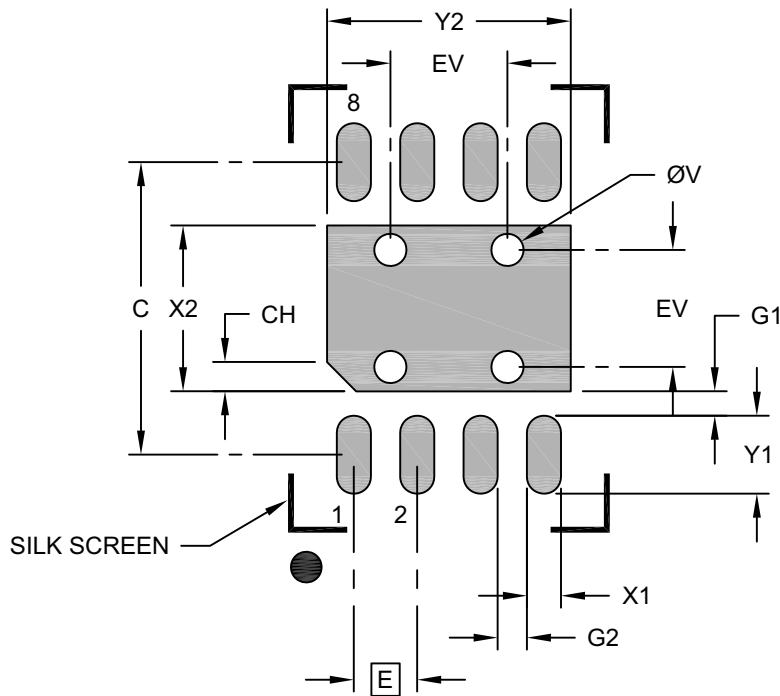

RECOMMENDED LAND PATTERN

Dimension Limits	Units	MILLIMETERS		
		MIN	NOM	MAX
Contact Pitch	E	0.65 BSC		
Optional Center Pad Width	X2			1.70
Optional Center Pad Length	Y2			2.50
Contact Pad Spacing	C		3.00	
Contact Pad Width (X8)	X1			0.35
Contact Pad Length (X8)	Y1			0.80
Contact Pad to Center Pad (X8)	G1	0.20		
Contact Pad to Contact Pad (X6)	G2	0.20		
Pin 1 Index Chamfer	CH	0.20		
Thermal Via Diameter	V		0.33	
Thermal Via Pitch	EV		1.20	

Notes:

1. Dimensioning and tolerancing per ASME Y14.5M
BSC: Basic Dimension. Theoretically exact value shown without tolerances.
2. For best soldering results, thermal vias, if used, should be filled or tented to avoid solder loss during reflow process

Microchip Technology Drawing C04-23358 Rev B

APPENDIX A: REVISION HISTORY

Revision D (June 2020)

The following is the list of modifications:

1. Updated parameter “Supply Current in Silent Mode” in [Table 2-1: Electrical Characteristics](#).
2. Added test conditions at several parameters in [Table 2-1: Electrical Characteristics](#).
3. Added parameter “Bus Differential Output Voltage” in Standby mode in [Table 2-1: Electrical Characteristics](#).
4. Updated [Package Marking Information](#)

Revision C (August 2019)

The following is the list of modifications:

1. Updated [TABLE 2-2: “Temperature Specifications”](#).
2. Added test conditions at several parameters in [TABLE 2-1: “Electrical Characteristics”](#).

Revision B (August 2017)

The following is the list of modifications:

1. Added new devices ATA6562-GBQW0 and ATA6563-GBQW0 and updated the related information across the document.
2. Updated [Features](#) section.
3. Updated [ATA6562/ATA6563 Family Members](#) section.
4. Updated [Table 2-2: Temperature Specifications](#).
5. Updated [Package Marking Information](#)
6. Updated [Product Identification System](#) section.
7. Various typographical edits.

Revision A (June 2017)

- Original Release of this Document.
- This document replaces Atmel - 9389C-11/16ATA6562/ATA6563

ATA6562/ATA6563

NOTES:

PRODUCT IDENTIFICATION SYSTEM

To order or obtain information, e.g., on pricing or delivery, refer to the factory or the listed sales office.

<u>PART NO.</u>	<u>XX</u>	<u>IXI⁽¹⁾</u>	<u>X</u>	<u>X</u>
Device	Package	Tape and Reel Option	Package directives classification	Temperature Range
Device:	ATA6562:		High-speed CAN Transceiver with Standby and Silent Mode CAN FD Ready	
	ATA6563:		High-speed CAN Transceiver with Standby Mode and VIO-pin CAN FD Ready	
Package:	GA	=	8-Lead SOIC	
	GB	=	8-Lead VDFN	
Tape and Reel Option:	Q	=	330 mm diameter Tape and Reel	
Package directives classification:	W	=	Package according to RoHS ⁽²⁾	
Temperature Range:	0	=	Temperature Grade 0 (-40°C to +150°C)	
	1	=	Temperature Grade 1 (-40°C to +125°C)	

Examples:	
a) ATA6562-GAQW0:	ATA6562, 8-Lead SOIC, Tape and Reel, Package according to RoHS, Temperature Grade 0
b) ATA6562-GAQW1:	ATA6562, 8-Lead SOIC, Tape and Reel, Package according to RoHS, Temperature Grade 1
c) ATA6562-GBQW0:	ATA6562, 8-Lead VDFN, Tape and Reel, Package according to RoHS, Temperature Grade 0
d) ATA6562-GBQW1:	ATA6562, 8-Lead VDFN, Tape and Reel, Package according to RoHS, Temperature Grade 1
e) ATA6563-GAQW0:	ATA6563, 8-Lead SOIC, Tape and Reel, Package according to RoHS, Temperature Grade 0
f) ATA6563-GAQW1:	ATA6563, 8-Lead SOIC, Tape and Reel, Package according to RoHS, Temperature Grade 1
f) ATA6563-GBQW0:	ATA6563, 8-Lead VDFN, Tape and Reel, Package according to RoHS, Temperature Grade 0
g) ATA6563-GBQW1:	ATA6563, 8-Lead VDFN, Tape and Reel, Package according to RoHS, Temperature Grade 1

Note 1: Tape and Reel identifier only appears in the catalog part number description. This identifier is used for ordering purposes and is not printed on the device package. Check with your Microchip Sales Office for package availability with the Tape and Reel option.

2: RoHS compliant, Maximum concentration value of 0.09% (900 ppm) for Bromine (Br) and Chlorine (Cl) and less than 0.15% (1500 ppm) total Bromine (Br) and Chlorine (Cl) in any homogeneous material. Maximum concentration value of 0.09% (900 ppm) for Antimony (Sb) in any homogeneous material.

ATA6562/3

NOTES:

Note the following details of the code protection feature on Microchip devices:

- Microchip products meet the specification contained in their particular Microchip Data Sheet.
- Microchip believes that its family of products is one of the most secure families of its kind on the market today, when used in the intended manner and under normal conditions.
- There are dishonest and possibly illegal methods used to breach the code protection feature. All of these methods, to our knowledge, require using the Microchip products in a manner outside the operating specifications contained in Microchip's Data Sheets. Most likely, the person doing so is engaged in theft of intellectual property.
- Microchip is willing to work with the customer who is concerned about the integrity of their code.
- Neither Microchip nor any other semiconductor manufacturer can guarantee the security of their code. Code protection does not mean that we are guaranteeing the product as “unbreakable.”

Code protection is constantly evolving. We at Microchip are committed to continuously improving the code protection features of our products. Attempts to break Microchip's code protection feature may be a violation of the Digital Millennium Copyright Act. If such acts allow unauthorized access to your software or other copyrighted work, you may have a right to sue for relief under that Act.

Information contained in this publication regarding device applications and the like is provided only for your convenience and may be superseded by updates. It is your responsibility to ensure that your application meets with your specifications. MICROCHIP MAKES NO REPRESENTATIONS OR WARRANTIES OF ANY KIND WHETHER EXPRESS OR IMPLIED, WRITTEN OR ORAL, STATUTORY OR OTHERWISE, RELATED TO THE INFORMATION, INCLUDING BUT NOT LIMITED TO ITS CONDITION, QUALITY, PERFORMANCE, MERCHANTABILITY OR FITNESS FOR PURPOSE. Microchip disclaims all liability arising from this information and its use. Use of Microchip devices in life support and/or safety applications is entirely at the buyer's risk, and the buyer agrees to defend, indemnify and hold harmless Microchip from any and all damages, claims, suits, or expenses resulting from such use. No licenses are conveyed, implicitly or otherwise, under any Microchip intellectual property rights unless otherwise stated.

Trademarks

The Microchip name and logo, the Microchip logo, Adaptec, AnyRate, AVR, AVR logo, AVR Freaks, BesTime, BitCloud, chipKIT, chipKIT logo, CryptoMemory, CryptoRF, dsPIC, FlashFlex, flexPWR, HELDO, IGLOO, JukeBlox, KeeLoq, Klear, LANCheck, LinkMD, maXStylus, maXTouch, MediaLB, megaAVR, Microsemi, Microsemi logo, MOST, MOST logo, MPLAB, OptoLyzer, PackeTime, PIC, picoPower, PICSTART, PIC32 logo, PolarFire, Prochip Designer, QTouch, SAM-BA, SenGenuity, SpyNIC, SST, SST Logo, SuperFlash, Symmetricom, SyncServer, Tachyon, TempTrackr, TimeSource, tinyAVR, UNI/O, Vectron, and XMEGA are registered trademarks of Microchip Technology Incorporated in the U.S.A. and other countries.

APT, ClockWorks, The Embedded Control Solutions Company, EtherSynch, FlashTec, Hyper Speed Control, HyperLight Load, IntelliMOS, Libero, motorBench, mTouch, Powermite 3, Precision Edge, ProASIC, ProASIC Plus, ProASIC Plus logo, Quiet-Wire, SmartFusion, SyncWorld, Temux, TimeCesium, TimeHub, TimePictra, TimeProvider, Vite, WinPath, and ZL are registered trademarks of Microchip Technology Incorporated in the U.S.A.

Adjacent Key Suppression, AKS, Analog-for-the-Digital Age, Any Capacitor, AnyIn, AnyOut, BlueSky, BodyCom, CodeGuard, CryptoAuthentication, CryptoAutomotive, CryptoCompanion, CryptoController, dsPICDEM, dsPICDEM.net, Dynamic Average Matching, DAM, ECAN, EtherGREEN, In-Circuit Serial Programming, ICSP, INICnet, Inter-Chip Connectivity, JitterBlocker, KlearNet, KlearNet logo, memBrain, Mindi, MiWi, MPASM, MPF, MPLAB Certified logo, MPLIB, MPLINK, MultiTRAK, NetDetach, Omniscient Code Generation, PICDEM, PICDEM.net, PICKit, PICtail, PowerSmart, PureSilicon, QMatrix, REAL ICE, Ripple Blocker, SAM-ICE, Serial Quad I/O, SMART-I.S., SQI, SuperSwitcher, SuperSwitcher II, Total Endurance, TSHARC, USBCheck, VariSense, ViewSpan, WiperLock, Wireless DNA, and ZENA are trademarks of Microchip Technology Incorporated in the U.S.A. and other countries.

SQTP is a service mark of Microchip Technology Incorporated in the U.S.A.

The Adaptec logo, Frequency on Demand, Silicon Storage Technology, and Symmcom are registered trademarks of Microchip Technology Inc. in other countries.

GestIC is a registered trademark of Microchip Technology Germany II GmbH & Co. KG, a subsidiary of Microchip Technology Inc., in other countries.

All other trademarks mentioned herein are property of their respective companies.

© 2020, Microchip Technology Incorporated, All Rights Reserved.

ISBN: 978-1-5224-6283-5

For information regarding Microchip's Quality Management Systems, please visit www.microchip.com/quality.



MICROCHIP

Worldwide Sales and Service

AMERICAS

Corporate Office
2355 West Chandler Blvd.
Chandler, AZ 85224-6199
Tel: 480-792-7200
Fax: 480-792-7277
Technical Support:
<http://www.microchip.com/support>
Web Address:
www.microchip.com

Atlanta

Duluth, GA
Tel: 678-957-9614
Fax: 678-957-1455

Austin, TX

Tel: 512-257-3370

Boston

Westborough, MA
Tel: 774-760-0087
Fax: 774-760-0088

Chicago

Itasca, IL
Tel: 630-285-0071
Fax: 630-285-0075

Dallas

Addison, TX
Tel: 972-818-7423
Fax: 972-818-2924

Detroit

Novi, MI
Tel: 248-848-4000

Houston, TX

Tel: 281-894-5983

Indianapolis

Noblesville, IN
Tel: 317-773-8323
Fax: 317-773-5453
Tel: 317-536-2380

Los Angeles

Mission Viejo, CA
Tel: 949-462-9523
Fax: 949-462-9608
Tel: 951-273-7800

Raleigh, NC

Tel: 919-844-7510

New York, NY

Tel: 631-435-6000

San Jose, CA

Tel: 408-735-9110
Tel: 408-436-4270

Canada - Toronto

Tel: 905-695-1980
Fax: 905-695-2078

ASIA/PACIFIC

Australia - Sydney
Tel: 61-2-9868-6733

China - Beijing
Tel: 86-10-8569-7000

China - Chengdu
Tel: 86-28-8665-5511

China - Chongqing
Tel: 86-23-8980-9588

China - Dongguan
Tel: 86-769-8702-9880

China - Guangzhou
Tel: 86-20-8755-8029

China - Hangzhou
Tel: 86-571-8792-8115

China - Hong Kong SAR
Tel: 852-2943-5100

China - Nanjing
Tel: 86-25-8473-2460

China - Qingdao
Tel: 86-532-8502-7355

China - Shanghai
Tel: 86-21-3326-8000

China - Shenyang
Tel: 86-24-2334-2829

China - Shenzhen
Tel: 86-755-8864-2200

China - Suzhou
Tel: 86-186-6233-1526

China - Wuhan
Tel: 86-27-5980-5300

China - Xian
Tel: 86-29-8833-7252

China - Xiamen
Tel: 86-592-2388138

China - Zhuhai
Tel: 86-756-3210040

ASIA/PACIFIC

India - Bangalore
Tel: 91-80-3090-4444

India - New Delhi
Tel: 91-11-4160-8631

India - Pune
Tel: 91-20-4121-0141

Japan - Osaka
Tel: 81-6-6152-7160

Japan - Tokyo
Tel: 81-3-6880-3770

Korea - Daegu
Tel: 82-53-744-4301

Korea - Seoul
Tel: 82-2-554-7200

Malaysia - Kuala Lumpur
Tel: 60-3-7651-7906

Malaysia - Penang
Tel: 60-4-227-8870

Philippines - Manila
Tel: 63-2-634-9065

Singapore
Tel: 65-6334-8870

Taiwan - Hsin Chu
Tel: 886-3-577-8366

Taiwan - Kaohsiung
Tel: 886-7-213-7830

Taiwan - Taipei
Tel: 886-2-2508-8600

Thailand - Bangkok
Tel: 66-2-694-1351

Vietnam - Ho Chi Minh
Tel: 84-28-5448-2100

EUROPE

Austria - Wels
Tel: 43-7242-2244-39
Fax: 43-7242-2244-393

Denmark - Copenhagen
Tel: 45-4485-5910
Fax: 45-4485-2829

Finland - Espoo
Tel: 358-9-4520-820

France - Paris
Tel: 33-1-69-53-63-20
Fax: 33-1-69-30-90-79

Germany - Garching
Tel: 49-8931-9700

Germany - Haan
Tel: 49-2129-3766400

Germany - Heilbronn
Tel: 49-7131-72400

Germany - Karlsruhe
Tel: 49-721-625370

Germany - Munich
Tel: 49-89-627-144-0
Fax: 49-89-627-144-44

Germany - Rosenheim
Tel: 49-8031-354-560

Israel - Ra'anana
Tel: 972-9-744-7705

Italy - Milan
Tel: 39-0331-742611
Fax: 39-0331-466781

Italy - Padova
Tel: 39-049-7625286

Netherlands - Drunen
Tel: 31-416-690399
Fax: 31-416-690340

Norway - Trondheim
Tel: 47-7288-4388

Poland - Warsaw
Tel: 48-22-3325737

Romania - Bucharest
Tel: 40-21-407-87-50

Spain - Madrid
Tel: 34-91-708-08-90
Fax: 34-91-708-08-91

Sweden - Gothenberg
Tel: 46-31-704-60-40

Sweden - Stockholm
Tel: 46-8-5090-4654

UK - Wokingham
Tel: 44-118-921-5800
Fax: 44-118-921-5820